

**NEWTON'S
LONDON
JOURNAL OF
ARTS AND
SCIENCES:...**

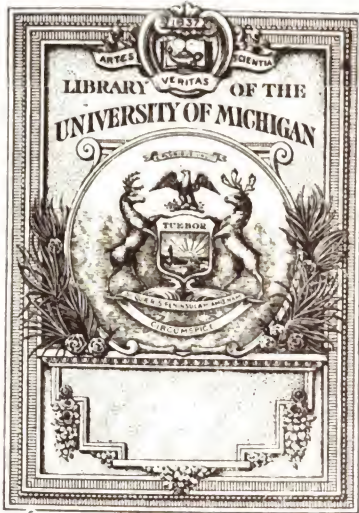



T
I
.NSG

S. Sutton Rawlinson.

THE
LONDON JOURNAL
OF
Arts, Sciences, and Manufactures,
AND
REPERTORY
OF
PATENT INVENTIONS.

CONDUCTED BY
MR. W. NEWTON,
OF THE OFFICE FOR PATENTS, CHANCERY LANE.

(Assisted by several Scientific Gentlemen.)

VOL. XXV.

(CONJOINED SERIES.)

LONDON:

PUBLISHED BY W. NEWTON, AT THE OFFICE FOR PATENTS, 66, CHANCERY LANE, AND TOWN HALL BUILDINGS, MANCHESTER; SHERWOOD, GILBERT, AND PIPER, PATERNOSTER ROW; SIMPKIN AND MARSHALL, STATIONERS' COURT; AND GALIGNANI'S LIBRARY, RUE VIVIERNE, PARIS.

1844.



**R. FOLKARD, PRINTER, DEVONSHIRE STREET,
QUEEN SQUARE.**

LIST OF PLATES IN VOL. XXV.

[CONJOINED SERIES.]

- I. Nasmyth's Machinery for Driving Piles and Stamping Metals; Brockedon's Apparatus for Making Pills, Lozenges, &c.; and Jackson's Improved Spindles and Flyers.
- II. Day's Apparatus for Loading Vessels; Booth's Improvements in Propelling; Hale's Rockets; and Holmes' Improvements in Furnaces.
- III. Newton's Improved Axle-boxes; Morewood and Rogers' Apparatus for Coating Metals; Parly's Improved Wheels; and Masterman's Refrigerator.
- IV. Detmold's Improvements in Manufacturing Iron; Walker's Improvements in Candles, Candlesticks, Snuffers, &c.; Lindley's Coffins; and Shepherd's Improved Valves for Steam-engines.
- V. Foulerton's Improvements in Steering Vessels; and Watson's Apparatus for Manufacturing Salts of Ammonia.
- VI. Nichol's Printing Presses; Walter's Improvements in Gloves; Hay's Signal Lights; and Schottlaender's Improvements in Depositing Metals.
- VII. Hardman's Machinery for Manufacturing Sugar; Haines' Improvements in Chains; and Thomas' Fastenings for Apparel, &c.
- VIII. Grimsley's Improvements in Roofs and other parts of Buildings; Connell's Candlewicks; and Fairbairn's Improvements in Propelling.
- IX. Lance's Apparatus for the Whale Fishery; Corcoran's Improved Mill-stones; Robson's Machinery for Raising Liquids; and Mills' Fastening for Gloves, &c.

- X. Hick's Improvements in Steam-Engines, Hydrometers, Coupling Gear, &c. ; Parkes' Improved Chains; and Walther's Improvements in Steam-engines.
- XI. Wood's Improvements in Increasing the Buoyancy of Vessels, &c. ; and Trail's Mode of Strengthening Sails.
- XII. Newton's Machinery for Making India-rubber Goods ; Wright and Wright's Improvements in Boots, Shoes, &c. ; Macdonough's Spinning Machinery ; Lambert's Improvements in Piano-fortes ; Du Bochet's ditto ; and Roose's Machinery for Manufacturing Tubes.
- XIII. Hardy's Machinery for Welding Tubes ; Wardroper's Improved Hooks and Eyes ; Studley's Mill ; and Butterworth's Improvements in Machinery for Preparing Fibrous Substances.
- XIV. Martin's Improvements in Slate Roofs, Tanks, and Pipes ; Troughton's Apparatus for Washing Ores ; and Hill's Improvements in Axles, Shafts, and Bars.
- XV. Davies' Improvements in Propelling Vessels ; Bostwick's Machine for Sewing ; Wolcott and Johnson's Improvements in Photography ; and Allaire's Apparatus for Cleansing Garments.
- XVI. Keely and Alliot's Machinery for Drying and Stretching Fabrics ; Straker's Windlass ; Hazard's Improved Shower-bath ; and Mollett and Bridgman's Machinery for Treating Fatty Matters.
- XVII. Newton's Apparatus for Manufacturing Cyanogen ; Cobbold's Improvements in Treating Peat ; and Denton's Machinery for Making Drain Tiles, &c.
- XVIII. Grant's Apparatus for Ventilating Apartments ; and Bremner's Improvements in Constructing Buildings in Water.
-

THE
LONDON JOURNAL
AND
REPERTORY
OF
Arts, Sciences, and Manufactures.

CONJOINED SERIES.

No. CLII.

RECENT PATENTS.

To JAMES NASMYTH, of Patricroft, near Manchester, in the county of Lancaster, engineer, for certain improvements in machinery or apparatus for driving piles; part or parts of which improvements are applicable also to forging and stamping metals and other substances.—[Sealed 24th July, 1843.]

THESE improvements in machinery or apparatus for driving piles consist, Firstly, in a certain arrangement of apparatus, by means of which the elastic force of steam is caused to lift up or raise a block of iron or other suitable material, and allow the same to fall down again on the head of a pile, for the purpose of driving it into the ground; this lifting and falling motion of the block of iron or ram (as it is generally called) being obtained without the employment of any wheel-work or rotatory motion whatsoever, so far as the motion of the said ram or block is concerned. Secondly, in the means by which the weight of the block or ram, together with the weight of the apparatus thereunto attached, is made to assist, by its continual pressure, in predisposing the pile to sink

into the ground; thereby causing the blow from the ram to be very much more effective in driving the pile. Thirdly, in the means by which a considerable additional energy is given to the descent of the ram, by the elasticity of compressed steam or air, super-added to the force of gravity, (which is the chief blow-giving power to the ram). Fourthly, in certain means whereby the valve, which admits the steam to lift the ram or block, is caused to be itself opened, by means of the direct action of the elastic force of the said steam, and which is hereinafter more particularly described; as also certain parts of the apparatus by which the said valve is enabled to pass through its required motions, so as to make this pile-driving machine self-acting, in so far as the production of a series of blows is concerned; these parts of the apparatus being also applicable to certain machinery employed in forging and stamping metals and other substances.

In Plate I., fig. 1, exhibits the general arrangement of the apparatus, as employed in driving piles. It consists of a steam-cylinder *A*, sliding between two upright wooden guides *a*¹, *a*¹. This steam-cylinder *A*, is mounted on a suitable platform *b*, *b*, *b*, either resting on the ground, or on a barge or boat, (when driving piles out in a river or harbour,) as the case may require, and is supplied with high-pressure steam from a boiler *B*, by means of a zig-zag or other suitably-jointed pipe *P*, *P*, together with a windlass and hoisting gear, for the purpose of raising the cylinder *A*, and its ram, tube, and socket, *R*, *D*, *E*, on to the top of the pile; the windlass-chain being kept slack during the driving of the pile, so that the weight of the cylinder *A*, guide-tube *D*, and socket-tube *E*, may rest entirely on the pile; the pall *G*, *G*, preventing it from slipping down too far.

Fig. 2, is a section, and fig. 3, a front view, on an enlarged scale, of the steam-cylinder *A*, in which it will be seen there is a piston *c*, and piston-rod *D**; which latter passes out at the bottom of the cylinder, and is finally attached to the block or ram *R*, by a certain means of union, more particularly described hereafter. The steam-cylinder *A*, is fixed on the top of an iron case or tube *D*, which also serves as a guide to the ram *R*; this wrought-iron case or tube is

in like manner fixed on the top of another smaller tube ϵ , which is made of such a size as to fit easily over the body of the pile to be driven; the entire weight of the cylinder λ , ram κ , tube ν , and socket-tube ϵ , being supported by the catch-palls σ, σ , the points of which rest, for that purpose, in a rough notch cut in the pile. Thus it is that the pile has a predisposition to sink into the ground by the effect of the superincumbent weight of the above-named parts of the apparatus.

In order to describe the action of the apparatus, we shall suppose the windlass-chain to be left slack, and the steam to enter freely by the steam-passage x, x , and so press upon the under side of the piston c ; in this position the steam, acting with all its elastic force on the under side of the said piston, raises or lifts up the ram κ , (to which, as before said, it is attached,) by the piston-rod ν^* , and continues to force the piston upwards, until the edge of the ram κ , comes in contact with the pall σ , which it raises from its horizontal position to that seen in the section, fig. 2; in doing which, it will be evident, that as the pall σ , is attached to the valve-rod τ , (which has an elastic junction at τ^1 , for the purpose of removing the jerk from the slide-valve,) the edge of the ram forcing up the pall σ , at the same time, slides the valve κ , up into the situation seen at fig. 2. By this means, the shoulder s , at the lower end of the valve-rod, is lifted above the point of the trigger or catch n ; which, by means of the spring behind at n , causes the point of the trigger to retain the valve-rod and valve in the position in which the ram has placed it, by its coming in contact with the pall σ , as before described. Now, it will be seen, on inspecting fig. 2, that the consequence of the valve being placed in this position, is not only to let the point of the trigger n , pass under the shoulder s , but also to cut off the communication between the boiler and the under side of the piston, by reason of the valve-face sliding over the opening x ; and further, as a consequence of the motion of the valve, there is now a free passage opened for the steam to escape from under the piston into the open air, by the passage z ; the immediate result of this is the fall of the piston c , and ram κ , which descends,

with all due energy, on the top of the pile, thereby assuming the position shewn by dots in fig. 3. The instant consequence of this fall is a blow on the head of the pile, which is driven down in due proportion to the energy of the blow, together with, and assisted by, the predisposing action of the superincumbent weight, as before named. Immediately after the blow, the catch-palls *g, g*, resume their original position in the notches, as in fig. 2. Another effect of the blow or concussion is the starting down of the end of the latch *L*, which is placed in or on a convenient part of the body of the ram *R*, and being retained, before the blow was given, in the elevated position, by means of a small spring-knob resting on the pin *w*, the concussion of the blow jerks the end *L*, down into the position represented by dots; the result of which is, that the other extremity *m*, of the said latch is made to protrude, (by its segmental motion around the centre pin *q*,) and, in so protruding, the point *m*, comes in contact with the bar *v*, which it presses back from the position seen in fig. 2; the result of this is the withdrawing of the point of the trigger *N*, from under the shoulder *s*, or lip on the valve-rod. The instant this is done, the steam presses on the top of the small piston *I*, which is placed in the cylinder *Y*, on the upper end of the valve-rod *T*, and forces the valve *K*, down into its former position; thus instantly re-admitting the steam from the boiler through the passage *x*, which conducts it under the piston *c*: this is immediately followed by the rise of the ram, as before. The rise of the ram causes the point *m*, of the latch *L*, to come in contact with the side of the tube or case *D*, at *D*¹, which causes it to be replaced on the retaining knob *w*, and so made ready for the next concussion to jerk it off, and unlock the trigger *s*, as before described.

The patentee desires it to be understood, that the employment of the trigger, as a means of retaining the valve in that position which permits of a free escape of the steam from under the piston, in opposition to the constant opening tendency which is given to the valve by the small steam-cylinder and piston *I*, and *Y*, is a most important feature in the means of rendering this pile-driving machine self-acting; together with the system by which the concussion (arising from the

blow given by the ram) is caused to unlock the said trigger, by the transmission of the motion of the latch *L*, to that of the trigger *N*, either by the latch placed in the ram, or by a connection with the pall *G*, which transmits, in like manner, the effect of the blow to the trigger, and so jerks it out below the lip or shoulder *S*, as may be found most convenient, either by the pall *G*, and its connecting-rod *Q*, or by the latch *L*, as before described.

There are several modes of transmitting the effects of the concussion to the trigger, which it would be here superfluous to name. The patentee prefers the latch arrangement, as exhibited in the drawings, and as already described. At figs. 4, and 5, the above trigger and latch-apparatus is shewn, as an improvement, applied to a machine for forging, cutting, and stamping iron and other materials, (as exhibited and described in the specification of a patent granted to the present patentee, and dated 9th June, 1842,*) for the same object as in the pile-driving apparatus; namely, as a means of deriving the self-acting motion from the concussion arising from the blow of the ram or block *R*, whether it be employed to drive piles, or to forge, cut, and stamp iron and other materials. In the case of its application to such a machine as that shewn at fig. 4, for forging iron, a bar *P*, *P*, is employed, so that the segmental protrusion of the point *M*, of the latch *L*, may unlock the trigger *N*, on the ram giving a blow to a mass of iron of any thickness, within the range of the fall of the ram. This is attained in the pile-driving machine, as required, by the length of the part or bar marked *V*, in fig. 2, by means of the parallel apparatus *P*, *P*.

The patentee directs particular attention to the means by which the steam is caused to open the valve; namely, the placing or fixing a small piston *I*, moving in a cylinder *V*, supplied with steam through the small pipe *f*; on the upper side of which piston *I*, the steam is made to press, when the ram raises the pall *O*, into the position seen at fig. 2; in doing which, the top of the piston *I*, comes in contact with the tail of the small steam-valve *V*, and lifts it up off its seat,

* For specification of this patent see Vol. XXII., p. 183.

thus admitting the steam to press upon the piston *1*; so that the instant the trigger is jerked out under the shoulder *s*, or from off the shoulder *s*, as at fig. 4, the force of this steam, above the piston *1*, instantly comes into action, and forcing down the valve, opens a free passage for the entrance of the steam under the piston *c*, as before described. The descent of the piston *1*, permits the valve *v*, to close, and at the same time, the steam which had been admitted is allowed to escape at the pipe *j*, simply by the piston *1*, passing it. Thus the piston *1*, acts as a valve, as well as a piston, and is, in that respect, self-acting. It will be observed, that the upward motion of the pall *o*, is not materially impeded by the pressure of the steam on the piston *1*, as no steam is admitted into the cylinder *Y*, until at the very last part of the motion, when the piston *1*, begins to come in contact with the tail of the small valve *v*.

Another feature in this invention, is the means by which an increased energy is given to the descent of the ram *R*; namely, by having the top or upper part of the cylinder *A*, made perfectly steam and air-tight, while a row of openings or holes is made in the upper part of the cylinder *A*, at *c, c*, which is equally applicable to all the above-named arrangements. The action of this arrangement is as follows:—The piston *c*, in its rapid ascent towards the top of the cylinder would, but for those holes *c, c*, accumulate a counter pressure above the piston, by reason of there being no egress for the confined air or steam. These holes prevent this, by permitting the otherwise confined air or steam to escape, until the piston has passed them; then it is that the remaining portion of steam or air is rapidly compressed, and gives a perfect elastic resistance, which defines the length of the upward stroke. On the instant of the piston passing above the holes, the steam which lifted the piston is partially allowed to escape, while, at the same instant, the elastic action of the compressed air or steam above the piston rebounds, and gives it, at that important moment, a most energetic commencement of the return or downward stroke; which materially enhances the effect and force of the blow, and is an important means of giving increased energy and rapidity

to the action of the ram, either as applied to the pile-driving apparatus, or to machinery employed in forging, cutting, and stamping iron and other material. The connection of the piston-rod and ram is made by two "cotters" or bolts, which are driven across the ram on each side of the piston-rod, as seen at H, H, figs. 2, 3, 4, and 5; these bolts are so driven across the ram, over and against the upper side of a ring of metal *h, h*, as to confine the elastic materials in the well at *w*, and also to resist the jerk of the action of the steam, without the use or requirement of any screws or other means.—
[Inrolled in the Petty Bag Office, January, 1844.]

Specification drawn by Messrs. Newton and Son.

To ROBERT RAYNSFORD JACKSON, of Blackburn, in the county of Lancaster, cotton-spinner, for certain improvements in the machinery or apparatus to be used in the preparation of cotton and other fibrous substances for spinning.—[Sealed 4th November, 1843.]

THESE improvements apply, firstly, to the carding-engine; and, secondly, to the spindle and flyer of the roving and slubbing machines used in the "preparation" processes. The improvement in carding-engines consists in the application and use of a peculiar construction of roller or cylinder, for the purpose of stripping or clearing the main-cylinder of the engine. This cylinder or roller is to be furnished with a narrow fillet or strip of cards, which is to be wound once round the roller, from end to end, and thus form a spiral rib or fillet of card, which is intended to act against the main-cylinder continuously, as they revolve together in contact, and thus to strip or clear all parts of the main-cylinder equally and continuously, from side to side, instead of being applied at intervals, as is commonly the case. Instead of fillets of cards, fine brushes may be used, if preferred. For a main carding-cylinder of three feet diameter, this spiral clearer should be about eight inches diameter, and it must

always be so proportioned and geared (speeded) as to clear the main cylinder effectually; that is, to act upon every part of its periphery in any given or required time. This clearing-roller may be applied in contact with the main carding-cylinder in any convenient situation below the doffing-cylinder, and may receive its motion by means of suitable gearing from any desirable driving part of the carding-engine.

The improvements in roving and slubbing-machines or frames apply, firstly, to a peculiar construction and arrangement of such machines, in which the spindles are shortened, and the flyers are separated therefrom, having a bevilled wheel or other gearing attached to each of the flyers, for the purpose of giving them a rotary motion distinct from, and independent of, the rotary motion of the bobbin; the particular objects of which arrangement have been, to prevent the vibration of the spindles, and to afford a greater facility for doffing or dismounting the bobbins when full of roving or slubbing. Although this construction or arrangement of the roving and slubbing-frame (which the patentee considers of importance in this part of the preparation processes) has been previously known, it is stated not to have been heretofore efficiently practised.

The figures in Plate I., represent such detached parts of the roving and slubbing-machines as will be sufficient to illustrate the nature of this part of the improvements. Fig. 1, is a front elevation of one of the spindles and flyers, &c., of a roving or slubbing-machine: *a, a*, is the spindle, which is to be stationary, and bolted or fastened to the step or foot-rail *b, b*; *c, c*, is the bobbin mounted on the spindle by means of the washer *d*, which is fast to the bevilled pinion *e*, gearing with the bevilled wheel *f*, fixed on the driving-shaft *g*, which extends throughout the machine, and drives each bobbin in a similar manner; *h, h*, is a common presser-flyer, which is suspended in the rails *i*, and *j*, by being fast to, or of one piece with, the tube or guide *k*; the whole being caused to revolve, and wind the roving or slubbing *l*, on to the bobbin, by means of the bevilled gearing *m, m*, and driving-shaft *n, n*, or by any other convenient arrangement. This description of

roving or slubbing-frame may be used either in a horizontal or perpendicular position. The flyer is provided with a metallic ring *o, o*, which confines the ends of the flyer arms, and thus, by preventing their expansion, when revolving at high velocities, enables the machine to be driven so much the more quickly, without any corresponding ill effect; and which improvement may also be applied to ordinary roving and slubbing-flyers. A small spherical disc or washer *p*, shewn in the sectional view, fig. 2, is provided above the flyer, for the purpose of preventing the oil, supplied to the flyer, from falling on to the bobbin, or running down the flyer arms below. By this means the oil is caused to flow along the rail *j*, where it may be collected.

It will be seen that the whole of the lower part of the machine, that is, the bobbins, spindles, and their rails and gearing, must be caused to rise and fall, which may be effected by any ordinary and well-known copping motion: the lowest position is represented by the dotted lines in fig. 1. When the bobbins become full of roving or slubbing, and it is required to doff or dismount them, it is only necessary to lower the foot-rail, which will withdraw the spindles from the bobbins; the bobbins may then be removed by hand, and empty ones supplied, and the spindles and rail replaced. Figs. 3, and 4, represent further modifications of the roving and slubbing-flyer, designed as an improvement on the common or well-known presser-flyer. It will be seen, that the difference in fig. 3, is simply making the presser *a*, as a slight hanging-bar, attached alongside the leg of the flyer; the pressure being effected by the spring *b*, which may be either above or below the swivel-joint *c*. By this modification of the presser-flyer, the ordinary spur-presser is dispensed with, and the "piecing" more readily performed, as well as also dispensing with the objectionable coil of the roving or slubbing usually made round the spur or presser, which frequently distorts and drags the roving or slubbing. Fig. 4, is a modification of the above, whereby the peculiar form and application of the spring *b*, and the pressure of the loose leg *a*, will be very much, if not quite, equalized, throughout the entire diameter, during the

formation of the bobbin. By attaching a small tube to the loose leg *a*, the fixed tube may be dispensed with from the point of the swivel-joint.—[*Inrolled in the Petty Bag Office, May, 1844.*]

Specification drawn by Messrs. Newton and Son.

To GEORGE HOLMES, of Stroudwater, in the county of Gloucester, engineer, for certain improvements in furnaces or fireplaces.—[Sealed 9th November, 1843.]

THIS invention consists in a novel or improved mode of admitting air to the flues of furnaces or fireplaces, for the purpose of promoting the combustion of smoke; and in the means of regulating the supply of air in proportion to the quantity of smoke that is evolved from the fuel. The means employed by the patentee to effect this object is shewn in Plate II., and consists in placing an air-chamber or passage in the ash-pit, beneath the grate-bars, and furnishing it with doors or valves, which are capable of being opened at pleasure. The mode preferred is, connecting the valves of the air-passage in any convenient manner to the fire-door, so that when the latter is opened, for the purpose of charging the fire with fresh fuel, the doors or valves of the air-chamber, in the ash-pit, are also opened, and a large volume of air thereby admitted to the flue of the furnace; and an apparatus is connected with the doors or valves of the air-chamber for the purpose of preventing them from closing immediately that the fire-door is shut. By means of this apparatus a large quantity of air is admitted to the flue, through or behind the bridge, just at the time that the fresh fuel is thrown on, and a great quantity of smoke is evolved therefrom; but, as the quantity of smoke diminishes, the supply of air is diminished by the gradual closing of the valves or doors, until the said doors are closed entirely.

Fig. 1, represents a longitudinal vertical section of a boiler and furnace, with the improvements applied thereto; and fig. 2, is a horizontal section of the same, taken in the line 1, 2, of the previous figure. *a*, is the furnace; *b*, *b*,

the flue ; *c*, is the ash-pit ; and *d*, the air-chamber, which supplies the flues with air by means of an aperture *e*, made in the bridge. The air-chamber is closed in front by means of doors or valves *f, f*, which are hinged to the sides of the chamber, and are opened and closed by the arms or rods *g, g*, which are jointed to the sliding-frame *h, h*. This frame *h*, carries a long rod or arm *i*, the outer end of which is jointed to a double arm or lever *j*, mounted on the lower end of the vertical shaft *k*. The opposite end of the double arm or lever *j*, is jointed to a rod *n*, the other end of which bears or acts against a strong helical spring *o*, placed in a box set in the brickwork. On the upper end of the vertical shaft *k*, an arm *l*, is mounted, and the outer end thereof is furnished with a segmental slot (see fig. 2), in which a pin or stud, at the end of the connecting rod *m*, works, and thereby connects the arm *l*, to the fire-door.

On the fire-door being opened, the arm *l*, is forced back ; this movement causes the vertical shaft *k*, to turn round, and draw the long rod *i*, forward, and thereby open the doors or valves *f, f*, of the air-chamber, to admit the air into the flue ; when the fire-door is closed again, the pin or stud which connects the rod *m*, of the fire-door, to the arm or lever *l*, slides along the segmental slot, formed at the end of the lever, and, by means of an apparatus hereafter described, allows these parts to come back slowly into their original position, and thereby gradually and slowly close the doors or valves of the air-chamber.

The apparatus for gradually closing the doors or valves of the air-chamber, after the fire-door has been opened, and the fuel supplied to the fire, is shewn detached, and on an enlarged scale, at figs. 3, and 4. Fig. 3, is a plan view of the apparatus, with the case in section, and fig. 4, is a view with the side casing removed, to shew the interior. The working parts of the apparatus are enclosed in a box or casing *p, p*, which is set in the brickwork ; *k, k*, is the vertical shaft before mentioned, which carries at its lower end the double arm or vibrating lever *j, j*, one end of which is connected to the long rod *i*, fig. 2, and the other end to the rod *n*, figs. 2, and 4, which acts against the spring *o*, as

before described. The respective parts in all the figures are shewn in the position they would occupy when the fire-door is shut, and the doors or valves of the air-chamber are also closed; but when the fire-door and air-chamber valves are open, the several parts would assume the position represented by dots in figs. 2, and 4. It will be seen in fig. 4, that a lever g , is connected to the arm n , by a joint, and is made to vibrate backwards and forwards on a moveable pin or axle z , at the outer end of an elbow lever v , as the said arm n , is pushed inwards by the lever j . The lower end of the lever g , carries a sector-rack, which is occasionally put in gear with the small pinion r ; on the same shaft as the pinion r , an escapement-wheel s , is mounted, the proper and regular rotation of which is regulated by the escapement-stops t, t , on the vertical shaft t^* . When the fire-door is closed, the sector-rack at the lower end of the lever g , is out of gear with the pinion; but when the door is opened, it forces back the rod or arm n , as already stated, and a stud or stop u , on the under side of the arm n , is brought into contact with the upper end of the lever v , which is mounted on a fixed centre at 1, and carries at its outer end 2, the vibrating lever g , before mentioned. By the stud or stop u , coming into contact with the upper end of the lever v , the lower end 2, is forced down, and the lever g , (which has, by means of the forward motion of the arm n , been brought into the position shewn by dots,) is depressed, so as to bring the teeth of the rack into gear with those of the pinion r ; then the spring o , which has been collapsed by the advance of the rod n , will begin to exert its force, and drive the said rod back again, and with it the lever g , and through the intervention of the sector-rack, will cause the pinion r , and escapement-wheel s , to revolve. The escapement-stops t, t , are mounted on the upper and lower ends of the vertical shaft t^* , and immediately below the lower stop, and on the same shaft, a horizontal sector-rack w , is mounted. This rack gears into a pinion x , on the axle of which is fixed a small toothed wheel y , which drives a pinion z , mounted on the axle of the fly-wheel Λ . From the foregoing description it will be understood, that the spring o , acts upon and drives

all this gearing, and that the speed thereof is regulated by the escapement, which retards its motion, and prevents the force of the spring from expending itself too suddenly; and by this means the valves or doors of the air-chamber are gradually closed, as before mentioned.

The patentee observes, that many alterations may be made in the arrangement and construction of the various parts of the apparatus, without departing from the principle of the invention; for instance, instead of the spring *o*, a weight may be raised by the action of opening the doors or valves of the air-chamber or passage, and allowed to fall slowly, and thus permit the said doors or valves to return gradually to their closed position.

The patentee claims the application to furnaces or fire-places, of an air-chamber or passage provided with doors or valves; such doors or valves being so arranged as to be capable of being opened at pleasure, either in connection with the fire-door or otherwise, and of returning slowly to their closed position by a retarded action of springs or weights.—*[Inrolled in the Petty Bag Office, May, 1844.]*

Specification drawn by Messrs. Newton and Son.

To WILLIAM BROCKEDON, of Devonshire-street, Queen-square, in the county of Middlesex, gent., for improvements in the manufacture of pills and medicated lozenges, and in preparing or treating black-lead. — [Scaled 8th December, 1843.]

IN the ordinary mode of making pills and medicated lozenges, the materials are mixed with a liquid containing gum or other adhesive matter, and formed into a stiff paste, which is divided into suitably-shaped portions, and allowed to dry; but it has been found, in some cases, that the gum or other adhesive matter interferes with and prevents the anticipated effect of the other materials. In order to obviate this result, the patentee takes the proper materials, in the state of powder, and solidifies them by pressure between

dies; thereby dispensing with the gum or other adhesive matter.

In Plate I., fig. 1, is a transverse section of the dies used for making pills. The lower die is composed of two parts *a*, *b*, and has a recess in it, in which the upper die *c*, works; the materials to be formed into pills are placed in the recess in the lower die, and the upper die is forced down upon them by means of a fly-press, or other suitable mode of applying pressure; the upper die and the part *a*, of the lower die are then raised, and the pill removed. For making lozenges, similar dies are employed, being suitably modified to produce the required shapes.

The successive quantities of materials operated on by the dies should be, as nearly as possible, of the same weight; and, to prevent the trouble of weighing, the patentee has invented a measuring instrument, which, on being pressed down into the prepared powder, will take up at each time a regulated quantity thereof. Figs. 2, and 3, exhibit partial sections of the instrument in two different positions. *d*, is a handle, fixed in the tube *e*, by a set-screw *f*; in this tube another tube *g*, closed at its lower end, slides freely, being connected by a screw, passed through a slot in the tube *e*, to another tube *h*, on the outside of the tube *e*; the extent of the movement of the tubes *g*, *h*, and the consequent amount of powder taken up by the tube *e*, depends upon the length of the slot, and the position of the handle in the tube *e*. When using this instrument, the tube *h*, is held in the hand; then, by depressing the handle *d*, the lower end of the tube *e*, is caused to protrude to the extent shewn in fig. 2, and is filled by pressing it into the powder; its contents are now discharged into the lower die, fig. 1, by raising the handle into the position shewn in fig. 3.

The second part of this invention consists in subjecting black-lead powder to pressure between dies, in order to form it into a solid mass or block.

Fig. 4, is a vertical section of the apparatus used for solidifying black-lead powder; and fig. 5, is a plan view of the lower die. The face of the lower die is partly cut away or recessed, leaving the parts *i*, *j*, projecting, and in the re-

cesses the wedges *k, l*, are inserted, forming, with the parts *j*, a hollow parallelepipedon *m*, into which the black-lead powder is put. Over the lower die a cover or receiver *n*, is placed; this cover rests upon the ledge *o*, and has a stuffing-box *p*, through which the plunger or upper die *q*, passes; the correct position of the plunger being insured by the entrance of the head of the small screw *r*, into the groove *s*, in the side of the lower die. The interior of the cover *n*, is first exhausted of air, by connecting a pipe from an air-pump with the nozzle *t*; and the plunger is then brought down with sufficient force to solidify the black-lead powder; the cover *n*, and plunger *q*, are now raised, the wedges *k, l*, driven out, and the newly-formed block of black-lead removed from the lower die; the ends of the parts *j*, having a slight degree of inclination, to facilitate its removal.

The patentee claims, Firstly,—the mode of manufacturing pills and medicated lozenges, by causing the proper materials, when in a state of granulation, dust, or powder, to be made into form and solidified in dies. And Secondly,—the mode of preparing or treating black-lead, when in a state of granulation, dust, or powder, by pressure in dies, so as to solidify the same.—[*Inrolled in the Inrolment Office, June, 1844.*]

To WILLIAM HALE, of Woolwich, in the county of Kent, engineer, for improvements in rockets.—[Sealed 11th January, 1844.]

THE chief part of this invention consists in dispensing with the stick now used for directing the course of the rocket, or the wings or projections which have been proposed to be substituted for it.

In Plate II., fig. 1, is a section of a rocket, which is caused to move with a considerable degree of correctness, without tumbling over in its flight, by having a weight at its lower end, through which a hole is bored in the line of the rocket's axis. *a*, is the metal case, which the patentee prefers to line with wood or other suitable material, to separate the charge of pyrotechnic matter *b*, from the metal; *c*, is a

hollow space left in the charge ; *d*, a cast-iron weight ; and *e*, the cast-iron head of the rocket, which is hollow, and may be filled with wood, or suitably formed for a shell, as seen in fig. 2.

Fig. 2, represents, in section, a rocket, which rotates during its flight, and thus allows of the force which drives it onward to move it more certainly ; as any bias which a rocket may have, consequent on a difference of weight in particular parts, or irregularity of form, will be counter-balanced by its rotating when thrown into the air. The rotation of the rocket is caused by the ignited matter rushing through the oblique openings *f*, which are made tangential to the circle formed by the cavity in the centre of the rocket. Fig. 3, exhibits another rocket, in which the openings *f*, are formed in the head *e*.

Fig. 4, shews a rocket in which the charge burns in two opposite directions. It has a shell *g*, at each end, with openings *h, h*, leading into them, to ignite the bursting powder ; the two parts of the charge *b*, are simultaneously consumed, and the ignited products rush into the chamber *i*, and thence through the openings *f* ; by which means a continuous rotary motion will be given to the rocket while it is being propelled. Fig. 5, is a section of another rocket, in which the two parts of the charge burn simultaneously, and the ignited products rush out through the openings *f* ; but the chamber *i*, is differently formed to that in the preceding figure, and there is only one shell *g*, at the front end of the rocket.

These rockets may be lighted by a quick-match, introduced into the spaces *c*, as represented by the dotted lines *j* ; and they may be fired or discharged from a trough or tube, in the ordinary manner.

The claims made by the patentee are, Firstly,—the application of a hollow or bored weight *d*, to the end of a rocket, as herein described. Secondly,—the formation of openings in rockets for the exit of the ignited matter, in such a manner as to cause them to rotate, as herein described. Thirdly,—forming double rockets, so that the pyrotechnic matter contained in them may be simultaneously consuming towards each end.—[Inrolled in the Inrolment Office, July, 1844.]

To HENRY AUSTIN, of 87, Hatton Garden, in the county of Middlesex, civil engineer, for a new method of glueing or cementing certain materials, for building and other purposes.—[Sealed 10th June, 1843.]

THE cement used by the patentee is made by mixing India-rubber with cold naphtha, in the proportion of eight ounces of India-rubber, cut into small pieces, to each gallon of naphtha, stirring it from time to time until the India-rubber is dissolved; then, to one part, by weight, of this mixture, two parts of lac are added, and the whole is thoroughly blended together by the application of heat, accompanied with occasional stirring. When greater elasticity is required, a larger proportion of the India-rubber solution is used; if greater hardness is necessary, a larger proportion of lac is employed; and where the India-rubber would be liable to injury from great exposure and pressure, a much less proportion is used, and it is sometimes dispensed with altogether: asphaltic, pitch, or resin, or other materials of that nature, may, in some instances, be substituted for the lac.

The materials for building purposes to which this cement is applied, are, slate, tiles, stone, glass, and metal plates. When being used, the cement is kept in a heated state in a dish or vessel, containing a narrow trough, termed a stamper, which slides up and down therein, between guides; the slate or other material is brought to heat of 150° Fahr., and placed upon the dish, and the stamper, being then raised, imprints or stamps a margin of cement thereon. The requisite margins of cement for forming overlapping joints being thus applied to the slate or other material, the cemented portions or margins are laid in contact with each other, and in a short time become firmly united, forming water-tight surfaces. Sometimes, to expedite the process, a coating of naphtha, or other spirit that will act upon the cement, or a solution, made by dissolving the cement in naphtha or other spirit, is applied to the cemented portions or margins. The cement may also be used for securing the above materials to the building, as well as to each other.

The patentee connects pieces of glass together with the above cement, when making skylights, conservatories, frames for horticultural purposes, &c. ; he also cements slate, stone, metal, and manufactured clays and cements together, or to wood, or to woven or other fabrics, and woven or other fabrics to wood, for building and other purposes ; he likewise cements pieces of leather together, for making boots and shoes, and hose or pipes for fire-engines ; also, leather and cork together, or to wood, metal, or woven or other fabrics, and woven or other fabrics to wood, for the manufacture of trunks, portmanteaus, packing-cases, and other purposes. When joining these materials, the parts must be dry, and free from dust, and should be warmed previous to receiving a coat of the cement, in order that it may not be chilled at the moment of application. If the joint is to be made at once, the parts must be expeditiously put together, and pressed, as the cement rapidly loses its heat, and becomes solidified ; but the junction may be effected at any subsequent period, by the application of heat, or the spirit or solution before described.

The patentee claims, Firstly,—the application of caoutchouc (India-rubber), in combination with other materials, for the purpose of glueing or cementing together slate, tiles, stone, and metal plates, for roofing and other building purposes ; and glass, for such building and other operations, as above described. Secondly,—the use or application of the above-described cement, glue, or composition, for the purpose of glueing or cementing together the materials above mentioned, for building and other purposes.—[*Inrolled in the Inrolment Office, December, 1843.*]

To HENRY BOOTH, of *Liverpool, Esq.*, for *improvements in the method of propelling vessels through water.*—[Sealed 16th December, 1841.]

THIS invention consists in concentrating nearly the whole force of the engine, or moving power, into one-tenth or

other small portion of each stroke of the piston, and using such concentrated force to obtain a proportionably powerful stroke with a pair of vibrating propellers or paddles; the momentum thus acquired by the vessel carrying it onward until the next stroke is given.

Motion is communicated from the main shaft of the engine, by connecting-rods, to a couple of cams, which, for the sake of distinction, may be termed 1, and 2; these cams act upon a wheel or roller at the centre of an upright lever, which vibrates upon an axis at its lower end; and they are suitably formed for moving the lever a certain distance in one direction, during one-tenth of the stroke, and bringing it slowly back again during the remaining nine-tenths of the stroke. The upper end of the lever is connected, by a rod and crank, with the shaft of the propellers, to communicate the requisite vibrating movements thereto. In Plate II., fig. 1, is a back view, and fig. 2, a side view of one of the propellers. *a*, is the propeller-shaft, upon which are affixed a pair of cast-iron discs *b*, for each propeller; to these discs are bolted two plates *c*, of rolled or forged iron, connected together at their lower ends by a plate *d*. Between the plates *c*, is a plate or valve *e*, made of plate-steel, and mounted on an axis *f*; being kept closed by a cross-bar *g*, against which the lower part of it presses, when it is forced in the proper direction for propelling the vessel (see fig. 1); but, on its return motion, the plate *e*, yields to the water, and turns on its axis into a position that will offer the least resistance, as represented in fig. 2. The action of the propeller may be reversed, when required, by lowering the cross-bar *g*, and then raising it again, after the plate *e*, has passed over it; the bar *g*, works in grooves *h*, and it is raised and lowered by means of the rods *i*, cranks *j*, and handle *k*; springs *l*, are secured to each side of the plate *e*, to prevent any violent concussion taking place between it and the bar *g*.

The propelling movement is accomplished in about one-tenth of the stroke, as above mentioned; the duty of the engine during the remainder of the stroke being to bring back the propellers, by means of the cam 2, before men-

tioned, at a slow speed, to keep up the momentum of the cams, and to raise the piston of a pneumatic cylinder, which, by its descent, is to assist the principal movement or rapid stroke of the propellers. The stroke of this piston is to the same extent as the motion of the upper end of the upright lever before described, to which the piston-rod is attached by a chain, passing over a wheel. At starting, when the piston is at the bottom of the cylinder, the air is forced in above it, to the density of 100 lbs. per square inch; then, as the cam *2*, moves the propellers slowly back, the pneumatic piston is raised, and when the stroke is finished, the area above the piston will be diminished one-half, and the density of the compressed air will consequently be 200 lbs. per square inch; which, on the return of the upright lever, will assist the engine in effecting the main stroke of the propellers. If found desirable, a small quantity of air may be admitted beneath the pneumatic piston, to act as an air-cushion, to prevent any shock at the end of the stroke.

The patentee does not claim any novelty in the moving power, but only in the propeller; in the mechanical arrangements and implements by means of which the propellers are worked; and the principle, above explained, carried into effect.—[*Inrolled in the Petty Bag Office, June, 1842.*]

To JOHN WOODHOUSE DAY, of Wellfield, in the parish of Castle Eden, in the county of Durham, colliery and land-agent, for certain improvements in apparatus to facilitate the loading of vessels with coal, culm, or cinders.—
[Sealed 6th July, 1843.]

THESE improvements consist in the employment of an apparatus, which is intended to operate as an inclined plane, to conduct the coal or other materials into the hold of the vessel, and, in so doing, distribute them more equally in the hold than can be done by the ordinary means of loading; which apparatus, in a great degree, prevents the breaking of the coal that usually takes place in letting it fall from a considerable height into the hold of the ship; and also, to a

certain extent, avoids the necessity of "trimming" as heretofore, and thereby both economizes time and labour in loading the vessel. In Plate II., fig. 1, represents a longitudinal section of a ship, with the improved apparatus temporarily attached thereto, for the purpose of loading. This apparatus is shewn more in detail, and upon an enlarged scale, in the following figures. An horizontal view of the apparatus is represented at fig. 2; and an elevation, or side view, at fig. 3. A shaft *a*, is placed across the hatchway, as shewn at fig. 2; and upon this shaft is hung, by means of hooked ends, the shoots or conductors *b, b*; one of which is shewn detached in the perspective view, fig. 4. It will be perceived, that the hooked ends of the conductors *b*, are so formed, that, on being placed upon the shaft *a*, they constitute jointed connections, by which means the conductors may be laid at any desired inclination under the deck of the vessel, as seen in fig. 1. The upper parts of the conductors *b*, are curved, and have each a raised edge, as shewn in the transverse section at fig. 5; and the elongated parts of the conductors may be slightly curved, to prevent the coal from lodging on their surfaces; there are further elongated pieces *c, c*, occasionally attached to the ends of the conductors *b, b*, by sockets and bolts, or otherwise, as shewn in fig. 3, for the purpose of conducting the coal towards the extremities of the ship; and the inclinations of the conductors are determined either by allowing them to rest upon transverse beams *d, d*, (see fig. 1), or suspending them by chains, as at *e, e*.

The above-described apparatus being placed in the vessel, as shewn at fig. 1, the coal is let down, either from waggons, spouts, or other modes of delivery, through the hatchway, on to the upper parts of the conductors *b, b*, from whence it slides down the inclines, falling over the sides and ends of the conductors, and by these means becomes equally distributed over the hold of the vessel, and the large and small portions of the coal are thereby mixed with tolerable uniformity. By the use of this apparatus, an accumulation of coal immediately under the hatchway is avoided; the breaking of the larger pieces of the coal is prevented; and the uniform loading of the vessel is greatly

facilitated; besides which advantages, very little trimming is required to fill all parts of the hold of the ship, when it has been loaded by these means.

The patentee claims the construction and adaptation of inclined conductors, applied in the manner above stated, for facilitating the loading and distribution of coal, culm, or cinders, into and over the hold of a ship or other vessel.—*[Inrolled in the Petty Bag Office, January, 1844.]*

Specification drawn by Messrs. Newton and Son.

To WILLIAM LONGMAID, of the borough of Plymouth, in the county of Devon, accountant, for an improvement in the manufacture of copper, tin, zinc, and the peroxide of iron.—[Scaled 1st January, 1844.]

THE patentee commences his specification by referring to a patent which he had previously obtained October 22d, 1842,* for treating ores and other minerals, containing sulphur, with common salt; the main object of which was to produce sulphate of soda; the metals obtained being considered as beneficial additions resulting from the process. Since that time he discovered, that, under certain circumstances, ores, containing copper, tin, and zinc, with sulphur, might be advantageously treated with salt, to obtain the metallic parts, without depending chiefly upon the profits arising from the sulphate of soda; and the present patent is the result of that discovery. The improvement consists in treating the ores of copper, tin, and zinc, with salt, in proportions below those described and claimed in the former specification.

The ores are reduced to powder, and, the quantity of sulphur which they contain having been ascertained, the patentee mixes with them a sufficient quantity of salt to render their metallic parts soluble in water; more salt being used, when the cost thereof, together with the selling price and de-

* For description of this invention, see Vol. XXIV. Conjoined Series, p. 274.

mand for sulphate of soda, will justify it; but always below the proportion of sixty parts of salt to forty of sulphur. The object of this improvement, as above stated, is to obtain the metallic parts of the ore separate, without depending upon the value of the sulphate of soda resulting from the process; and this invention is only useful in those cases where the manufacturer, from local or other causes, does not wish to produce so large a quantity of sulphate of soda as would result from the sulphur contained in the ore, if salt was used in the proportions described in the former specification.

The mixture of ore and salt is treated in the same way as under the previous patent; with the exception, that, as a reduced quantity of salt is employed, the whole may be at once mixed, before introducing it into the furnace: the charges remain from twenty to twenty-four hours on each bed of the furnace. Some ores, when so treated, are liable to flux; in such cases, about half a hundred-weight of small anthracite coal, or similar carbonaceous substance, must be mixed with each charge of a ton of mixed ore and salt, either when it exhibits symptoms of fluxing, or with all future charges of the same ore. When the charge is drawn from the furnace, it is to be lixiviated: the liquor that results from the lixiviation will contain various metallic matters, according to the nature of the ores operated upon, together with sulphate of soda and muriate of soda or chloride of sodium.

The copper contained in any liquor produced in the above manner, may be precipitated by means of iron, and milk of lime may be subsequently employed for separating the zinc. The oxide of tin separates from the liquor by gravity, with the residuary matters, which, if not sufficiently small, are to be broken, preparatory to undergoing the ordinary washing process, for the purpose of separating the oxide of tin. If the whole of the copper and zinc is not rendered soluble by the first operation, the insoluble residue may be treated with weak muriatic acid, (which can be obtained by condensing it, as it is evolved from the furnace wherein the ores are treated with salt) and from the solutions thus produced, the metals may be separated in the manner before mentioned. In carry-

ing out the above processes, peroxide of iron will also be obtained.

The patentee, in conclusion, says, he is aware that, besides under his former invention, common salt has been used in small quantities (from 10 to 12 per cent. of the ores), when operating upon ores containing copper, &c., to obtain silver, before using mercury; he does not, therefore, claim the use of common salt, in any relation of quantities, when combined with the process of amalgamation. But he claims the mode, hereinbefore described, of manufacturing copper, tin, and zinc, by causing ores, containing those metals together with sulphur, to be treated with common salt, in the proportion of less than sixty parts, by weight, of salt, to forty of the sulphur, ascertained to be contained in such ores. Also, the use of muriatic acid subsequent to the treatment with common salt, as herein described. And, likewise, the separating of iron from copper, tin, and zinc ores, when treated as above described.—[*Inrolled in the Inrolment Office, June, 1844.*]

To CHARLES CAMERON, of Liverpool, chemist, for improvements in extinguishing fires in buildings.—[Scaled 16th January, 1844.]

THIS invention consists in mixing with the water employed for extinguishing fires, any or all of the following substances: viz.—chalk, whiting, and any of the aluminous clays, reduced to a fine powder.

Every fire-engine is to be furnished with a tub or vessel, capable of containing about one hundred gallons, and divided into two compartments, a larger and a smaller, by an upright partition, pierced with numerous holes, about one-eighth of an inch in diameter. When the engine arrives at the fire, the tub is placed at the end of it, and the suction-pipe or hose is inserted into, or connected with, the smaller compartment; the chalk or other material is thrown into the larger compartment, and the water being admitted into it, the whole is kept in a state of agitation during the time the

engine is playing on the fire, by means of a broom, spade, or other instrument: additional quantities of the chalk or other material being introduced into the larger compartment, until the fire is extinguished.

The patentee claims, as his invention, the above-mentioned materials, and the manner of forming, by them, an artificial muddy water, of any degree of thickness or consistency that may be required, for smothering or extinguishing fires. He also claims them, in whatever way they may be employed in extinguishing fires, whether by means of a fire-engine, or a water-tank, placed in an elevated situation on a building. And he likewise claims the vessel above described, divided into two compartments, without regard to its shape or form.—*[Inrolled in the Inrolment Office, July, 1844.]*

To SAMUEL PARLBY, of Rutland Gate, Knightsbridge, in the county of Middlesex, retired major of the Bengal Artillery, for certain improvements in the construction of wheels for carriages.—*[Sealed 18th December, 1843.]*

THESE improved wheels are represented in Plate III., fig. 1, being a transverse section, and fig. 2, a side view of one of them, with some of the parts broken away.

In this invention, the ordinary nave is dispensed with, and the centre part of the wheel is formed by the inner ends of the spokes *a*, which are each bevilled on one side, and fit together in the manner shewn in the drawing; the bevilled side of each spoke coming against that side of the adjacent spoke which is not bevilled. Two discs *b*, are bolted upon the inner ends of the spokes, and through them a suitable hole is made, for the reception of the hollow axle-box *c*, (or any other axle-box,) when the wheel is intended to turn upon its axle; but if it is to be fixed to the axle, the hole is suitably formed for that purpose, or one of the discs *b*, is formed with a tube, which projects into the aperture in the other disc. The circumference of the wheel is formed by inserting segments of hard wood *d*, between the outer ends of the spokes, with the grain of the wood radiating from the centre of the wheel,

and bolting upon these segments and spokes, two rings e, e ; the outer edges of these rings range evenly with the wooden periphery of the wheel, so as to bear conjointly with them on the road; or the rings e, e , may be made narrower, so that the wooden periphery may bear upon the road, as shewn at figs. 3, and 4; and, in this case, the ends of the spokes have iron shoes f , and do not extend so far as in the wheel shewn at figs. 1, and 2. If preferred, a metal tire may be applied, as shewn at g , in figs. 5, and 6; and then the grain of the wooden segments may run parallel, or nearly so, to the circumference of the wheel. When intended for use on railways, the tire g , may be formed with a suitable flange; but when the tire is not employed, one of the rings e , is made of the size represented at figs. 3, and 4, and the other is considerably larger, so as to extend beyond the wooden periphery (which is to bear upon the rail), and constitute a flange of the required depth.

At fig. 1, the axle-box preferred by the patentee is represented; but to this he makes no claim, having invented it after he had petitioned her Majesty to grant him these letters patent. The box consists of a short tube h , with a hemispherical cavity i , at its front end, to contain oil, which is introduced into it through a hole, closed by a small screw; the cylindrical arm j , of the axle (see fig. 7,) fits this tube, and its end, which is convex, works in contact with the centre of the hemisphere i . The box is retained upon the axle-arm by the screw-cap k , which embraces the shoulder l , of the axle, and is screwed on the small end of the tube h ; the cap k , is preferred to be formed in two parts, in order that it may be more easily placed in its proper position upon the shoulder l , and the two parts are then connected together by passing a hoop or ring m , over them, and securing it in its place by screws. That part of the box which fits into the central hole of the outer disc b , has four small projecting pieces upon it, to fit into the four notches or key-ways formed in that disc; and when the cap k , is screwed upon the inner end of the box, it is fixed securely in the wheel. In order to render the whole of the oil in the hemispherical cavity available, to the last drop, small prominences may be formed

therein, which, as the wheel revolves, will carry up all the oil remaining in the cavity, and pour it upon the axle-arm.

Where wheels of great strength are required, as for locomotive engines, &c., two sets of spokes, of the kind above described, may be applied to each wheel.

Instead of the segments being formed of hard wood, they may be made of layers of strong leather, or of felt or other elastic substance, cemented and compressed together with great force in suitable moulds.—[*Inrolled in the Rolls Chapel Office, June, 1844.*]

To WILLIAM EDWARD NEWTON, of the Office for Patents, 66, Chancery-lane, in the county of Middlesex, civil-engineer, for an invention of certain improvements in the construction of boxes for the axles or axletrees of locomotive engines and carriages, and for the bearings or journals of machinery in general; and also improvements in oiling or lubricating the same,—being a communication.—[Sealed 15th May, 1843.]

THIS invention, which was communicated to the patentee by a certain foreigner residing abroad, consists, First, in certain improvements in the manner of making or constructing the boxes within which the gudgeons or journals of machinery of various kinds, and particularly the axles of railroad-cars, of locomotive engines, and of other cars and carriages, are to run; and these improvements are applicable, not only to boxes for axles or gudgeons, which are divided so as to form semi-cylinders, but also to boxes, bearings, or sockets, which are not divided, but form a continuous circle; and also to square sockets, or of any other desired form, and within which a rod or bar is to slide; as, for example, the guide-rods used in locomotive and other steam-engines. Secondly, this invention consists in an improved method of constructing oil-boxes for oiling the axles of locomotive steam-engines, cars, and other vehicles, and of combining the same with the lower boxes, within which such gudgeons or axles are to run.

These lower boxes are to be formed and prepared in the ordinary way of those which are to be received into the housings or plummer-blocks of locomotive engines, cars, or other machinery: they may be made of brass, bell-metal, or any other metal or metallic compound which has sufficient strength, and is capable of receiving a coating of tin. The inner parts of these boxes are to be lined with any of the harder kinds of metallic compounds or alloys, known under the names of Britannia metal or pewter, and of which compounds or alloys, block-tin is the basis. An excellent compound or alloy, for this purpose, may be prepared, by taking about fifty parts of tin, five of antimony, and one of copper; but other compounds or alloys, analogous in character, may be used.

To prepare the boxes for this composition, they are to be cast with projecting rims or fillets along their interior edges, and on their ends, within their semi-cylindrical parts; or on the ends only of the boxes or sockets, when they are not divided. The interior of these boxes, and the ledges, fillets, or rims, above named, are then to be cleaned, and tinned, in the usual way of performing that operation. A cylindrical or semi-cylindrical core, of the exact size (in its cylindrical part) of the gudgeon or axle which is to run within the bearing, or of such shape and dimensions as may be necessary for the socket of a slide or of the stem of a valve, is then taken; and upon such core the box to be lined is placed, in such a manner that the core shall coincide with the situation that the axle or gudgeon, slide or stem, is to occupy within the box, when in use. The boxes are to be of such a size, that when the core is so placed, it will not touch, but be nearly in contact with the projecting rims or fillets: its distance therefrom may be about the thirty-second part of an inch, more or less. The ends of the boxes are then to be closed by any suitable means, so that the interior shall form a mould, to receive the lining of metal, which is to be fused and poured into it, a proper aperture being prepared for that purpose. This aperture in the boxes for railroad-cars and locomotive-engines, may consist of a hole an inch, more or less, in diameter, left through their middle, in the act of

casting them; and, in all cases, the opening may be so proportioned as to suit the size of the box that is to be lined. In boxes thus prepared, the heating and abrasion, which are so apt to occur in boxes, as ordinarily constructed, do not take place, and greater durability is consequently attained.

In Plate III., figs. 1, and 2, are perspective views of a semi-cylindrical box, suited to the axle of a locomotive steam-engine, or railroad-car or carriage, as it appears before receiving the metallic alloy, with which it is to be lined. Fig. 3, is a cross section of such a box; figs. 4, and 5, are longitudinal sections through the middle of the same; and fig. 6, is a section through the socket or bush of a pulley or sheave, of the kind used in the blocks on board of vessels, and for other purposes. These several figures will serve fully to exemplify the manner in which the improvement is carried into operation. *a, a*, are the rims or fillets, along the edges of the boxes; *b, b*, those around their ends; and *c*, the hole left through the middles of the boxes, for pouring in the melted alloy to form the lining.

In figs. 2, and 5, the ledges *b, b*, near the ends of the boxes, are so situated, as to leave a projection, forming a recess or rabbet *d, d*, beyond them, at each end of the box; within which rabbet, the metallic composition or alloy is to be received, as well as within the interior of the box; and, when thus formed, the alloy received in this rabbet is adapted to the sustaining of the end bearings of the shoulders of axles or gudgeons, or of such other parts of the machinery as may run against them.

In fig. 6, *e, e*, are the ledges which confine the metallic lining that is to occupy the space between the box and the dotted lines *f, f*; the projecting parts *g, g*, are the flanges of the bush, which are to be let into the sheaves in the usual way. By the employment of the metallic alloy in sheaves, and other articles of this description, and the substitution of a hard metallic compound of copper and tin for the iron boxes, and for the iron pins or axles upon which the sheaves are to run, the injurious consequences frequently resulting from the oxidation of the iron, are obviated.

Under the first head of the invention, the patentee claims,—making or constructing the boxes within which the journals or axles of machinery are to run, or within which the rods of slides, or the stems of valves, and other analogous parts of machinery, are to slide, by providing them with rims or fillets, along their edges, and at their ends, or at their ends only, according to the nature and form of the box, in the manner, and for the purpose, herein set forth; and lining such boxes, prepared in such, or a similar manner, with a metallic composition or alloy, of which tin is the basis, for the purpose above described.

Instead of employing rims or fillets for the purpose of holding or retaining the metallic compound or alloy, other methods, such as making knobs, projections, or holes, may be adopted.

The second part of the invention consists in an improved method of constructing oil-boxes for oiling the gudgeons or axles of machinery of various kinds, and in combining the same with the lower box, within which such axles or gudgeons are to run.

In the box which surrounds the lower half of the axle of a locomotive steam-engine, railroad car, or other analogous vehicle, an oil-box, chamber, or trough, is formed; which chamber is so constructed as to have a spout or opening leading into it from the outer end of the box, through which opening oil may be supplied, so as to fill, or nearly fill, the chamber or trough. Into the said opening a tube is inserted, which is so constructed as to prevent the oil from being thrown out by any sudden concussion, even when the opening is not closed by a cover; but a cover is also provided to the said opening; which cover is borne down upon it by a spring, and closes it firmly; such spring serving also to keep the cover up when oil is to be poured into the chamber.

Through the upper side of the oil-box or chamber, an opening is made, which is immediately under the middle of the lower side of the axle; and through this opening rises one end of a weighted lever, which turns on pivots within the chamber; the raised or outer end of this lever is borne up by the weight of its lower end, and it is thus kept in con-

tact with the under side of the gudgeon or axle, which it supplies with oil by means of a flat cotton-wick, of the kind employed in Argand lamps, or by a strip of loosely woven cotton-cloth, or of any other analogous substance, which may be affixed to the outer end of the weighted lever, and which will convey the oil up from the box to the axle, by capillary attraction: the lower ends of such wick, or analogous article, being allowed continually to dip into the oil contained within the chamber.

The main body of the apparatus, containing the oil-chamber and its appendages, is usually formed in two principal parts, which may be united together by means of rivets; one of these parts constitutes the oil-box, and contains the oil-chamber, and the other forms a cap or cover, which closes the opening in the pedestal for the axle-boxes; and to this latter part is appended the cover which closes the entrance into the oil-chamber. These two principal parts may be cast together in one piece; but the making of them is facilitated by casting them separately, and subsequently uniting them by rivets, or otherwise.

Fig. 7, is a vertical section, taken through the middle of the apparatus, from front to back. Fig. 8, is a top or plan-view of the oil-box, with the cap removed. Fig. 9, represents the inner side of the cap, when separated from the oil-box, or part shewn in fig. 8: the cavity within which the axle is to be received is shewn at *A, A*; and *B, B*, is the cap or cover.

After the parts figs. 8, and 9, are cast, the two are rivetted together; the part *d*, of fig. 8, being received within the cavity *e*, of fig. 9; and then the whole may be united by two rivets passing through openings, at *a, a*, fig. 9. The opening through which the oil is to be poured, to enter the chamber *c, c*, is seen at *f*, figs. 7, and 8. This opening is occupied by a tube, shewn separately at fig. 10; it consists of two pieces, one within the other, and is so constructed as to allow the oil, when poured into its upper end, to flow freely into the oil-chamber, whilst it will prevent the return of oil through it, when the box may meet with any agitation; its exterior portion *b*, which is cylindrical, extends down to the bottom

of the oil-chamber, and has an opening made through it, as at *c*, for the passage of the oil into the oil-box *c*; *d*, is a conical tube, fitting the upper end of the tube *b*, and reaching below the opening *c*, in the outer tube, as shewn in the drawing. This manner of forming the supply-tube, effectually answers the intended purpose. As a further security, however, and to prevent the entrance of any foreign matter into the oil-chamber, a cover *g*, is employed; this cover works on a hinge-joint, and is borne upon by a spring *e*, which keeps it firmly down upon the opening *r*, or retains it, when turned up, as shewn in fig. 7. *H*, is the weighted lever, which carries upon its upper end the wick, or fibrous strip *I*; the ends of this wick are tucked through slots in the weighted lever, and extend down into the oil-chamber. The weighted lever turns on pivots in the standard *f*, placed within the oil-chamber; and its upper end, with the wick *I*, rises through an opening *κ*, in the upper part of the chamber, and is borne against the axle, as before mentioned, by the weight of its lower end.

This bearing will be thus rendered uniform, and free from the inconvenience arising from the use of springs, the tension of which has been often increased by persons having the care of them, so as sometimes to cut through the wick, or fibrous strip, in a short space of time.

When the oil-box is slipped into its place in the pedestal, under the axle, it may be retained there by passing under it a plate, having on it a spring or springs, which will force it up towards, and nearly into contact with, the said axle, and cause it to follow the motions of the upper box. The offsets or projections at *g*, *g*, are also made to catch into notches, which prevent its being drawn out, until it is suffered to drop down by the removal of the springs below it.

With reference to this part of the invention, the patentee does not claim as new,—forming the lower box of the axles of locomotive steam-engines, railroad-cars, and other vehicles, so as to contain an oil-chamber, from which oil is supplied to the lower sides of the axles, and is carried up thereto by capillary attraction; this having been effected by means of a sponge, or of a cotton-wick, borne up by springs;—but he

claims the application of the weighted lever; and the particular manner in which the said lever and its appendages are arranged, and combined with the oil-box, and with the axle, as herein set forth. And also the manner of forming and arranging the tube and its appendages, through which the oil is to be supplied to the oil-chamber, so as to prevent the escape of oil by any agitation of the box; the whole being constructed, combined, and arranged substantially in the manner above described.—[*Inrolled in the Petty Bag Office, September, 1843.*]

Specification drawn by Messrs. Newton and Son.

To THOMAS MASTERMAN, of the Dolphin Brewery, Broadstreet, Ratcliff, in the county of Middlesex, common brewer, for a certain method or mechanism for the speedy cooling of liquids, being within certain degrees of temperature; and which method or mechanism he terms a refrigerator.—[Sealed 24th February, 1844.]

AN elevation, partly in section, of the improved refrigerator, is shewn in Plate III., at fig. 1. *a*, is a cast-iron cylinder, termed the "cistern;" it is 18 inches deep, with a flange at its lower end, and a short lateral flanged pipe *d*, of $2\frac{1}{2}$ inches bore. *b*, is a cast-iron cylinder, called the "case;" it is 12 feet deep, with a flange at each end, and two short lateral pieces *e*, *f*, of $2\frac{1}{2}$ inches bore; and just above the lower flange, there is a flanged arm-hole *g*, of 6 inches diameter, closed perfectly water-tight by a door, when repairs are not going on. *c*, is another cast-iron cylinder, termed the "receiver;" it is 4 inches deep, with a flange at each end, and two short lateral pipes *h*, *i*, of $2\frac{1}{2}$ inches bore: the inner diameter of the cistern, case, and receiver, is $13\frac{1}{2}$ inches. Between the flange of the cistern and the upper flange of the case, and between the lower flange of the case and the upper flange of the receiver, a circular plate of gun-metal, one inch thick, is interposed; and in each plate 169 holes are drilled. The centre of each hole is ascertained as follows:—

From the centre of the plate, draw a radius, equal to half the inner diameter of the case ($6\frac{3}{4}$ inches); set off half an inch from the extreme end of the radius, and divide the remainder into seven equal parts; then, from the said centre, describe seven concentric circles, intersecting the radius at the several points of division thereon; then (commencing each operation at the said points, and making the parts in each circle severally equal), divide the circumference of the smallest circle into 6 parts, the next into 12 parts, and the succeeding circles into 18, 24, 30, 36, and 42 parts. Holes, five-eighths of an inch in diameter, are then drilled through each plate, at the points of division in the seven circles, and on through the centre of each plate. The tops of the holes in the upper plate are countersunk, to receive the conical heads of a series of brass tubes, which pass through the two plates. An enlarged view of one of these tubes is represented at fig. 2; they are 12 feet 3 inches long, with a bore of half an inch, and as thin as a due regard to proper strength will admit. On the lower end of each tube, a brass collar, one inch long, is soldered, having a screw-thread on its exterior, for the reception of a circular brass nut *j*, over which a leather washer is placed, when the tubes are inserted through the holes in the plates, with their conical heads resting in the countersunk holes; and then, by screwing up the nuts, the tubes are held firmly in their places: the joints are made water-tight by the application of a composition of white and red lead. The receiver *c*, has a cast-iron bottom, with a brass cock *k*, for drawing off that part of the cooled liquid which remains in the refrigerator after the operation is concluded, and also for drawing off the water afterwards run into the cistern to cleanse the tubes and receiver.

The parts *l*, *m*, *n*, correspond with the parts *a*, *b*, *c*, excepting that the cistern *l*, has two lateral pipes, instead of one, and the receiver *n*, only one lateral pipe *i*, instead of two. These parts are connected together by a pipe *o*, $2\frac{1}{2}$ inches in bore, with suitable horizontal branches, at the intersections of which a cock *p*, is placed, as shewn in section at fig. 1. One of the pipes of the cistern *l*, is connected by a pipe *q*, $2\frac{1}{2}$ inches in bore, with the pipe *h*, of the receiver

c; the remaining pipe of the cistern *l*, and the pipe *d*, of the cistern *a*, are attached to the feeding-pipes of the liquid to each cistern. The pipes *i*, of the receivers, are furnished with cocks, to regulate the flow of liquid through the tubes, so that it may be discharged from the receiver at the required temperature, which can be ascertained by inserting the bulb of a thermometer through a hole, drilled for that purpose, in each of the discharging-pipes *i*, between the receiver and the cock.

When the liquid to be cooled is contained in a shallow cooler, commonly used in breweries and distilleries, the refrigerator is fixed so that the top of its two cisterns is level with, or a few inches higher than, the upper edge of the side of the cooler: thus preventing the cisterns (which are open at the top) from overflowing. Or, where the liquid is contained in a vessel placed higher than the top of the cisterns, then the cisterns may be prevented from overflowing by a float, acting, by a lever, on a cock or valve in each of their feeding-pipes: the discharging-pipes for the liquid remaining as before described. Or these discharging-pipes may be carried upwards until they reach just above the level of the bottom of the cisterns; and, in this case, the flow of liquid through the tubes can be regulated by a cock, placed in each of the feeding-pipes: the mode of operating will in other respects be the same as described below.

The following is the mode of operating, when the spigots of the cocks *p*, are turned into a suitable position for causing the water to flow through the cases successively:—The cocks *k*, in the bottom of the receivers, being closed, a current of cold water is made to flow through the pipe *o*, (entering at the bottom,) and the lower cock *p*, into the case *m*, until it is full; then, passing through the upper cock *p*, and descending through the pipe *o*, it enters the case *b*, and ascends therein until that is also filled; it then flows out through the lateral pipe at the top of the case *b*, into the pipe *o*, again, and is carried away. The current being thus established through both cases, and the feeding-pipe of the cistern *l*, being plugged up, the liquid to be cooled is caused to run in a small stream through the other feeding-pipe into

the cistern *a*; it then descends through the tubes in the case *b*, into the receiver *c*, from which it ascends through the pipe *g*, into the cistern *l*, and thence descends through the tubes in the case *m*, into the receiver *n*: thus the two sets of tubes and the pipe *g*, will be full of the liquid. The cock of the feeding-pipe is then opened to its full extent, and the discharging-cock of the receiver *n*, is opened more or less, throughout the operation, until the liquid is discharged through it at the required temperature.

When either of the cases *b*, *m*, with their appendages, are used separately, the spigot of the upper cock *p*, is turned into a suitable position for causing the water to be carried away, after it has passed through one of the cases, instead of running down the pipe *o*, to the other case; and the pipe *g*, as well as the feeding-pipe of the cistern which is not to be used, is plugged up.

If both cases are to be used at the same time, but for cooling different liquids, the spigots of the cocks *p*, are turned into such a position as to close that part of the pipe *o*, which is between them, and to divide the current of water, entering at the lower end of the pipe *o*, into two parts; one part flowing into and out of the case *b*, and the other part into and out of the case *m*. The pipe *g*, must be plugged up; the feeding-pipe to each cistern opened; and the discharging-cock attached to each receiver must be used to discharge the liquid therefrom.

The patentee states, that by means of this refrigerator the liquid may be cooled from any degree of temperature below its boiling point to nearly the temperature of the cold water employed in the process. Where a very large quantity of liquid is required to be cooled, it is preferable, instead of immoderately increasing the number and length of the tubes in each case, to connect two or more of the above-described refrigerators by proper feeding and discharging pipes. A cylindrical case, of an inner diameter of 12 inches, will contain 127 tubes, of half-an-inch bore; and where the diameter is 15 inches, the number may be increased to 217.—[Inrolled in the Rolls Chapel Office, May, 1844.]

To EDWARD MOREWOOD, of Thornbridge, Derby, merchant,
and GEORGE ROGERS, of Chelsea, gentleman, for improved
processes for coating metals.—[Scaled May 4th, 1843.]

THE metal to be coated, according to this invention, is cleared, in the usual way, of any oxide or dirt which may be upon its surface; and when a coating of tin is first given to the metal, the following is the mode of proceeding:—A soluble salt of tin is prepared, by dissolving pieces of that metal in muriatic acid. This solution, which will be ready for use after standing about two days, is poured into a wooden tank containing water, in the proportion of two or three quarts of salt of tin to every hundred gallons of water. Zinc, in small pieces, or in a granulated state, is then sprinkled over the bottom of the tank, and the pieces of iron, or other metal, to be tinned, are placed therein; over, and between which, a further quantity of granulated zinc is distributed, so that there shall be contact in several places between the zinc and the metal to be coated. When plates are to be tinned, pieces of zinc are distributed over the bottom of the tank, as before mentioned, and upon the zinc a layer of plates is deposited; a further quantity of zinc is then thrown in, and another layer of plates placed over it, and so on, until the tank is full; care being taken that the upper plate is entirely covered by the solution. After this charge has remained from one to four hours in the tank (according to the temperature and strength of the solution: a high temperature and strong solution acting most rapidly), the plates will have received a sufficient coating. But if, by any accident or neglect, it should be found necessary to give another coating of tin to the plates, they must be taken out of the tank, and placed in a tub of cold water, while a further quantity of the solution of tin is added to the water in the tank; the process may then be proceeded with, as before; that side of the plates of metal which were before placed upward, being now reversed. The metal, thus tinned, is ready for the after process, which consists in coating metal plates with other metal in a molten state; and, for this purpose the patentees employ the appa-

ratus shewn in Plate III., by which the metal is melted, and kept in that state, while the plates are passed through it. Fig. 1, is a longitudinal vertical section of the apparatus; and fig. 2, is a cross section of the same. *a, a*, is the fire-place, over which a vessel *b, b*, to contain the molten metal, is placed. *c, c*, are rollers, mounted upon an adjustable socket *d*, attached by screw-nuts, as shewn in the drawing, to the frame *e, e*. *f*, is another roller, similarly mounted and secured to the framing *e*. Upon the right-hand end of the axle of the lower roller *c*, a cog-wheel *g*, is mounted (see fig. 3,); and on the other end of this roller is a pinion, taking into a corresponding pinion on the axle of the upper roller (see fig. 4). These rollers are for the purpose of conducting the plates to be coated, through the molten metal; and the roller *f*, is to be placed in a convenient position with regard to the rollers *c, c*, for the purpose of directing the plate upwards out of the metal, so that it may be taken hold of by pincers, and drawn out; the plate will then be found to be coated with the molten metal, through which it has passed. Motion is communicated to the rollers from any first mover, through the band and pulley *h*, to a worm *i*, on the pulley-shaft; this worm *i*, takes into a worm-wheel *j*, on one end of the shaft *k*; to the other end of which shaft, a wheel *l*, is attached, taking into the wheel *m*, (on the axle of the roller *f*,) which is in gear with the wheel *g*, before mentioned. The shaft *k*, is made in two parts, and jointed, to allow of the rising or falling of the wheel *l*, to correspond with the adjustment of the rollers. These rollers are made of wrought-iron; and if working in molten zinc, they must not be allowed to stand still, but, immediately the operation is finished, they must be withdrawn. When working, the surface of the fluid metal in the vessel *b*, is covered with a flux suitable to the metal used, as is well understood.

A modification of the above-described apparatus is represented in longitudinal vertical section at fig. 5, and a cross section at fig. 6. *n*, is a single roller, or it may be, a bar, under which the sheets of metal are conducted, for the purpose of insuring their immersion in the molten metal contained in the vessel *b*; and *o, o*, are guides, in place of the

roller *f*, which cause the plates to turn upwards, in order that they may be taken hold of, as above stated, and drawn out of the vessel.

When the plates have been cleaned, and are not wanted for immediate use, the patentees place them in a tank, containing water slightly acidulated with either muriatic or sulphuric acid: this method is also adopted, when the plates which have been submitted to the tinning process are not immediately required to undergo the next process. In coating with tin, or an alloy of tin and lead, the patentees employ the following combination as a flux,—two parts, by weight, of oil or other fatty matter, to two parts of chloride of zinc, and one of sal-ammoniac; or one of these latter ingredients may be dispensed with. It is recommended that iron plates, before they are passed through the fluid metal, should be dipped into clear water, as a great advantage will be attained by introducing them into the molten metal when in a damp state.

The claims made by the patentees are, Firstly,—the mode of coating iron and other metal, by causing it to be first submitted to a precipitation of tin, and then submitting the same to molten metal. Secondly,—the mode of coating iron and other metal, by causing sheets or other suitable surfaces thereof to pass between rollers in contact with molten metal in a suitable pot or vessel; and also causing sheets of metal to be passed under a bar, placed below the surface of molten metal, as above described. And lastly,—the application of oil or fatty matter in combination with chloride of zinc and sal-ammoniac, or either of them, as a flux, on the surface of the molten metal, when coating with molten metal: as tin, or an alloy of tin and lead.—[*Inrolled in the Inrolment Office, November, 1843.*]

To HENRY PHILLIPS, of Exeter, chemist, for improvements in removing impurities from coal gas, for the purposes of light.—[Scaled 26th January, 1843.]

THIS invention consists in purifying coal gas, by passing it

through ammoniacal liquor, the ammonia in which has been rendered caustic by lime.

The ammoniacal liquor, produced in the gas works, is put into the vessels used in the lime-washing process, and as much recently-slaked lime is added thereto as will bring it to the consistence of cream of lime; the gas is caused to pass through this mixture, which is kept in agitation by the means ordinarily adopted in the lime-washing process. When the mixture becomes no longer effective for purifying the gas, (which is ascertained by the ordinary tests,) it is withdrawn, and the vessels recharged with ammoniacal liquor and lime.

The patentee claims the application of ammoniacal liquor, in which the ammonia is rendered caustic by lime, for separating impurities from the gas obtained by the distillation of coal.—[*Inrolled in the Inrolment Office, July, 1843.*]

To CHARLES TOWNEND, of Manchester, fustian manufacturer, for an improved process or manufacture, whereby cotton fabrics are aided and made repellent to water and mildew, and any unpleasant smell is prevented in such fabrics.—[Sealed 6th March, 1844.]

THIS invention is intended to be applied chiefly to fustian cloths, called "beaverteens," although it is also applicable to other cotton fabrics; it consists in rendering the fabrics repellent to water and mildew, and preventing any unpleasant smell, by steeping them in, or passing them through, the solutions hereafter described.

As the general practice of dyers is to mix their solutions with reference to the weight of the cloth, or other material, to be immersed therein, and without regard to its length or width, the patentee describes his process upon this plan; the quantities mentioned being calculated for fabrics, of which a piece, sixty yards long, and twenty-seven inches wide, will weigh forty pounds.

To prepare a solution in which the fabrics are to be immersed, the patentee proceeds in the following manner:—

Twenty pounds of calcined British gum are mixed with eight gallons of cold water, in a suitable vessel or vat, until fine and pasty; then ten pounds of palm or white soap are dissolved in eight gallons of boiling water, in another vessel, and this solution is added to the former, together with one pint of logwood liquor, and the whole is boiled up together: three pounds of rock alum, dissolved in one gallon of water, are then added, and the mixture, after boiling for a few minutes, is ready for use. The cloth or fabric (having been previously prepared and dyed in the ordinary way) is steeped in, or passed through, the above mixture or solution, in the usual manner of stiffening and drying cotton fabrics.

Sometimes the patentee uses two solutions in succession; one of which is formed by boiling six pounds of sulphate of zinc in nine gallons of water, and, when cold, drawing off the clear solution: the other is made by dissolving twenty pounds of calcined British gum in eight gallons of cold water, and ten pounds of palm or white soap in eight gallons of boiling water, then mixing these two solutions, and, after adding a quarter of an ounce of pearlash, bringing them up to a boiling heat. The cloth or fabric is first steeped in, or passed through, the zinc solution, and is immediately afterwards steeped in, or passed through, the other solution.—
[Inrolled in the Rolls Chapel Office, May, 1844.]

Scientific Adjudication.

CIRCUIT COURT, UNITED STATES.*

(Southern District of New York.)

May 7th to 11th, 1844.

HENRY STEPHENS, OF LONDON, *v.* DAVID AND WILLARD FELT,
OF NEW YORK.

THIS action was for the alleged infringement of the plaintiff's patent for making the blue writing fluid, for ink and other coloring purposes.

The defendants admitted that they had made and sold some of the blue fluid put up in bottles as "Stephens' Blue Writing Fluid or Ink;"

* This case being among the first where a British subject is the plaintiff and inventor, we have given it at some length, for the benefit of such of our readers as are proprietors of patents in the United States.

but did not admit any particular amount ; leaving the plaintiff to make that out as well as he could. The main ground of defence relied on by the defendants was, that the plaintiff's patent was void ; because, as they alleged, the plaintiff Henry Stephens, was not the first and original inventor of the blue fluid by him claimed in his patent.

It appeared from the evidence on the part of the plaintiff, that he took out a patent in England for this discovery and invention in April, 1837,* and in this country (United States), in the October following. Of course he must have made the discovery and invention some time before the month of April, 1837 ; and it was insisted, that it was a reasonable inference from the evidence that his discovery and invention must have been early in 1837. A number of books were referred to, and proved to be standard works, to shew that Mr. Stephens' discovery and invention were unknown before his English patent in 1837 ; also a number of the most distinguished theoretical and practical chemists in the city were introduced, who proved they were well acquainted with the standard works on this subject ; and that they never had known from them, or from any other source, or from the course of their own reading or experiments, of the discovery and invention of Mr. Stephens, until they saw it in the extracts from his specification for a patent in 1837, and that they believed the invention was original and new with him.

The plaintiff introduced witnesses to prove that the defendants had manufactured large quantities of this blue ink in imitation of Stephens' Ink, procured bottles resembling Stephens' bottles, and caused to be engraved and printed large quantities of labels in close imitation of the labels on Stephens' bottles, and put these labels on the bottles of ink they sold, or offered for sale ; the counsel for the plaintiff thereupon insisted that these labels were a declaration to the world and to the purchaser of each bottle, that it was Stephens' Ink, and bound the defendants to pay for it, as such, to the plaintiff ; and that, after using these false and simulated labels, the defendants could not deny the fact that they had extensively made and sold Stephens' Ink, and that the plaintiff was entitled to damages for such manufacture and sales.

The defendants' counsel admitted that the use of these false and simulated labels was immoral and unjustifiable ; but offered to prove that the practice of using such labels on goods was common and universal among merchants and manufacturers ; to which the counsel for the plaintiff objected, as affording no excuse or justification, and of that opinion was the Court, and rejected the evidence. On the part of the defendants, a number of witnesses were introduced to shew that Mr. Stephens was not the first and original inventor of what he claimed in his patent.

Practical chemists, and the manufacturers of Prussian blue and other coloring matter, were called ; and also a person accustomed to staining paper. It was testified that in one establishment, where Prussian blue was manufactured, they made an experiment in the fall and winter of 1835 and 6, with oxalic acid, to dissolve the Prussian blue of commerce, with a view to give it a more brilliant and beautiful color—that this was their sole object in that experiment, and that their object was not to make a blue coloring fluid for writing or any other purpose ; but they expected, that when precipitated and dried

* For specification of this patent, see vol. xiii., p. 207, Conjoined Series.

they should find a more brilliant Prussian blue—that they were much surprised to find that the Prussian blue would not precipitate, but remained suspended in the water—that after letting this preparation stand for a year or more, they found that it would not precipitate, and answered none of the purposes intended. They tried a little of it as an ink and wrote a few times with it in a book on the 30th December, 1836, and 1st January, 1837, which book was produced, and they soon after threw the rest away. It did not appear from the book much like the blue fluid manufactured by Mr. Stephens, and the counsel for the plaintiff insisted that it was a different fluid.

It was strenuously contended by the counsel for the defendants, that this was substantially the same article as the one claimed by Mr. Stephens in his patent, and although the discovery and invention was accidental, yet it was not the less real; and that this discovery and use were open and known, and not kept a secret; and therefore, the plaintiff's patent was void. To which the plaintiff's counsel replied, that this single private accidental discovery by these manufacturers, while they were in pursuit of a different object, not perfected or brought out and given to the public, admitting that their recollection at this late hour was correct, ought not to invalidate this patent; and further, that it did not appear from the evidence that the materials used, when this supposed discovery was made, were reduced to the same state as Stephens reduced them, before he brought them into combined action, which produced the result which he obtained.

The defendants also introduced a witness, who had been for some years, and was yet, in their employment, to prove that he used oxalic acid in the years 1835 and 1836, as a solvent of Prussian blue for the purpose of preparing colors for paper-staining.—Several things were stated by this witness, which the counsel for the plaintiff insisted discredited him; and that very little reliance could be placed upon the knowledge which he had of the subject, or his statements in regard to it.

Two other manufacturing chemists were introduced by the defendants, to prove that at different periods, before the date of the plaintiff's invention or discovery, they had made a blue writing fluid from Prussian blue similar to that made by the plaintiff, but the plaintiff's counsel insisted that it appeared from these witnesses' own testimony, that with the Prussian blue they used another material, and in a different combination from that used by the plaintiff, and that the article, when produced, was not the same as the plaintiff's, nor was their mode of making it the same.

The above is a statement of the most material parts of the testimony in the case.

The patent was the subject of a very searching examination by the counsel for the defendants.

The Court, after commenting upon the testimony, instructed the jury on the points of law, as follows:—

1st.—The true construction of the patent is, that it secures an improvement in the use, in combination of oxalates or oxalic acid and Prussian blue, in the manner pointed out in the specification, for the purpose of manufacturing a coloring matter, and rendering the color more applicable to dyeing, staining, and writing.

2nd.—The patent is valid to this end, if the proofs show that the plaintiff is the first and original inventor of the composition claimed, and that it is useful for the purposes described in the patent.

3rd.—A claim in the patent for more than the plaintiff was the first and original discoverer or inventor of, will not avoid it, as to that which is new; and if his process, in the preparation of either of the ingredients named in his patent, was before known and used, yet, if his combination of them is new, and the result produced is new and useful, his patent is valid.

4th.—A mere abstract discovery or knowledge, by others, of the preparation of Prussian blue, as described in the patent, or the properties and effect of oxalic acid in combination with Prussian blue, unless such knowledge was in actual practical use prior to the plaintiff's discovery, will not defeat his patent.

5th.—Any prior discovery and partial use of the subject patented, however small and limited such use was, will defeat the patent, unless such use was secret, and confined to the knowledge of the discoverer alone.

6th.—The patent will be defeated if the proofs shew, that the coloring fluid claimed thereby has been before produced by the same combination of ingredients, whether the product was intended for or applied to the same purpose and use as that contemplated by the plaintiff or not, or whether or not the product was less complete and perfect in all respects than that of the patentee.

7th.—If the plaintiff's patent is sustained, the use of labels by the defendants, counterfeiting his, affords no ground for damages in this action. The jury must find damages only to cover the injury sustained by the plaintiff, by means of the manufacture and sale by the defendants of coloring matter made in violation of his patent.

And thereupon the Court committed the cause to the jury, who returned their verdict for the plaintiff, 2,000 dollars damages, liable to be increased by the Court to 6,000 dollars damages.

COURT OF EXCHEQUER.

SPECIAL SITTINGS AT WESTMINSTER.

(*Before Baron Alderson and a Special Jury.*)

June 24 and 25, 1844.

RUSSELL v. LEDSAM AND OTHERS.

The plaintiff's case in this action occupied four days of the sittings after Michaelmas term last, and was brought to a sudden termination by the indisposition of a jurymen.

Mr. BARON ALDERSON.—Gentlemen, I can hardly expect that you will have an entire and full recollection of all the evidence at this present moment; and it occurred to my mind, that as we are now renewing the matter, I had better begin by reading over to you the evidence that has already been given, without making any comments upon it, for the purpose of putting ourselves as near as we can in the position in which we were when we last met. It will take some little time, but I think it will be time well spent. Perhaps you had better open the pleadings, to let us see what the issues are.

Mr. WEBSTER then stated the pleadings.

The ASSOCIATE read the specification of Cornelius Whitehouse.

Mr. BARON ALDERSON.—Gentlemen, to sum up this matter in short, I will give you the construction which Lord Lyndhurst, Mr. Baron Parke,

and myself, in "Russell v. Cowley," which was tried in 1835, put on this specification; because there is no doubt that that would be the rule which I should lay down for you on the present occasion. If the parties are dissatisfied with my opinion upon that point, which I shall give by and by in a more formal way, they will either move it, or do what they please. The substance of the specification, according to Lord Lyndhurst's view, and the view which the Court then took of it, was welding together by circular pressure, without having what was called a *mandril* inside; that is, no internal support, on which they used to hammer the thing to be welded, in former times; instead of that, they drew it through a hole, producing thereby circular pressure—pressure constantly in the direction of the circumference, and not the direction of the radius. The pressure in that direction forces the two edges together, and thereby, they being in a fit state for welding, it causes them to unite under the heat then produced; but it is circular pressure, pressure in the circumference of the circle without any internal support. That appeared to the Court to be the principle on which the specification might be supported, and the claim of the invention maintained. There was another patent at that time put in, which made it necessary that the Court should come to that conclusion, or otherwise the invention would clearly have been identical with *James and Jones's patent*; but James and Jones's patent consisted in applying the circular pressure with the *mandril* inside. This was circular pressure without a *mandril* inside. Upon that, in the case of "Russell v. Cowley, the Court of Exchequer, which at that time consisted of Lord Lyndhurst, Baron Parke, myself, and Baron Gurney, supported this very specification and patent. At that time, there was only put in on the part of the defendant James and Jones's patent; that is not by any means unworthy of observation. Now we go on to see what the evidence is to which your attention should be called. [The learned judge then read his notes of the evidence given on the previous days.] Then Mr. Kelly, for the defendant, puts in *Cook's specification*, which was read, and which I have marked as totally different. Then *James and Jones's specification* was put in, which was read, and *Osborne's specification*, which was read. Those are prior to *Whitehouse's* invention, and those are for welding by means of a *mandril* inside. Osborne's was in 1817. Then there was *James Russell's* in 1824; that is the one in question, is it not?

Mr. WATSON.—James Russell's is the one which is for welding with or without a *mandril*.

Mr. Baron ALDERSON.—James Russell's is in 1824. Read that, if you please.

The ASSOCIATE.—"My improvement in the manufacture of tubes for gas and other purposes consists in a new mode of constructing such tubes of wrought or malleable iron. To effect this, I provide plate-iron, previously rolled to a suitable thickness, and cut into strips of such length as may be found desirable to constitute one piece or tube; these strips, in breadth, corresponding to the circumference of the tube intended to be formed. I now bend up the sides of these strips of plate-iron by swages in the usual way, so as bring the two edges of the plate as close together as possible. The bent iron is then brought into a state of fusion, by introducing it either into an air furnace or a blast furnace, and when properly heated—"

Mr. Baron ALDERSON.—So far, gentlemen, you see they are exactly

alike; this patent is exactly like the patent which we are now trying, up to the part in question. Now you will see what follows. I beg your particular attention to this part of the case, because I think it is the most important part of the whole case. You see this describes the strips precisely in the same manner as the present patent; it describes the preparing them, and then the tube is subjected to a welding heat. Now just listen.

The ASSOCIATE.—“When properly heated, is to be placed under a tilt-hammer, in an apparatus of the kind shewn in the drawing at figure 1,” &c. [Reads to the end of the specification.]

Mr. Baron ALDERSON.—You see, gentlemen, that is the question—whether that is not the principle of circular pressure? You observe what it is. The substitution of drawing for percussion is not new, that is clear. The thing is, that the substitution of drawing for percussion is not new, because that was known before, with a mandril inside. You first beat it on a mandril inside, then you draw it with a mandril inside the tube. Those were considered equivalent. Then if you beat it without a mandril, and draw it through without a mandril, is not that the same? That is the whole point.

The FOREMAN.—Percussion and drawing, my Lord, differ: there is the percussion of the tilt-hammer, a succession of blows; and in the other, to complete the process, or for some reason or other, it is drawn through the rollers.

Mr. Baron ALDERSON.—That is the finish.

FOREMAN.—Still the process is different, in my opinion.

Mr. Baron ALDERSON.—Well, that will be for you to consider by and by. I have a strong impression upon it, but it does not follow that you do not know better than I do. You must look at James and Jones's patent first, which is described thus:—It was a patent whereby to weld gun barrels by the knocking of them successively by tilt-hammers; and it then added—“Or, instead of welding the barrels by hammers, they may be welded between a pair of rollers grooved to fit the form of the barrel, the rollers having either an alternate or rotatory motion, and worked by steam, water, or other mechanical power; but we consider the hammers to be the best method, as making the soundest and most perfect barrels.”—Therefore, you see there was a patent whereby they welded by knocking them with a hammer, or by drawing them; but then it was done by having a mandril inside. Then the Court said, that is not an infringement of it, because, though welding by drawing is the same as welding by tilt-hammer, yet it is always done with a mandril inside. I don't know how you can hold both are infringements: that is the difficulty.

Mr. MONTAGUE SMITH.—Your Lordship will see that with the tilt-hammer there was no circular pressure.

Baron ALDERSON.—What is circular pressure?

Mr. M. SMITH.—It is when the circle is compressed throughout.

Baron ALDERSON.—So it is in a tilt-hammer.

Mr. M. SMITH.—I beg your Lordship's pardon.

Baron ALDERSON.—My good friend, a tilt-hammer with a groove of that sort is circular pressure.

Mr. M. SMITH.—It does not embrace the whole at the moment of the blow.

Baron ALDERSON.—Yes it does; it is not a flat hammer.

Mr. M. SMITH.—I am quite aware there is a swage, and there is a groove in the hammer, my Lord. From some experiments and draw-

ings we have made, we can shew it does not, at the moment of the blow, embrace the whole circle. The skelp, as it is put in, is not perfectly round.

Baron ALDERSON.—Yes, it is; it is so described.

Mr. M. SMITH.—Then if it fills completely the groove, there can be no blow at all. If it is precisely the same size as the groove, then it can receive no blow at all.

Baron ALDERSON.—Of course it is bigger than the groove.

Mr. M. SMITH.—It is the motion of drawing through the dies.

Baron ALDERSON.—Now, you are not going to support the judgment of the Court in “Russell v. Cowley?”

Mr. M. SMITH.—Oh, yes; fully, my Lord. It is circular pressure with motion.

Baron ALDERSON.—The principle is precisely the same.

Mr. M. SMITH.—The results are totally different. In the one case, in Whitehouse’s patent, there was success; in the other, there was no success; and your lordship will find on a little consideration of it, and upon a reference to drawings which will be put into the hands of the witnesses by and by, that they are totally different things.

Baron ALDERSON.—All that I can say, then, is, that the Court were wrong in “Russell v. Cowley.” We supported you upon a wrong principle.

Mr. M. SMITH.—I think not, my Lord. I am very impartial, because I was not in either case before to-day.

A JUROR.—Will your Lordship inform us, in what shape the iron is when put under the tilt-hammer.

Baron ALDERSON.—In the same shape as when drawn through the hole. It is a tube—closed, but *not welded*.

FOREMAN of the JURY.—We should like to see a skelp.

[A skelp was handed to the jury.]

Mr. JERVIS.—If your Lordship looks at that diagram of the skelp, you will see it cannot be circular pressure. I am sure your Lordship will be kind enough to forgive me interrupting. I understand your Lordship has expressed an opinion about James Russell’s patent.

Baron ALDERSON.—I must leave it to the jury. I throw it out that it may be discussed.

Mr. JERVIS.—If my learned friends are willing to take it upon the specification of James Russell’s patent, and your Lordship will either nonsuit the plaintiff or direct the jury to find for the defendants upon that, we shall be quite content to try it hereafter.

Baron ALDERSON.—I shall do no such thing. I shall direct the jury to find for the defendants, if they are satisfied it is on the same principle: that is a question of fact, not of law. Here the Court, in construing James and Jones’s patent, held that the welding by circular pressure by drawing it through, was equivalent to knocking by a hammer that had a groove.

Mr. JERVIS.—Your Lordship will see the distinction is not adverted to by the bench, which is the real principle of the plaintiff’s patent—circular pressure with drawing, with motion, so as to concentrate the circular pressure. That is the principle; your Lordship put that down as the principle; pressure with motion is the point.

Baron ALDERSON.—Let us go by steps; it is quite clear that a tilt-hammer is circular pressure.

Mr. JERVIS.—No, my Lord. If the body within the tilt-hammer

just fits it so as to make it come down on the circle, there is no pressure.

BARON ALDERSON.—Of course not.

MR. JERVIS.—If it is too big, there cannot be circular pressure.

BARON ALDERSON.—Which way is the pressure?

MR. JERVIS.—Up and down pressure, and only so. If a concave hammer hits so on a body larger than itself, the effect is to press it out at the sides, and there cannot be circular pressure.

BARON ALDERSON.—Just try the thing by the ordinary process of reasoning. What is the process? Why, if the thing is drawn through a hole which is smaller than the thing itself, that is circular pressure, because it is drawn through a hole smaller than the thing which is drawn through.

MR. JERVIS.—No doubt, my Lord.

BARON ALDERSON.—Then, in order to draw it through, it forces the sides against each other. Now, if the upper groove and the lower groove form a tube less than the thing hammered, they are, for the same reason, forced against each other.

MR. JERVIS.—I am quite sure your Lordship will see it perfectly plain if you will look at that diagram—[handing the diagram to the bench.] In drawing it through a die or pincer, your Lordship will find the pressure is in the exact proportion of the radii of the circle supposed to be in the centre of the die; if you hammer it, the thing being bigger, unless it is shifted, it must bulge out at the sides where there is no support; but if you keep turning it round, you cannot get a circular pressure—it is a circular hammering. There must be a space that must be hit before it is perfectly in the circle. If you will look at that diagram it will shew you in a moment. There is no pressure on each side.

[The learned Judge took Mr. Jervis's diagram and shewed it to the jury.]

A JUROR.—I have no doubt about it; it is certainly circular pressure.

THE FOREMAN.—I cannot understand it; one is constantly moving, and the other is not.

BARON ALDERSON.—When *this* thing comes down on *that*, it forces *this* into a smaller circle; still, it is circular pressure—it is not a direct pressure.

MR. JERVIS.—It never becomes circular pressure till the pressure is unnecessary.

BARON ALDERSON.—The real difference is, that the one is pressure by impact, instead of pressure by mere weight.

MR. JERVIS.—Ours is circular pressure with motion.

BARON ALDERSON.—It is pressure by impact, and impact is but a substitution for weight. The rapidity of your motion makes amends for want of weight, but you might do the same thing by pressure. You knock a nail in by pressure.

THE FOREMAN.—If you want to knock a nail in, you must take a hammer. You cannot press it in.

BARON ALDERSON.—That is because you cannot press a sufficient weight on it. Percussion is a short mode of applying pressure. What is it but pressure?

MR. JERVIS.—Perhaps we may save a considerable length of time if your Lordship will direct the jury upon that according to your present impression, that this is circular pressure.

BARON ALDERSON.—At present we are to go on with another part

of the case. That was my reason for interrupting; if there was any thing remaining that would at all affect this part of it, I would not have interposed, but the case is ripe for decision on this point. The further evidence which Mr. Watson is going to offer is, to shew there is no infringement, and that the use of the mandril was a *bona fide* use, and that they did not make pipes without a real mandril. Upon that I am going to hear evidence if necessary. I am far from saying that is not a strong case on the part of the defendants. It is for them to say whether they choose to go on; if they do not, I will hear you upon it.

Mr. WATSON.—I have got a superior power above me, my Lord, and I should like to have one word with him upon it.

Baron ALDERSON.—Where is Mr. Kelly?

Mr. WATSON.—In the House of Lords, my Lord.

Baron ALDERSON.—I will adjourn for five minutes if you like, Mr. Watson. I distinctly tell you beforehand, that I think it is a question of fact.

Mr. WATSON.—I am aware of that, my Lord.

Baron ALDERSON.—I am not going to rule any point of law. Mr. Jervis is entitled to be heard on it, and I throw it out in order that I may hear what he has to say.

Mr. JERVIS.—Upon the specification of James Russell they are not going into evidence to explain that patent.

Mr. WATSON.—There is the evidence of one of your witnesses.

Baron ALDERSON.—I made a memorandum of it; it is the evidence of a person of the name of *Hobbins*. He says—"James Russell's patent was for welding with or without a mandril. There was a tilt-hammer worked by machinery; the tilt-hammer and the anvil had each a groove; the two formed a tube—that is, the upper part of the hammer and the lower part of the anvil formed together a groove; with that we used to weld tubes, either with or without a mandril. We turned up the skelps by hand; and the only reason we did not use that was, that we did not make them fast enough to supply the market. Then the reason we used the rolling was, that one was more convenient than the other; but then it was not a new mode, because the same thing had been done with a mandril before." That is not new; it is not new to draw it through a roller instead of a tilt-hammer, because that had been done by James and Jones's patent with a mandril. You do half of James and Jones's patent.

Mr. JERVIS.—Your Lordship knows that in the ordinary practice of making these things before, they *dollied*, in which case they used a *swage* by hand. This is a *swage*—[holding up an instrument.] Now, my Lord, if they had hammered that, would that be circular pressure?

Baron ALDERSON.—Yes, it would.

Mr. JERVIS.—Our patent is for circular pressure with drawing.

Baron ALDERSON.—If you put it upon that, that it is drawing, then that is James and Jones's.

Mr. JERVIS.—James and Jones's is drawing with a mandril; ours is drawing with circular pressure *without a mandril*.

Baron ALDERSON.—Suppose a man has invented the making of tubes with a mandril inside and a tilt-hammer, and another person had said that might be done just as well by drawing it through a hole, then another person had discovered that with a tilt-hammer he could make it without a mandril—then could you not apply the latter by drawing it through a hole?

Mr. JERVIS.—Certainly not.

Baron ALDERSON.—I make it by a mandril with a tilt-hammer—the equivalent thing to that is to draw it through a hole with a mandril; I make it with a tilt-hammer without a mandril, and the equivalent thing to that is to draw it through a hole. The knowledge is the knowledge of the man who does it without a mandril, and that is James Russell. You see the Court of Exchequer say, the real essence of your patent is, that nobody before you had ever made a tube by circular pressure without a mandril; that is what they say was the essence of the invention, and so far as it appeared on the evidence then, there never was a circular tube by any pressure whatever.

Mr. JERVIS.—Never made otherwise than by hammering on a swage without a mandril.

Baron ALDERSON.—You see, if it is drawing through a hole, surely, then there is no infringement; because they don't draw it through a hole.

Mr. JERVIS.—It is the same sort of hole.

Baron ALDERSON.—If, in fact, your patent be for drawing it through a particular hole, then you must make out the infringement for doing that thing.

Mr. JERVIS.—The principle is the same as making hollow wire.

Mr. WATSON.—My learned friends say one thing, their evidence says another. Your Lordship will say upon their evidence what is the principle of their invention.

Baron ALDERSON.—If you can get out of my way James Russell's patent, I see my way as plain as possible; but I cannot see my way altogether now.

Mr. WEBSTER.—There is no pressure without motion; that is our case. Whenever motion begins—when it is drawn through the bell-mouth either with the roller or the die—whenever motion begins, then pressure begins; and if the pressure is too great, then the pipe lengthens; so that there is no analogy between the two cases, unless your Lordship thinks that hammering with a hammer with two circular holes is the same thing as drawing through a circular hole, the hole being complete and of the same size always, and the pressure being given by the motion.

Baron ALDERSON.—My difficulty is this: I think you are on the horns of a dilemma—either it is James and Jones's patent, or it is James Russell's patent: the Court held it was not James and Jones's patent, because there was no mandril; now they produce one that I think is the same.

Mr. JERVIS.—It is just between the two, my Lord.

Baron ALDERSON.—I don't say which it is, because the Court may have been wrong in coming to the conclusion they did. I cannot say which it is, but it seems to me it cannot be both. I think it will turn on a motion at last.

Mr. JERVIS.—And, therefore, the sooner we get to the motion the better.

Baron ALDERSON.—I think so too. It comes to that question after all. Then, in the meanwhile, you will go to the other point; because, if you make out that a mandril is used, there will be an end of it.

Mr. John Farey, Mr. John Barnes, and Mr. Thomas Buckle, civil engineers, were then severally called on the part of the defendants, and proved that they were the viewers appointed under an order of the Court of Chancery, to inspect the plaintiff's and defendants' processes.

The plaintiff's process is for welding butt-jointed tubes by drawing each end three or more times through *dies* or *swages* without a mandril; and that the defendants' process and practice (*under Prosser's patent*) is for welding butt and lap-jointed tubes, by means of four grooved rolls, *with* a mandril, at one operation; and that it would be impossible for plaintiff, by his process, to make lap-jointed tubes, such as manufactured by the defendants, for marine, locomotive, and other boilers.

Mr. Charles Palmer proved he was formerly manager of the defendants' works; that he was in the employment of the defendants while Mr. Prosser's invention was worked in 1840 and 1841; and that the practice was to heat a *previously prepared skelp* to a welding heat, and pass it through the rolls on a mandril. That the mandril was an essential part of the process, and that tubes could not be made without it, especially the *thin* tubes used for steam boilers: the principal use of the mandril being to keep the bore of the tube perfect, and free from *scoria*, large quantities of which were pushed by the mandrils from the insides of the tubes.

On his cross-examination the witness stated—That early in the use of the machine, (in the year 1840), "he made 100 tubes *without* a mandril;" "they were in the warehouse when I left; the fact is, they were an eighth of an inch in the bore, and six-eighths in diameter; and being a novice, I had them turned up, and when they were turned up they did not meet by a great deal; the furnace was hot; and my observation was, that if fastened together they will be more useful than they are now, in the rough state, and they have been used for jobbing purposes in the manufactory."

Mr. JERVIS.—The infringement is now proved.

Baron ALDERSON.—Here are 100 tubes made without a mandril.

Mr. ROTCH.—Through our rollers, my Lord.

Baron ALDERSON.—Still, you have made them, and *used* them.

Mr. ROTCH.—No, my Lord; I beg your Lordship's pardon.

Mr. JERVIS.—It will bring it to the other point now. I will not cross-examine another witness upon the infringement.

Mr. WATSON.—The important question is, *the general making*. We shall call evidence to prove that the general mode of making was with a mandril.

Baron ALDERSON.—We are not discussing that.

Mr. WATSON.—But it will be necessary to shew the Court of Equity that this was the only instance of making tubes without a mandril.

Baron ALDERSON.—Thank God I am not the Court of Equity, to determine the amount of tubes made; the Court of Equity will determine that for itself.

Mr. JERVIS.—I shall not cross-examine any more witnesses on that point.

Baron ALDERSON.—If the making without a mandril be an infringement, this is an infringement.

Mr. JERVIS.—There it is plain enough; it is a saving of time.

Baron ALDERSON.—There is an end of that; it is a mere question of damages.

Mr. ROTCH.—They were not made with this instrument.

Baron ALDERSON to Palmer.—Were those tubes passed through the rollers in the usual way, without a mandril?—They were.

Baron ALDERSON.—Your case is two-fold: you say, that when you used the rollers you used the mandril; and if so, inasmuch as Mr.

Jervis's client does not go for an infringement by the use of the rollers and the mandril together, then, if you have never made any tubes excepting by means of the mandril passing through the rollers, and welding in that way, you would not have committed any infringement in any view of the case; now it appears you have passed through the rollers 100 tubes without the mandril.

Mr. WATSON.—It was a mere experiment.

Baron ALDERSON.—They were made for an order.

Mr. ROTCH.—But they have not been sold, my Lord.

Baron ALDERSON.—They have been used about your own premises.

Mr. JERVIS.—It is just as much an infringement as if you had made 5000.

Baron ALDERSON.—It would do quite as well.

Mr. WATSON.—They were not sold, nor were they made for sale.

Mr. JERVIS.—In "*Muntz v. Foster*," it was held that making, without a sale, was an infringement; that was held in the Common Pleas the other day; "make, use, exercise, or vend," I think are the terms.

Baron ALDERSON.—There is no doubt this is an infringement.

Mr. WATSON.—They did not make these for sale.

Baron ALDERSON.—What he said was, "I remember 100 tubes being made, they were not sold. That was in 1840; they were made without a mandril, and were afterwards used in our manufactory."

Mr. WATSON.—For old iron.

Baron ALDERSON.—No, no; they were made for an order, but were not sold.

Mr. ROTCH.—Surely we have a right to make without a mandril, if we do not draw through the draw-bench.

Baron ALDERSON.—I don't say you have not; that is the point. I only say it brings it to a single point. I am not in the slightest degree saying your defence is not a reasonable defence; I only say this puts an end to the infringement.

Mr. WATSON.—No use were made of them. It should be shewn they were used as tubes were used.

Baron ALDERSON.—He said, "they were used in our manufactory." We will ask him, I have no doubt he tells the truth. I have no doubt he will tell you; for he gives his evidence very fairly.—To Palmer—What use was made of these tubes?—To make staples or nails, or anything of that description that a man wanted iron for. They were not used as tubes; not a morsel of them.

Mr. ROTCH.—The fact is, they were not fit to be used as tubes.

Mr. JERVIS.—They were made for an order. An order comes from the north, and they make one hundred of them without a mandril.

Baron ALDERSON.—We will just ascertain the fact. To Palmer,—You say, there was an order for some tubes to be made for a man in the north?—Yes, my Lord.

For some customer in the north?—Yes.

And you made the one hundred tubes in consequence?—Yes, my Lord.

And you manufactured them by bringing them through your rollers, but without the use of a mandril.—Yes, my Lord.

How came you not to deliver them?—I found, when the first tube was made, it was for the want of practice on my part, but I found they would not be useful; but would be more useful by being welded together than being in the state in which they were, in which we could neither open them nor make them fold together.

Why did you weld them?—Merely that they might be useful for some purpose.

What purpose would they be useful for by welding?—They were easier for a man to use, if he wanted to make a staple or anything of the jobbing kind.

Mr. JERVIS.—He sent them to Newcastle.

Baron ALDERSON.—Were they sent to Newcastle?—They were sent out, without any expectation of being received; but the parties were very importunate.

They were sent out to the order, and returned?—Yes, my Lord.

And afterwards you made use of them?—Yes. They were used, as I stated, when wanted.

Baron ALDERSON.—Surely, that is an infringement. If that be not an infringement, you will have liberty to move it. That is an infringement, *valeat quantum*; that is to say, if this be a good patent, and if “Russell v. Cowley” be good law, which you are at liberty to question.

William Richards Palmer, sworn.

Baron ALDERSON.—What is the object of this evidence now?

Mr. HENDERSON.—It only goes, my Lord, to shew the ordinary mode of working.

Baron ALDERSON.—That might be very well, if Mr. Jervis was going for damages.

Mr. JERVIS.—I am not going for damages, my Lord, and I shall not cross-examine into this matter.

Mr. HENDERSON.—This is very important for the Court of Chancery.

Baron ALDERSON.—We had better leave the Court of Chancery to take care of itself. Do not let us be kept here three or four days, because you want to take care of the Court of Chancery.

Mr. HENDERSON.—The bill is filed, for an account of all that we have done under this process. Now, supposing it to be true, that this single blundering instance is all that we have done; still, in law, and in fact, we are not liable for what we have made with a mandril; and we can shew that our practice has been always to use the mandril.

Mr. JERVIS.—You need not trouble yourself about that.

Baron ALDERSON.—If the Court of Chancery hereafter should direct an issue to try how many tubes were made one way, and how many the other, then it will be tried.

Mr. JERVIS.—The defendants, if there is to be an account, will be put upon their oaths. It is not for a Judge at *Nisi Prius* to take an account; the Master of the Court of Chancery will take it.

Baron ALDERSON.—I quite agree with you, Mr. Henderson; you are not responsible for damages for any tubes which have been made upon a mandril *bona fide* used; every body agrees to that. The question, therefore, of the verdict, will turn entirely on whether you have made one hundred tubes *without a mandril*; if so, you lose your verdict upon that point; and if they are only going for nominal damages, it really is not material how many you have made *with*.

Mr. JERVIS.—That is all we are going upon.

Mr. HENDERSON.—When it goes back, my Lord, the Court of Chancery will say, that the verdict upon our plea of “not guilty,” establishes that our general mode was to work with a *mandril*.

Baron ALDERSON.—How can I prevent the Court of Chancery from making a blunder? If you think it has any weight, I will say that, with respect to a great proportion of the evidence, I stopped it, because I thought it was immaterial on the question that came before me.

Mr. WATSON.—I want to know this from my learned friend,—does he *give up* the general use?

Mr. JERVIS.—I do not give up anything; but I do not want to have more evidence than is necessary.

Mr. WATSON.—Do you give up this question,—that the use which we make generally with the mandril is not an imitation of your patent?

Mr. JERVIS.—In answer to that question, I beg to say this, that I do not give it up; but I think it is perfectly irrelevant to this enquiry.

Baron ALDERSON.—I do not think Mr. Jervis is bound to say anything more; if you ask my opinion, I should say it is much better for us not to discuss it, because, really and truly, I am sure you do the jury a very grievous injustice if you think they will find with you on the other point, because they think on this with you; or that they will find against you on the other, because they think against you on this.

Mr. WATSON.—Your Lordship sees that one does not know until the end of the cause.

Baron ALDERSON.—I am not prepared to say, that amongst ignorant and foolish persons a prejudice might not arise; and that inasmuch as the merits of the case were with you, they would find a verdict upon this point. But I have a special jur., and a very intelligent jury, and I am quite sure they would not be led away by any such prejudice.

Mr. WATSON.—This is substantially, in one point of view, very important; if your Lordship was to tell the jury directly that what has been proved was a piracy of their patent, then the rest of our evidence that goes to prove that the mandril is what they term *bona fide* used, would be material.

Baron ALDERSON.—That would only go to diminish damages.

Mr. WATSON.—And as it is not a case for damages, I do not see why they can object to our going on with it.

Baron ALDERSON.—I should not stop it for a moment if Mr. Jervis was going for damages, because I am quite clear it would be very material with respect to damages.

Mr. ROTCH.—My Lord, there is only one point I would wish to put, if your Lordship will allow me to suggest it. There is at present upon your Lordship's notes, evidence of many other acts of ours, besides making this 100, which are said to be infringements. We are, on the evidence of your Lordship's notes, accused of having made, by means of this scorpion, tubes, and of having used the dies in the scorpion also for that purpose.

Baron ALDERSON.—I think, in point of reason and justice, that *I must take it*, that you are entitled to a new trial. If the Court comes to the conclusion that this of itself was no infringement, then you would be entitled to a new trial. I think it is clearly an infringement of itself.

Mr. ROTCH.—The evidence that we have behind is evidence which appears to me may be most important under the present circumstances, if the Court should be of such opinion; it is this,—we are prepared to shew, by all the people who work this apparatus, that we are inundated by men applying to be hired by us, from the plaintiff, merely to watch our works, and induce us to use our instruments in a different way; and we can shew that they themselves did use them, and that we did not; and then they go away and say that we are working according to the plaintiff's patent.

Baron ALDERSON.—There is your own manager, who, in answer to

an order, makes 100 tubes, and sends them to a customer, and they are returned.

Mr. ROTCH.—I mean with respect to others.

Baron ALDERSON.—If I am wrong as to this case, you ought to have a new trial.

Mr. HENDERSON.—The Court of Chancery, in giving the plaintiff leave to bring this action, intended that the decision here should govern that Court; and the intention in sending it here was not that they should snatch a verdict.

Baron ALDERSON.—The question of the validity of the patent remains to be tried.

Mr. HENDERSON.—That is one great question; but the quest on upon the plea of "not guilty" is, whether ours is or is not an infringement of theirs. It may be proper, perhaps, to give them notice; because it may become important, that if the course of evidence we are now tendering is not proceeded with, that that which was the main question, and the only question which the Court of Chancery had in view on such issue, is left out.

Baron ALDERSON.—Then the Court of Chancery should have directed an issue in point of form.

Mr. HENDERSON.—The Court of Chancery had a doubt, amongst others, whether this was a violation.

Baron ALDERSON.—What is it they are in doubt about?

Mr. HENDERSON.—They doubt, in the Court of Chancery, whether what we do is what the plaintiff has done.

Mr. JERVIS.—It was never opened in the Court of Chancery, it was never heard in Chancery; but they consented to an order as a matter of form.

Baron ALDERSON.—I will endeavour to satisfy their reasonable doubts if I can.

Mr. HENDERSON.—A doubt was suggested by the Vice Chancellor, whether our mode of operating was similar to theirs.

Baron ALDERSON.—What is your mode of operating?

Mr. HENDERSON.—Whatever it is.

Baron ALDERSON.—Tell me, hypothetically, what it is. I do not say that you or I really know what it is.

Mr. HENDERSON.—*By a mandril.* A bill is filed against us stating that we are in the habit of violating their mode.

Baron ALDERSON.—What is that mode.

Mr. HENDERSON.—That is *without* a mandril, the other is *with*; now, that being so, one question which the Court of Chancery desires to have decided is, whether in point of fact ours is the same process as theirs.

Baron ALDERSON.—It is the same substantially as theirs. If theirs be a good patent, and you make yours with a sham mandril, that is a violation of theirs. On the other hand, if theirs is to be a good patent, upon the grounds decided in "*Russell v. Cowley*," it is not a violation if you use a real mandril. Now I give you my opinion on that point.

Mr. HENDERSON.—And the Court of Chancery intended to have the question decided.

Baron ALDERSON.—And it will be decided.

Mr. HENDERSON.—Not if it be disposed of upon one single instance; what the Court of Chancery desires to know is, whether our mode of proceeding is or is not the same as theirs.

Baron ALDERSON.—The Court of Chancery desires to know whether you have infringed their patent.

Mr. HENDERSON.—But not in a single instance.

Baron ALDERSON.—If you have infringed it in one instance, you have infringed it.

Mr. JERVIS.—This is only a simple action for an infringement. If the Court of Chancery wanted anything else tried, it would have directed an issue.

Baron ALDERSON.—If the Court of Chancery waits to know whether you have habitually infringed it, let them send such an issue, if they are so foolish, and we will try it. It would be an absurd issue to send. The whole question is, whether James Russell's patent, together with James and Jones's patent, be in truth an answer to the validity of the plaintiff's patent.

Mr. JERVIS then replied; after which,

Baron ALDERSON summed up the case to the jury, in the following terms:—

“This case,” said the learned Judge, “once came before the Court of Exchequer in ‘Russell v. Cowley;’ and the Court there was very anxious, as all Courts ought to be, if they can by any reasonable and fair means, to support useful and valuable inventions, and not to turn them aside lightly by any matter that is not the essence of the thing. In modern times the Courts have been more liberal than they were in ancient times, and I believe ours has been considered to be by far the wiser course of the two. Let us see what the Court with some difficulty extracted, as being what they considered to be the principle and the real merits of the invention of Whitehouse, whose invention we are now taking into consideration. The specification is this. He describes the mode of doing it, and he says, by heating it to the point of fusion, and passing the heated iron through a pair of dies or swages, the iron becomes united, and a weld is performed, and the tube is drawn through in a welded state. Now it seems the Court, having taken a good deal of pains to consider the matter, came to this conclusion—the notion which the Court of Exchequer had at the time when this case came before them, and when they supported the patent, was, that it claimed to make the pipes without beating, or pressure, upon any hard or internal surface; that is to say, claimed to make pipes by beating or pressure, without an internal mandril, and nobody had made pipes without an internal mandril before; and if this was a specification for making without a mandril, then, so far as the case was before the Court, it was clearly a new and useful invention. The only evidence in that case was James and Jones's specification; and when you come to look at the specification of James and Jones, you find James and Jones universally speak of a mandril being used in their invention. The Court of Exchequer say, James and Jones's patent is, in some respects, like yours, because you draw it through a die, and they pass it through rollers—and there is no practical difference; but, remember, they pass it through rollers, and knock it with a hammer, with a mandril inside, and you pass it through dies without a mandril inside—and that is the distinction between you. That was the decision, gentlemen, upon which Russell v. Cowley depended; and that I apprehend to be the true title of the patent, according to the view of the Court of Exchequer. I am bound to act on that now; and you are bound to take the law from the Court of Exchequer—and are bound to take that as the reasonable construction of the Court of Exchequer. Now,

in the present case, the defendants put in, not only James and Jones's patent, which claims the making of tubes with a mandril inside—but they put in the patent of James Russell, who took out a patent for welding, by means of knocking with a circular hammer—the top being hollowed out into a groove, and the anvil being hollowed out into a similar groove—which together form the tube—the same thing in substance as pressure, and is equivalent to a roller with grooves. Then we have James Russell's, for making with or without a mandril, and taken out a year or a year and a half before Whitehouse's. Then, if that be so, and the Court of Exchequer are right in saying the real value of the invention of Whitehouse was, by welding by circular pressure, without a mandril—and, if you think that in point of fact, hammering, according to James Russell's patent, is circular pressure or circular impact, then there was an invention for welding a thing by circular impact taken out *before* the patent of Whitehouse, and therefore Whitehouse's patent was not new on the principle on which the Court of Exchequer sustained it, namely,—it being a mode for the first time of welding barrels and tubes without internal pressure arising from a mandril inside.

“Now, if the patent of Whitehouse is for drawing it through a die, as distinguished from the mere hammering or passing it through rollers, if advantage is derived from the circumstance that it is drawn from a fixed point by the drawbench, and so stretches the iron in that way, and brings it through the die—if that is the real merit of the invention, and the Court of Exchequer was wrong, then ask yourselves this question, (which is a difficult question for the plaintiff to get over)—how can you say that rollers are an infringement on that? for if the principle depends on drawing, how do rollers draw? If it is the scrubbing of the tube on the edge of the die, is there anything equivalent to that when they are passed through rollers without a mandril inside? because we must now exclude the internal mandril. If we are to exclude that against the defendants, for the purpose of making an infringement, we must exclude it for them by saying, that when doing it without a mandril, it is mere circular pressure. If it passes through rollers, it is the motion—it is the tube, going on with the roller itself, sticking to the point, and as the roller turns round, it moves it; because, as the roller turns round, it is not dragged from any portion of the roller at all, but it goes with the roller without any drawing at all; and therefore, if the essence of the plaintiff's patent be for drawing, I must say, I should recommend you to take very seriously into your consideration whether you should not find a verdict of Not guilty for the defendants?”

Mr. JERVIS.—Your Lordship will find that Cowley and Dixon, the defendants in “Russell v. Cowley,” drew by rollers without a mandril, and they held that to be an infringement.

Mr. Baron ALDERSON.—No doubt; because the Court did not hold it drawing.

Mr. JERVIS.—It was drawn by the rollers.

Mr. Baron ALDERSON.—The Court held that all pressure without an internal mandril was the principle of the invention. Therefore, gentlemen, the Court said, whether drawn or not, it is an infringement; but if they are to shift the matter, and make the *drawing* the invention, it is no infringement. The plaintiff is on the horns of that dilemma. You had better take it in the way in which the Court of Exchequer viewed it, and say whether or not you are satisfied that the circular hammering of James Russell is in truth the same thing as

circular pressure without internal support. If you are of that opinion, then I should recommend you to find the second and third issues for the defendants. The question is, whether, if the Court of Exchequer are right, James Russell's is not the same principle. If you say, Mr. Watson, I gave an opinion for defendants on the seventh issue, you had better have leave to move. You will, of course, have leave to move to enter a verdict. If I thought it was a bad plea, it is better for you to be put to move it.

The ASSOCIATE.—For whom do you find?

The FOREMAN.—For the plaintiff on all the issues.

Mr. Baron ALDERSON.—Damages, 40*s.* We take 40*s.* damages, gentlemen, to avoid any question under Lord Denman's Act.

[The defendants, it is understood, will move for a new trial next term.]

List of Patents

Granted by the French Government from the 1st of October to the 31st of December, 1841.

(Continued from page 464, Vol. XXIV.)

PATENTS FOR FIVE YEARS.

- Guigo, of Vaize, for improvements in looms.
- Guillaume, of Paris, for saw-dust paste, out of which are stamped ornaments.
- Grainé, of Saint Pons, for a machine for twisting woollen yarns.
- Mad. Hertzick, of Paris, for improved slides and buckles for suspenders.
- Hiroux, of Paris, for a coffee-pot made of glass.
- Holcroft, of Paris, for means of cooling the corn while it is ground by mill-stones.
- Keller, of Paris, for an improved cut for gloves.
- Laury Yoz, of Morez, for an improved spit.
- Lapaix, of Lille, for improvements in stringed instruments.
- Larchevêque, of Paris, for an improved watch key.
- Latasse, of Bordeaux, for a machine performing a continuous motion.
- Lebœuf, of Chamesson, for a reaping machine.
- Lebrun, of Paris, for an improved compass.
- Lefebvre and Radet, of Vaugirard, for an economical filter.
- Loos de Schelestadt, of Paris, for improvements in pavements, gutters, and sewers.
- Martin and Co. of Fourchambault, for wrought-iron wheels for rail-road waggons.
- Martin, of Paris, for improvements on the rotary machine of Galy-Cazalat.

- Mathieu Risler, of Cernay, for bands of cards made in artificial leather.
- Mège, of Paris, for carbonic and sulphurous sugar-plums.
- Morand, of Paris, for an improved gas-burner.
- Muel, of Paris, for an improved grate for kitchens.
- Muidebled and Rebulet, of Paris, for china slides for curtains.
- Muller, of Thann, for improvements in the spinning of wool.
- Pautret and Decaché, of Paris, for a machine for printing two colors at once.
- Payen, of Paris, for means of distilling liquors by steam.
- Pichon, of Boulogne, for an instrument for extracting gaseous liquors.
- Pierquin, of Martigues, for improvements in bridges.
- Pladis, of Paris, for an oven, which may be either fixed or portable.
- Pladis Gremont and Delebarre, of Paris, for improved boxes for wheels.
- Pompon, of Paris, for an improved burner for gas.
- Pruvost, of Lille, for an improved machine for sowing.
- Redée, of Batignolles, for an improved machine for extracting earth.
- Robin Morhery, of Loudéac, for the application of phosphate of lime to the manuring of land.
- Rondeau, of St. Jean-aux-bois, for a machine for winnowing corn.
- Saint Martin, of Paris, for an improved truss in caoutchouc.
- Salstonstall, of London, for an improved machine for driving piles.
- Santerre, Thillage, and Co., of Paris, for improvements in dyeing and printing woollen or other fabrics.
- Seuter, of Charonne, for the leaf and powder of artificial gold.
- Sormani, of Paris, for improved cases for receiving military and other hats.
- Stains and Sausset, of Paris, for improvements in springs for carriages.
- Viscount de Travenet, of Paris, for an hydraulic pendulum for raising water.
- Uhler, of Dijon, for a machine for sifting flour.
- Vaux, of London, for an improved horse-shoe.
- Veinée, of Geneva, for an improved plough.
- Wilson, of London, for artificial teeth.

Granted from the 1st January to the 31st March, 1842.

PATENTS FOR FIFTEEN YEARS.

- Beaussier, of Paris, represented by M. Perpigna, advocate, 2 ter, Rue Choiseul, for improvements in the tanning of skins.

- Biddle and Birkin, of Nottingham, represented in Paris by M. Perpigna, for improvements in the bobbin-net frame.
- Davis, of London, represented by M. Perpigna, for improved sealing-wax.
- Dromery, of Paris, represented by M. Perpigna, for the hot-air system applied to locomotive engines.
- Tourneyron, of Paris, represented by M. Perpigna, for improvements in carding, twisting, and spinning cotton and other fibrous substances.
- Maudslay, of London, represented by M. Perpigna, for an improved steam-engine.
- Newton, of London, represented by M. Perpigna, for improvements in locks.
- Perry, of London, represented by M. Perpigna, for improved inkstands.
- Savaresse, of Paris, represented by M. Perpigna, for apparatus for preparing gaseous liquids.
- Verdat du Tremblay, represented by M. Perpigna, for apparatus for the substitution of ethers and liquefied gases for all the purposes of steam.
- Blanc, of Paris, for the manufacture of soda, and the bleaching of sand.
- Brunier, of Paris, for a rotatory steam-engine.
- Carville, of Paris, for a machine for making bricks.
- Chambardel, of Poitiers, for an apparatus for distillation.
- Courtois, of Paris, for various systems of bricks for flues of chimneys.
- Ducarpe, Laronde, and Boudon, for clothes made without seams.
- Duvoir, of Paris, for a ventilator with a continuous action.
- Espilla, of Bordeaux, for a circular steam-engine.
- Gancel, of Rouen, for a hand-loom.
- Guyot, of Paris, for improved lamp-burners.
- Harly Perraud, of Paris, for a process of moulding loaf-sugar.
- Hussard, of Paris, for portable drains for water-closets.
- Huau, of Brest, for a new mode of making masts.
- Lecours, of Bouquiers, for a process for reducing iron ores into malleable iron.
- Lemire, of Paris, for a system of paving in wood, called *lignistat*.
- Lombardoudot, of Paris, for an anti-gas liquid to be used for lighting.
- Loos, of Schelertadt, and Berenger, Roussel, and Sterlingue, of Paris, for improvements in tanning.
- Mellet and Sarus, of Lodève, for an hydraulic wheel.

- Michel, of Marseilles, for the decoloration of palm-oils.
Milly Pariset, of Paris, for a mode of manufacturing solid and liquid substances for purposes of illumination.
Panckouke, of Paris, for a process of abbreviation in typography.
Perrot, of Rouen, for a machine for the impressions of woven fabrics.
Schlumberger, of Guebuiller, for an improved mull jenny.
Semat, of St. Pons, for a machine for washing wool and other substances.
Sisco, of Paris, for improvements in clogs and shoes.
Tammeur, of Marseilles, for an apparatus for boiling and coloring soap.
Tisserant and Charley, of Orleans, for improved pumps.
Villacroze, Desfieux, Lagrange, and Gonond, of Montmartre, for the manufacture of embossed letters.

PATENTS FOR TEN YEARS.

- Arnault, of Paris, represented by M. Perpigna, advocate, for improved suspenders.
Cliff, of St. Quentin, represented by M. Perpigna, for the bleaching of woven fabrics.
Fouschard, of Neuilly, represented by M. Perpigna, for the granulation of syrups from potato.
Huau, of Brest, represented by M. Perpigna, for improvements in the tightening of shrouds.
Sidebottom, of London, represented by M. Perpigna, for the preparation of cotton and other fibrous substances.
Andre and Baur, of Paris, for a composition of enamel called opaque enamel.
Apparuti, of Seurre, for an apparatus for manufacturing tiles to cover houses.
Bernard, of Echirolles, for an harrow with three wheels.
Boudron Porchez, of Lille, for an improved calefyer.
Collins, of London, for an apparatus to indicate the number of travellers who go in and out of an omnibus.
Cottan, of Possy, for the manufacture of soap with substances not hitherto employed.
Delamarche and Sebille, of Paris, for an improved inkstand.
Deminuid, of Comercy, for a mode of moulding iron for making horse shoes.
Desvignes and Raison, of Epinac, for economical tiles.
Dervaret, of Paris, for bleaching and washing woollen fabrics.

- Dory, of Marseilles, for the preparation of caoutchouc.
- Dumas and Goddard, of Lyons, for the mode of vitrefying panes of glass, so as to imitate embroidered muslin.
- Durand, of Bordeaux, for a safety alembic, economising fuel.
- Fabreguettes, of Paris, for a mode of setting hands for indicating seconds, applicable to all clocks.
- Genoux and Bader, of Paris, for a chemical process to fix and polish colors on stained paper.
- Grenier, of Paris, for improvements in chimneys.
- Hubert and Rouhier, of Rochelle, for the fabrication of cream of tartar.
- Huyos, of Paris, for economical stoves.
- Lange de Beaujour, of Paris, for improved fire-arms.
- Lemercier, of Epernay, for a mechanical press for lithography.
- Lowe, of London, for improvements in gas.
- Luchaire, of Orleans, for an apparatus to utilise all the heat of fire-places and stoves.
- Martin, of Toube, for lattice-work made of iron wire.
- Mathieu, of Paris, for a form in metallic cloth, applicable to all sorts of head-dresses, either civil or military.
- Matravers, of London, for a loom for weaving woollen fabrics.
- Miller Thiry, of Nancy, for a pavement in marble, or in stone.
- Nasmith, of Bordeaux, for the refining of sugar.
- Pelouze, of Paris, for the manufacture of hydrochloric acid.
- Petiet and Flachat, for joints in wrought iron, used for making cables.
- Rabiat, of Châlons, for improvements in clocks.
- Richard, of Tournon, for an apparatus for the rearing of silkworms.
- Rolt, of London, for a machine to remove sand from the bottom of rivers.
- Rosary, of Roquefort, for a motive power on the pendulum principle.
- Rouanet and Molinier, of Olargue, for an improved hydraulic machine.
- Roussel Agnus, of Gondrecourt, for cast-iron coffins.
- Sanford and Varrall, of Paris, for a reciprocating lever.
- Southwood, Stecker, and Rowley, of Birmingham, for an elastic apparatus for the fastening of clothes.
- Stewart, of London, for improvements in pianos.
- Tiesset, of Boulogne-sur-Mer, for an improved coffee-pot.
- Tranchand, of Vonneuil-sur-Vienne, for an agricultural instrument.

- Van-Hes, of Paris, for a machine for making mouldings.
 Viau, of Harfleur, for an apparatus for the preservation of life.
 Windsor, of Gand, for a machine for making felt.

PATENTS FOR FIVE YEARS.

- Ellins, of Risby Hall, represented in Paris by M. Perpigna, advocate, No. 2, ter, Rue Choiseul, for improvements in the evaporation of salt.
 Fourneyron, of Paris, represented by M. Perpigna, for improvements in the instruments used for cutting screws.
 Aubauret, of Paris, for an alimentary substance, called Arabic flour.
 Adine, of Paris, for the application of marble to the making of work-boxes of all sorts.
 Agnellet, of Paris, for a new kind of buckram.
 Arrault, of Paris, for a portable tent for surgical operations.
 Auber, of Bolbec, for a machine for printing tissues.
 Bacon, of Epernay, for a preparation of corks to prevent leakage.
 Belloc, of Bordeaux, for straps for trousers.
 Bonnard, of Grenade, for a filter applicable to wells.
 Bonnefoy and Murat, of St. Etienne, for a machine to make designs on barrels of guns and pistols.
 Bruand, of Vesoul, for improvements in billiard-tables.
 Caron, of Paris, for a new mode of driving spindles.
 Carron, of Paris, for an improved controller.
 Champollion, of Paris, for a new metal imitating silver, *maillechort, platine, &c.*
 Changarnier and Corrège, of Paris, for an apparatus to prevent the waste of flour, and the formation of paste in the gearing of mills.
 Chapsal, of Corbeil, for metallic cylinders or drums, in one, or various pieces of iron, for the transmission of motion in looms.
 Chatel, of Paris, for a mode of printing the ground colors in plain fabrics.
 Chaussenot, of Paris, for improvements in fire-places.
 Chauviert, of Rouen, for a self-acting frame for spinning cotton.
 Coiret, of Paris, for sliders for suspenders.
 Cometti and Galvani, of Paris, for the manufacture of cloth board in rilievo.
 Danvers and Lyon, of Paris, for mechanical hats.
 Déglise, of Paris, for improvements in the hanging of bells.
-

LIST OF REGISTRATIONS EFFECTED UNDER THE ACT FOR PROTECTING NEW AND ORIGINAL DESIGNS FOR ARTICLES OF UTILITY.

- June 27. *T. H. Ryland*, of Birmingham, for a rail-plate or chair.
28. *Binnion & Griffn*, of Bread-street, Hill-street, Birmingham, for a design for a lens, applicable to railway and carriage lamps, ship lights, and lamps generally.
29. *Thomas Todd & Alfred William Newbold*, of Hull, for a design for a life-preserver.
29. *Louis Marie Antoine Boiteux*, of No. 5, King-street, Golden-square, in the county of Middlesex, for "the moveable mesh knife."
29. *Thomas Halfpenny*, of St. Ann's-court, Soho, London, for a machine for cleaning knives and forks, and other like articles.
29. *Charles Lewis & Co.*, of Stangate House, Lambeth, for an improved omni-directive shower-bath.
- July 1. *Thomas Macdonald*, of Duke-street, Glasgow, for an instrument for enlarging and reducing patterns or designs.
2. *Charles Cage*, of No. 3, Willow Cottage, Canonbury, for a design for a frying-pan.
3. *Edward Boyd Roberts*, of No. 32, Moorgate-street, City, and No. 239, Regent-street, for "Roberts' hat-measuring, fitting, and shaping instrument.
3. *Joseph Hall*, of Cambridge, for a wood and metal rake.
3. *John & William Dent & Co.*, of Worcester, for a glove.
5. *John Graham*, of the firm of Kay & Hilton, Liverpool, for a design for a mill-stone, to be called "the open-skirted runner mill-stone.
6. *Walter Hancock*, of Stratford-le-Bow, for a hat-preserver and ventilator.
6. *John & William Dent & Co.*, of Worcester, for a flesh-washer or rubber.
6. *John Leach*, of Mile Town, Sheerness, Kent, for a fire-escape.
11. *Charles Peter Gavin*, of No. 39, James-street, Dublin, for a fire-plug.

- July 11. *Robert Stedall*, of No. 13, Nelson-street, Greenwich, for a chimney cowl.
13. *William Wallace*, of Lincoln, for a lounging-chair.
18. *Lawson & Holden*, of Great Charles-street, Birmingham, for a design for a rein-holder and guide, intended as a substitute for terrets, dees, &c.
24. *Henry Tilley*, of Piccadilly, Westminster, for a design for wood-paving.
26. *William Peace*, of Haigh, near Wigan, for the Elliptograph.
27. *Lawson & Holden*, of Great Charles-street, Birmingham, for a design for a socket for carriage lamps.

List of Patents

That have passed the Great Seal of IRELAND, from the 17th of June to the 16th of July, 1844, inclusive.

Henry Bewley, of 3, Lower Sackville-street, in the city of Dublin, apothecary, and chemist, and George Owen, of the same place, chemist, for improvements in the mode of confining corks or substitutes for corks, in bottles and other vessels, whether made of glass, earthen, or stone-ware, containing liquids charged or not charged with gas.—Sealed 19th June.

John Mc Bride, Manager of the Nursery Spinning and Weaving Mills, Hutcheson Town, Glasgow, in Scotland, for certain improvements in the machinery and apparatus for weaving by hand, steam, or other power.—Sealed 26th June.

Isaac Farrell, of 199, Great Brunswick-street, in the county of the city of Dublin, architect, for certain improvements in machinery whereby carriages may be impelled on railways and tramways, by means of stationary engines or other power, including certain apparatus connected with the carriages to run on the same.—Sealed 26th June.

Thomas Edmondson, of Manchester, in the county of Lancaster, mechanist, for certain improvements in printing presses.—Sealed 27th June.

George Wilkie, of Glasgow, mechanic, for improvements in machinery or apparatus for working woods into the various forms required.—Sealed 29th June.

John Stevelly, of Belfast, in the county of Antrim, in Ireland, Professor of Natural Philosophy, for improvements in steam engines.—Sealed 29th June.

Edward Cobbold, of Melford, in the county of Suffolk, clerk, M.A., for improvements in the preparation of peat, rendering it applicable to several useful purposes, particularly for fuel.—Sealed 1st July.

John Lawson, of Leeds, in the county of York, engineer, and Thomas Robinson, of Leeds, aforesaid, flax dresser, for an invention for cleaning flax, wool, silk, and other fibrous substances.—Sealed 1st July.

John Taylor, of Duke-street, Adelphi, in the county of Middlesex, Gent., for an invention of certain new mechanical combinations, by means of which economy of power and of fuel are obtained, in the use of the steam engine.—Sealed 4th July.

Edward Morewood, of Thornbridge, in the county of Derby, merchant, and George Rogers, of Stearndale, in the said county, Gent., for improvements in coating iron with other metals.—Sealed 4th July.

William Wright, of Duke-street, St. James's, in the county of Middlesex, surgeon, for certain improvements in rendering leather, skins, or hides impervious to wet, more flexible, and more durable.—Sealed 6th July.

List of Patents

Granted for SCOTLAND, subsequent to June 22nd, 1844.

To James Kennedy, of the firm of Bury, Curtis, and Kennedy, of Liverpool, engineer, and Thomas Verner, of the same place, iron ship builder, for certain improvements in the building or construction of iron and other vessels for navigation on water.—Sealed 24th June.

Charles William Graham, of King's Arms-yard, London, merchant, for improvements in manufacturing pathological, anatomical, zoological, geological, botanical, and mineralogical representations in relief; and in arranging them for use,—being a foreign communication.—Sealed 24th June.

Walter Frederick Campbell, of Islay, Esq., Argyleshire, for an im-

proved rotatory engine, to be driven by steam or other power.—Sealed 25th June.

Robert Foulerton, of the Jamaica Coffee-house, Cornhill, London, master mariner, for certain improved machinery for moving vessels and other floating apparatus.—Sealed 25th June.

Thomas Hancock, of Goswell Mews, Goswell-road, London, water-proof cloth manufacturer, for an improvement or improvements in the preparation or manufacture of caoutchouc in combination with other substances; which preparation or manufacture is suitable for rendering leather, cloth, and other fabrics waterproof; and to various other purposes to which caoutchouc is employed.—Sealed 25th June.

Edmund Morewood, of Thornbridge, Derbyshire, merchant, and George Rogers, of Steardale, in the same county, Gent., for improvements in coating iron and other metals.—Sealed 27th June.

George Wilson, of St. Martin's-court, St. Martin's-lane, London, stationer, for improvements in the cutting of paper for the manufacture of envelopes, and for other purposes.—Sealed 27th June.

Robert Dawson, of Brick-lane, London, civil engineer, and William Symington, of East Smithfield, London, civil engineer, for a method or methods of drying, seasoning, purifying, and hardening wood and other articles, either in a manufactured or unmanufactured state; parts of which are applicable to the preparation and dessication of animal, vegetable, and mineral substances.—Sealed 1st July.

William Brockedon, of Devonshire-street, Queen-square, London, for improvements in the manufacture of pills and medicated lozenges, and in preparing or treating black lead.—Sealed 8th July.

George Edmund Donisthorpe, of Bradford, top-manufacturer, for improvements in combing wool and other fibrous substances.—Sealed 8th July.

John Mc Bride, Manager of the Nursery Spinning and Weaving Mills, Hutcheson Town, Glasgow, for certain improvements in the machinery or apparatus for weaving by hand, steam or other power.—Sealed 9th July.

Moses Poole, of Serle-street, London, for improvements in the manufacture of paper,—being a foreign communication.—Sealed 11th July.

George Miller Clarke, of Albany-street, Regent's-park, London, tallow-chandler, for improvements in night lights and apparatus used therewith.—Sealed 11th July.

William Henry Phillips, of Bloomsbury-square, London, engineer, for certain improvements in the means and apparatus for subduing and extinguishing fire and saving life and property, and in obtaining and applying motive power, and improvements in propelling.—Sealed 15th July.

Edward Burton, of Basinghall-street, London, merchant, for improvements in spinning wool, cotton, and other fibrous substances,—being a foreign communication.—Sealed 15th July.

George Gwynne, of Princes-street, Cavendish-square, London, and George Fergusson Wilson, of Belmont, Vauxhall, London, for improvements in treating certain fatty or oily matters, and in the manufacture of candles and soap.—Sealed 22nd July..

New Patents

SEALED IN ENGLAND.

1844.

To Guy Carleton Coffin, of Landford, Wilts, Esq., for certain improvements applicable to locomotive, marine, and stationary engines. Sealed 3rd July—6 months for enrolment.

Anthony Lorimier, of Clerkenwell Close, Middlesex, bookbinder, for certain improvements in the apparatus and means of facilitating drawing from nature or models. Sealed 3d July—6 months for enrolment.

Henry Smith, of Stamford, agricultural implement maker, for certain improvements in the construction and arrangement of hand-rakes and horse-rakes, and in machinery for cutting vegetable substances. Sealed 3rd July—6 months for enrolment.

Charles Nossiter, of Linden End, near Birmingham, tanner, for improvements in tanning hides and skins. Sealed 3rd July—6 months for enrolment.

John George Bodmer, of Manchester, engineer, for certain improvements in locomotive steam engines and carriages, to be

used upon railways, in marine engines, and vessels; and in apparatus for propelling the same; and also in stationary engines, and in apparatus to be connected therewith. Sealed 3rd July—6 months for enrolment.

Christopher Dunkin Hays, of Bermondsey, Surrey, wharfinger, for certain improvements in propelling vessels. Sealed 3rd July—6 months for enrolment.

Octavius Henry Smith, of Wimbledon, Surrey, Esq., for certain improvements in steam-engines, boilers, and condensers. Sealed 3rd July—6 months for enrolment.

Stephen Bencraft, of Barnstaple, Esq., for improvements in the construction and fitting-up of hames, for the prevention and cure of galled shoulders to draft horses. Sealed 3rd July—6 months for enrolment.

James George Newey, of Birmingham, hook and eye manufacturer, and James Newman, of the same place, jeweller, for improvements in fastenings for wearing apparel. Sealed 3rd July—6 months for enrolment.

Thomas Syson Cundy, of Cutler-street, London, builder, for certain improvements in the construction and arrangement of stoves and fire-places. Sealed 3rd July—6 months for enrolment.

Willoughby Theobald Monzani, of Wellington-terrace, Ramsgate, Gent., for certain improvements in the construction of boats, for the preservation of life and property; and in apparatus applicable thereto. Sealed 3rd July—6 months for enrolment.

Daniel Stafford, of Grantham, Gent., for improvements in apparatus for preventing what is termed smoky chimneys or flues, and for the extinction of fire in chimneys or flues. Sealed 3rd July—6 months for enrolment.

Timothy Fisher, of Liverpool, mechanic, for improvements in locomotive engines. Sealed 10th July—6 months for enrolment.

Moses Poole, of Serle-street, Gent., for improvements in the manufacture of paper,—being a communication. Sealed 10th July—6 months for enrolment.

Moses Poole, of Serle-street, Gent., for improvements in the manufacture of oils, by using a material not heretofore employed, and in obtaining stearine therefrom, applicable in the making of candles; and also in the manufacture of manure from the

residuum of such oils with other matters,—being a communication. Sealed 10th July—6 months for enrolment.

William Bedington, Jun., of Birmingham, manufacturer, for improvements in the construction of furnaces. Sealed 10th July—6 months for enrolment.

Charles Henry Capper, of Birmingham, engineer, for a certain improvement or certain improvements in the manufacture of palisades, gates, and fences; the whole or part of which improvements may be applied to other purposes. Sealed 10th July—6 months for enrolment.

William Newton, of the Office for Patents, 66, Chancery-lane, civil engineer, for certain improvements in the manufacture of wire from zinc, and the application of the same to various useful purposes. Sealed 10th July—6 months for enrolment.

Henry Highton, of Rugby, Master of Arts, clerk, for certain improvements in electric telegraphs. Sealed 10th July—6 months for enrolment.

Robert Beart, of Godmanchester, Huntingdonshire, Gent., for improvements in apparatus for boring in the earth and in stone. Sealed 12th July—6 months for enrolment.

To John Mc Bride, Manager of the Nursery Spinning and Weaving Mills, Hutchesontown, Glasgow, for certain improvements in the machinery and apparatus for weaving by hand, steam, or other power. Sealed 15th July—6 months for enrolment.

James Harrison, of Irwell House, Lancashire, manufacturer, for certain improvements in machinery or apparatus for spinning cotton and other fibrous substances. Sealed 15th July—6 months for enrolment.

Henry Davies, of Norbury, Staffordshire, engineer, for improvements in the construction of certain steam-engines; also in the application of steam to such engines. Sealed 15th July—6 months for enrolment.

William Taylor, of Regent-street, Middlesex, Gent., F.L.S., for improvements in the manufacture of oil from a vegetable not hitherto so used. Sealed 15th July—6 months for enrolment.

Jacques Bidault, of Paris, merchant, for improvements in applying heat for generating steam, and for other purposes; which improvements may be employed to obtain power; being a communication. Sealed 17th July—6 months for enrolment.

- Charles Armengaud, of Paris, engineer, for improvements in apparatus for heating apartments and other places, and in apparatus for cooking,—being a communication. Sealed 18th July—6 months for enrolment.
- Henry Bewley, of Lower Sackville-street, Dublin, apothecary and chemist, and George Owen, of the same place, chemist, for improvements in the mode of confining corks, or substitutes for corks, in bottles and other vessels, whether made of glass, earthen, or stone-ware, containing liquids charged or not charged with gas. Sealed 20th July—6 months for enrolment.
- James Nield, of Taunton, in the State of Massachusetts, North America, for certain improvements in looms. Sealed 24th July—6 months for enrolment.
- Sarah Coote, of Clifton, near Bristol, Gloucestershire, for improvements in caulking ships, boats, and other vessels. Sealed 24th July—6 months for enrolment.
- Charles Humfrey, of Cross-lane, St. Mary-at-Hill, London, Gent., for improvements in the manufacture of candles. Sealed 24th July—6 months for enrolment.
- General George Wilson, of Cross-street, Islington, Middlesex, for certain improvements in the construction of chimneys and flues, and in furnaces, stoves, grates, or fire-places generally. Sealed 24th July—6 months for enrolment.
- William Brockedon, of Devonshire-street, Queen-square, Gent., for improvements in covering the roofs of houses and other buildings; in covering the valves used when propelling by atmospheric pressure; in covering the sleepers of railways; and in covering parts of stringed and keyed musical instruments. Sealed 24th July—6 months for enrolment.
- Joseph Hall, of Bloomfield Iron Works, Tipton, Staffordshire, ironmaster, for improvements in the manufacture of horse-shoe nails. Sealed 24th July—6 months for enrolment.
- John James Russell, and Thomas Henry Russell, both of Wednesbury, Staffordshire, tube manufacturers, for improvements in the manufacture of welded iron tubes. Sealed 24th July—6 months for enrolment.
-

CELESTIAL PHENOMENA FOR AUGUST, 1844.

D. H. M.		D. H. M.	
1	Clock before the sun, 6m. 0s.	—	Juno R. A. 7h. 3m. dec. 12. 55. N.
—	☽ rises 8h. 34m. A.	—	Pallas R. A. 15h. 39m. dec. 16. 39. N.
—	☽ passes mer. 2h. 1m. M.	—	Ceres R. A. 15h. 39m. dec. 18. 57. S.
—	☽ sets 8h. 2m. M.	—	Jupiter R. A. 0h. 13m. dec. 0. 10. S.
—	Occul. 16 Piscium, im. 12h. 43m. em. 13h. 58m.	—	Saturn R. A. 20h. 19m. dec. 20. 11. S.
2 13 58	♃ in conj. with the ☽ diff. of dec. 6. 40. S.	—	Georg. R. A. 0h. 22m. dec. 1. 36. N.
17 39	♃ in conj. with the ☽ diff. of dec. 5. 48. S.	—	Mercury passes mer. 1h. 28m.
4 3 45	♃ in conj. with the ☉	—	Venus passes mer. 21h. 50m.
10 44	♃'s third sat. will im.	—	Mars passes mer. 23h. 49m.
13 50	♃'s third sat. will em.	—	Jupiter passes mer. 14h. 31m.
5	Clock before the sun, 5m. 40s.	—	Saturn passes mer. 10h. 38m.
—	☽ rises 10h. 1m. A.	—	Georg. passes mer. 14h. 40m.
—	☽ passes mer. 5h. 1m. M.	16	Occul. B Virginis, im. 7h. 15m. em. 8h. 11m.
—	☽ sets 0h. 40m. A.	16 21 19	♃ in the descending node
—	Occul. 40 Arietis, Im. 13h. 11m em. 13h. 52m.	18	♃ greatest Hel. Lat. N.
6 3 26	☽ in ☐ or last quarter	19 12 16	♃'s fourth sat. will im.
14 58	♃'s first sat. will im.	19 12 57	♃'s second sat. will im.
22	☽ in Apogee	19 14 59	♃'s fourth sat. will em.
7 14 38	Pallas ☐ with ☉	20	Clock before the sun, 3m. 6s.
8	Occul. ♄ Tauri, im. 12h. 52m.	—	☽ rises 1h. 3m. A.
—	Occul. ♁ Tauri, im. 16h. 19m. em. 17h. 31m.	—	☽ passes mer. 5h. 24m. A.
10	Clock before the sun, 5m. 2s.	—	☽ sets 9h. 39m. A.
—	☽ rises 0h. 47m. M.	5 52	♁ greatest Hel. Lat. N.
—	☽ passes mer. 9h. 2m. M.	10 39	Ceres in ☐ with the ☉
—	☽ sets 5h. 10m. A.	21 2 16	☽ in ☐ or first quarter
—	Pallas in conj. with Ceres, diff. of dec. 36. 9. N.	3	☽ in Perigee
11 8 1	♁ in conj. with the ☽ diff. of dec. 3. 49. S.	22 13 16	♃'s first sat. will im.
14 45	♃'s third sat. will im.	25	Clock before the sun, 1m. 50s.
12 10 21	♃'s second sat. will im.	—	☽ rises 5h. 27m. A.
13 12 21	♃ in conj. with the ☽ diff. of dec. 6. 9. N.	—	☽ passes mer. 10h. 12m. A.
58	♁ stationary	—	☽ sets 1h. 49m. M.
14 2 32	Ecliptic conj. or ☉ new moon	—	Occul. ♄ Capricorni, im. 9h. 8m. em. 10h. 22m.
15	Clock before the ☉ 4m. 11s.	—	Occul. ♄ Capricorni, im. 10h. 19m. em. 11h. 32m.
—	☽ rises 6h. 33m. M.	4 56	♃ in conj. with the ☽ diff. of dec. 4. 43. S.
—	☽ passes mer. 1h. 5m. A.	26 15 33	♃'s second sat. will im.
—	☽ sets 7h. 22m. A.	27 52	♃ in Aphelion
11 21	♃'s first sat. will im.	28 34	Ecliptic oppo. or ☉ full moon
12 45	♃ in conj. with the ☽ diff. of dec. 5. 38. N.	28 5 16	♁ at the greatest brilliancy
15	Mercury R. A. 11h. 7m. dec. 5. 42. N.	29 15 10	♃'s first sat. will im.
—	Venus R. A. 7h. 33m. dec. 14. 54. N.	29 18 38	Ceres in the descending node
—	Mars R. A. 9h. 30m. dec. 15. 58. N.	58	♃ in conj. with the ☽ diff. of dec. 6. 41. S.
—	Vesta R. A. 20h. 3m. dec. 25. 56. S.	30 55	♃ in conj. with the ☽ diff. of dec. 5. 39. S.
		31 9 39	♃'s first sat. will im.

J. LEWTHWAITE, Rotherhithe.

THE
LONDON JOURNAL
AND
REPERTORY
OF
Arts, Sciences, and Manufactures.

CONJOINED SERIES.

No. CLIII.

RECENT PATENTS.

To JULIUS ADOLPH DETMOLD, of the city of London, merchant, for an invention of certain improvements in the construction and arrangement of furnaces or fire-places, applicable to various useful purposes,—being a communication.—[Sealed 18th October, 1843.]

IN furnaces employed in the different processes of the arts, and which depend for their supply of air for combustion upon the draught created by a high stack or chimney, a large proportion of the fuel is converted into combustible gases, which escape, unconsumed, out of the chimney: at certain times also, especially when the layer of fuel on the grate is very thin, a considerable portion of atmospheric air passes, undecomposed, through the fire-grate into the furnace, which, in the reverberatory furnaces employed in working metals, causes a portion of the metal that is worked in the furnace to become oxidized or wasted. The formation of combustible gases in the furnace, and the passing of undecomposed air through the grate, tend, each of them, to lower the temperature of the furnace. In addition to this, the cold or outer

air is being continually drawn into the furnace through the door when open, and through every opening or crevice that may exist in the furnace; and this also tends to diminish the heat, while at the same time it increases the waste of the metal by oxidation.

To obviate these disadvantages, the following constructions and arrangements are adopted:—Firstly, the grate or fire-chamber of the improved furnaces is made deeper than the fire-chamber or grate of the furnaces now in general use, by which means a thick stratum of fuel is always upon the grate or fire-bars; thereby preventing the passage of undecomposed air through the grate into the interior of the furnace. In ordinary furnaces, the depth of the grate, that is, the distance between the grate-bars and the top of the fire-bridge, is generally from 12 to 18 inches, and seldom exceeds 2 feet; but in the improved furnaces the depth of the grate is from 3 to 5 feet, according as the coal employed is more or less bituminous. When a caking or highly bituminous coal is used, the grate should not be less than 3 feet in depth; for a free-burning coal, 4 feet in depth; but for a very dry fuel, such as coke or anthracite coal, a depth of 5 feet will be found most advantageous.

Secondly, instead of relying upon the draught of a high chimney for the combustion of the fuel, a requisite supply of air is forced, by means of any ordinary blowing-machine, under the grate into the ash-pit, which is closed by an airtight door: thus, the blast will cause the combustion of the lower stratum of coal immediately upon the grate, and the greater portion of the gas resulting from this combustion will be a combustible gas, namely, the carbonic oxide, which is invariably produced during the process of combustion when the temperature is very high, and when the proportion of carbon is in excess to that of oxygen. The portion of carbonic acid gas which is produced by the combustion of the lower stratum of fuel, immediately upon the fire-bars, will, in its passage upwards through the superincumbent mass of ignited fuel, absorb an additional dose of carbon, and will thereby also become converted into carbonic oxide. At the same time, the carbonaceous gases contained in the fuel, such

as carburetted or bicarburetted hydrogen, will be evolved or distilled from the coal by the heat: thus, all the fuel in the fire-chamber (that is to say, all that is combustible in the fuel) is converted into combustible gases, which will pass together over the fire-bridge into the furnace.

The body of fuel in the fire-chamber, with the exception of the *stratum* resting immediately upon the grate or fire-bars, is never at a high temperature, as is ordinarily the case in furnaces, but is kept only at a red heat, which is quite sufficient to cause the formation of the combustible gases from the fuel.

Thirdly, the combustion of these gases is effected by forcing amidst them, in their passage over the fire-bridge, heated and compressed atmospheric air, supplied in numerous small streams; thereby causing a rapid and intimate combination of the oxygen of the air with the combustible gases, and consequently their perfect and immediate combustion, and a most intense temperature. The temperature of the compressed air may be regulated at will, by means of a damper, connected with the apparatus for heating the air, as will be hereafter described.

The heat, thus produced from the fuel, is also more directly applied to the purposes required than in ordinary furnaces, in which the heat is produced by the partial combustion of the fuel upon the grate, and where the metals under operation derive their temperature merely from the flame in its passage through the main or working-chamber of the furnace: whereas, by these improvements, the temperature of the fuel in the fire-chamber, where the combustible gases are generated, is comparatively low, and their actual combustion, and the intense temperature resulting therefrom, is concentrated in the very spot where the metals are placed for operation, or where the greatest heat is required.

The loss of fuel, by the escape of combustible gases at the chimney, is thus avoided; as also the diminution of temperature, and the loss of metal by oxidation, from the effects of undecomposed air passing through the grate, or through the working-door, or any openings or crevices in the furnace, as

the combustion of the gases, in the furnace, is effected under a greater pressure than that of the atmosphere without.

Furnaces of this improved construction, it is stated, may be employed with great advantage in the working of all kinds of metals, but they are of peculiar value in the different processes of the manufacture of iron.

The advantages are, first, a more intense temperature than is produced in reverberatory furnaces now in general use; secondly, an important saving of fuel; thirdly, a better yield in the working of metals, or, in other words, a diminished loss of metal from oxidation.

In Plate IV., fig. 1, exhibits a plan or horizontal section of a refining furnace for decarbonizing iron; fig. 2, a longitudinal section, taken vertically; fig. 3, a side elevation; and fig. 4, a transverse section taken in the line 1, 2, of fig. 2, and shewing the arrangement of air-heating pipes in the stack or chimney. *A*, is the fire-chamber (built of fire-brick), about 4 to 5 feet in depth, and $3\frac{1}{2}$ to 4 feet square: it is filled with the fuel, from which the combustible gases are evolved and generated. *B*, is the grate, upon which the fuel that is to be converted into gas, rests; *b, b, b*, are plates of cast iron, about 10 inches wide, which are laid upon the grate for the purpose of protecting the sides of the fire-chamber, immediately above the grate, from being burnt; for the ashes of the fuel will rest upon these plates, as shewn in the drawing by the dotted lines, and, being a nonconducting substance, will serve to keep the brickwork of the sides, immediately above the grate, from being destroyed by the action of the fire. *c*, is the ash-pit; and *D*, the door in front, by which it may be entirely closed. *E*, is an opening in one of the sides of the ash-pit, through which atmospheric air is blown into the ash-pit, by means of any ordinary blowing-machine. *F*, is the stoking-hole for filling the chamber *A*, with fuel. *G*, is a hot-air chamber, on the top of the gas-generating chamber, and from which issue a row of nozzles or blast-pipes *II, II, II*. The heated air is blown through the nozzles amidst the gases, in their passage over the fire-bridge. These nozzles are made of sheet-iron, or any other suitable material, and are about 2 inches in diameter at the larger end, and $1\frac{1}{4}$ inch at the

mouth, or smaller end, which is slightly flattened. The hot air for the combustion of the gases may be supplied also by allowing it to issue from apertures of any dimensions in the sides of pipes, conduits, or other apparatus; but this is best effected by forcing it amidst the combustible gases, through a range of tuyeres or nozzles, as above described.

The fire-bridge *l*, over which the combustible gases and the streams of heated and compressed air become mixed, and combustion effected, is made longer than in ordinary reverberatory furnaces, for the purposes of affording the hot air and gases time to become thoroughly combined, before entering the main chamber of the furnace. *κ, κ*, is the main chamber of the furnace, where the iron is refined or decarbonized; *L*, is the hearth, or bottom, made of fire-brick or fire-sand: it is supported upon cast-iron plates, the same as in ordinary puddling or heating furnaces. *м, м*, are cast-iron blocks, that surround the whole hearth, and through which a stream of cold water is made to circulate, for the purpose of protecting the sides from being destroyed by the intense heat of the melted metal and scoria. *н*, is the tapping-hole, through which the refined metal is run out from the furnace. *о*, is an arch of fire-brick, which forms the top of the gas-generating chamber, and serves to protect the hot-air chambers and nozzles from the destructive action of the fire. The arrangement and protection of the hot-air chamber and nozzles is of importance to be attended to in the application of this apparatus. For this purpose, the above-named arch of fire-brick is constructed, the pipes themselves being left exposed to the air, and their ends or mouths inserted through a range of fire-brick, and luted with fire-clay, as shewn at *р*, which connects the roof or top *о*, of the fire-chamber, with the roof or arch *q, q*, that covers the furnace. *к*, is the passage through which the combustible gases pass from the fire-chamber, over the bridge *l*, into the main chamber *κ, κ*. *s*, is the throat or flue of the furnace; and *т*, is the chimney or stack, whence the burnt gases finally escape.

υ, is the chamber, built of fire-brick, and in which an arrangement of pipes is placed, for the purpose of heating the air for the combustion of the gases, and the refining or de-

carbonizing of the iron. This chamber is separated from the chimney by a partition, having numerous openings in it, through which sufficient heat is communicated to the pipes to heat the air, which is forced through them, to the required temperature.

The temperature of the blast is regulated by causing more or less of the burnt gases to enter into the chamber v , through the openings g, g , in the brick partition, which is effected by means of a damper v , whereby the area of the passage or chimney τ , or that of the chamber v , may be diminished at will. By this means, the whole volume of the burnt gases, or any portion thereof, are caused to pass into the chamber v ; thereby increasing the temperature of the blast, without interfering with the draught of the furnace. The air may be also heated by forcing it through cast-iron boxes or pipes, placed around the hearth of the furnace, in place of the water-blocks m, m , above described; this current of air will, at the same time, serve to protect the sides from the action of the heat. This arrangement is more particularly shewn in figs. 5, and 6, which represent different views of a heating or balling furnace. v , is the working-door of the furnace, which is the same as in ordinary furnaces. w , figs. 1, and 3, is a pipe, leading from a blowing-machine, that supplies the cold blast, and from it a branch w^1 , goes off to furnish the cold blast under the grate into the ash-pit; its admission is regulated by the valve x . Another branch w^{11} , fig. 3, rises and communicates with the arrangement of pipes in the chamber v . From thence the heated air is conveyed, by the pipe w^{111} , to the hot-air chamber g , where its supply is regulated by the valve x^1 . Two branches z, z , supply the hot air for the tuyeres z^1, z^1 , which is also regulated by the valves y, y .

The mode of refining or decarbonizing iron in a furnace of this kind is as follows:—The fire-chamber A , is filled with fuel, and after it is ignited the cold blast is let on under the grate, and the combustible gases are thereby generated; the ash-pit being closed tight. The valve x^1 , is then gradually opened to admit hot air for the combustion of the gases. After the furnace has been brought to a white heat, from

twenty-five to thirty hundred-weight of pig iron is charged, and spread all over the hearth, piling it in such a manner as to leave interstices for the flame to circulate well through. When the charge is melted down quite thin, the blast of hot air is let on through the tuyeres z^1, z^1 , which, being placed so that the lines of their axes converge towards the middle of the hearth, and having a pitch of from 25 to 30 degrees, will cause the liquid iron to move round in two opposite currents; thereby exposing every part of the surface to the decarbonizing influence of the blast.

The refiner judges by trying the metal with the bar, the same as in the open finery in general use, whether it be sufficiently refined or decarbonized, which will generally be the case with a charge of twenty-five hundred-weight, in about an hour after the blast is let on through the tuyeres. The furnace is then tapped, and the metal is run in a fluid state into the mould, the same as in the ordinary process of refining in the open finery, which is well understood.

The process of refining may be hastened and facilitated by adding to the charge of crude iron about one hundred-weight or more of finery cinder, which is made in the ordinary process of refining iron in the open finery fire, and of which cinder there are generally large quantities on hand at all iron-works.

This kind of furnace may, with the greatest advantage, be employed in puddling pig or crude iron, instead of refined metal, by combining the two processes in the same furnace, whereby a very great saving of fuel and iron, as well as labour, will be produced. When employed for puddling, the hearth should be about 18 inches wider than that of the refinery furnace above described; the furnace has two doors, opposite to each other, at each of which a puddler works. About nine hundred-weight of pig-iron is charged, which, after being melted down, is subjected to the decarbonizing influence of streams of hot air from the tuyeres z^1, z^1 . After the iron is sufficiently refined, the hot blast is shut off from the tuyeres. The cinder or scoria which has been formed, and which floats on the top of the iron, is then drawn off through the working doors, by means of rables, or it may remain in the furnace until the balls are drawn out, and then run out through the

tapping-hole ; and the temperature of the furnace is slightly lowered, by partially closing the valve *x*, which admits the blast under the grate ; thus diminishing the quantity of combustible gases to be generated in the chamber *A* ; and, at the same time, as much hot air is admitted through the nozzles *H, H*, as before, thereby rendering the flame slightly oxidizing.

The mode of regulating the temperature of the furnace, during the different stages of the process of puddling, is well understood by workmen ; it being effected in the ordinary puddling furnaces, by feeding the fire on the grate, and lowering or raising the damper of the chimney. The puddler then commences to puddle and ball up, which operation is performed in precisely the same manner as in the ordinary puddling furnace, when refined metal is worked, and which is well understood.

Fig. 5, is a longitudinal section, and fig. 6, a horizontal section, of a heating, or balling, or mill furnace. It differs, in its general arrangement, but little from the refining and puddling furnaces above described. The drawings will sufficiently explain the difference, without further detailed description. The hearth is made of a thick layer of fire-sand, the same as in the ordinary heating furnaces. The air for the combustion of the gases is heated by causing it to pass through the cast-iron boxes *a, a*, which also tend to protect the sides of the furnace from the intense heat (as seen by dots in the plan view), from whence it is led by the pipe *b, b*, which is built up in the walls of the furnace, to the hot-air chamber *G*. The cinder runs off through the hole *c*, to which it is conducted by a channel made in the back of the sand bottom.

The patentee declares his invention to consist in a furnace, so constructed and arranged as to generate combustible gases in a close chamber, by a blast or current of air forced through a thick stratum of fuel ; the combustible gases generated, being burnt under a pressure greater than that of the external atmosphere, by means of heated and compressed air, injected into the combustible gases at the bridge of the furnace, or near the point at which the heat of the furnace is required to be applied.—[*Inrolled in the Petty Bag Office, April, 1844.*]

Specification drawn by Messrs. Newton and Son.

To ROBERT FOULERTON, of the Jamaica Coffee House, Cornhill, in the city of London, master mariner, for certain improved machinery for moving vessels, and other floating apparatus.—[Scaled 13th January, 1844.]

THIS invention consists in a method of turning or directing ships, barges, dredging vessels and apparatus, floating batteries, and other floating bodies, by moving them on a vertical axis, independently of, or by assisting the operation of, any of the various rudders or steering gear, or sails, at present in use.

The rudders, hitherto employed for navigation, depend for their action on the motion of the body which they steer or direct; and the objects of this invention are, Firstly,—to direct the head of the vessel to any point, when the rudder does not act, or when the vessel has neither head or stern-way. Secondly,—that the vessel may be brought about, when the rudder fails in stays, or in a heavy sea: the danger in wearing being thereby avoided. Thirdly,—to prevent the vessel from coming up in the wind, or falling off, when lying to, and got out of the trough of the sea. Fourthly,—to bring the head round in sudden shifts of wind, or when taken aback, and when there is no time to get out a boat, or the sea does not admit of lowering one. Fifthly,—to save the constant bracing about in baffling winds, by bringing the breeze on either side. Sixthly,—that the head may always be kept to the course in a calm, so as to keep station in a fleet, or “forge ahead.” Seventhly,—that the head may be brought round, in order to prevent fouling among craft and shipping, or swing clear when fouled; and that the use of boats and warps may be saved, on various other occasions, in rivers, ways, and harbours. Eighthly,—that the vessel may be worked with safety and certainty to an anchorage, and swing at anchor in calms, to keep a clear hawse and cast when getting under way. Ninthly,—that the vessel may always be brought about in beating to windward, to advantage, in short tacks, without losing her head-way, and thereby save the ground that is lost in light winds, by breaking off

and gathering way, to luff to her course; and in a fresh wind she will shoot to windward considerably in stays. Tenthly,—to enable ships of war to manœuvre more readily when going into action, and to bring their guns to bear in the event of their being disabled, even with loss of spars, rudder, or steam power.

The means employed by the patentee for effecting these objects is a submarine or under-water screw or screws, turning upon a horizontal axis, at right angles, or nearly so, to the length of the vessel; by the rotation of which, motion is given to the vessel.

In Plate V., fig. 1, is a longitudinal section of the hinder part of a vessel, and fig. 2, is a transverse section near the stern, shewing the mode of applying a screw (which the patentee terms a manœuverer) to that part of a vessel. The screw *a*, is placed in a tube or trunk *b*, and is caused to revolve, when required, by means of a band or chain, (passed around a sheave or wheel upon its shaft,) or any other suitable mode of communicating motion from the capstan, or from a winch or rigger upon any of the decks, or from the steam-engine, when applied to a steam-vessel.

In figs. 1, and 2, the connection is effected in the following manner:—From the capstans *c, c*, a shaft *d*, descends, provided with a wheel *e*, which takes into the wheel *f*, on the shaft *g*; at the other end of this shaft is a wheel *h*, gearing into another wheel on the top of the shaft *i*; this shaft descends through a stuffing-box into the tube *b*, and gives motion to the shaft of the screw, by means of the wheels *j*. When a screw is fitted at the bow, a valve (by preference a slide-valve) is applied to each end of the tube, for the purpose of closing the same, when required. Some of the screws employed by the patentee are represented at figs. 3, 4, 5, 6, 7, and 8: they may have one, two, three, or more threads or blades on the same spindle.

The patentee concludes his specification in the following words:—“I do hereby declare that I do not claim, as of my invention, the several parts hereinbefore described, except when they, or any part of them, are used in combination, for manœuvring a ship, or vessel, or floating machine or appa-

ratus, for the purpose or purposes of my invention ; which I do hereby declare to consist in moving any such floating body by the use of my manœuverer above described. And I do claim the means, one or all, above described, or any combination thereof, by which a vessel may be turned or manœuvred, when the rudder or other means are insufficient, or when they can be used to assist the rudder or other means. I claim the revolving screw or screws, fan or fans, blade or blades, when the same are placed with their axis or axes athwart-ship, with the view to turn or manœuvre a ship or vessel, or other floating body. And I do not limit my claim to the particular part of the ship, vessel, or body or apparatus, in which the same may be most conveniently placed, so as to act under water. And I claim the means of shutting or opening, at pleasure, the tube or trunk of the manœuverer, by means of the sliding valve or valves."—[*Inrolled in the Rolls Chapel Office, July, 1844.*]

To WILLIAM WATSON, Jun., of Leeds, in the county of York, manufacturing chemist, for his invention of improvements in the manufacture of sulphate, muriate, and other salts of ammonia.—[Scaled 16th January, 1844.]

It is well known to all persons conversant with the manufacture of the salts of ammonia, that the effluvia arising from such manufacture is a great annoyance to the surrounding neighbourhood : to obviate, or at any rate to lessen this inconvenience, is one of the principal objects of this invention. Various other advantages, hereafter mentioned, are stated to result from the use of this invention, which consists, in the first place, in evaporating ammoniacal liquor in close vessels, and passing the vapour or steam of such liquor through an acid solution, for the purpose of producing a salt ; instead of adopting the usual method of mixing the ammoniacal liquor and the acid together, and then evaporating it to obtain the salt in crystals ; and, secondly, in evaporating, in close vessels, the ordinary mixture of ammoniacal liquor and acid,

whereby the obnoxious gases are or may be collected, and prevented from dispersing in the surrounding atmosphere. These are the principles upon which the invention or discovery is founded: it will, however, be obvious to any person conversant with the manufacture, that the mode of operating will be somewhat different, according to the particular salt required to be produced; but still it will remain so essentially similar in principle, as to obviate the necessity of entering upon a minute description of the process, in connection with every salt.

In Plate V., various views of certain arrangements of apparatus are shown, which have been found well adapted to manufacture sulphate of ammonia. Fig. 1, represents a section of the simplest form of apparatus, which is recommended where economy is a principal object, and a very pure salt is not required to be produced. By means of this apparatus, the nuisance usually attendant on the operation is almost wholly obviated. In this figure, *a*, is an iron boiler, partly filled with gas-water, or, as it is sometimes called, gas-liquor, or ammoniacal liquor. About 260 gallons of this liquor are supplied to the boiler, and, at the discretion of the operator, a quantity of slaked lime may be added, which has the effect of hastening the operation, and producing a salt of a purer quality. A bent pipe or tube *b*, connects the boiler with a leaden vessel *c*, which is open at top. This vessel *c*, is partly filled with sulphuric acid, (if sulphate of ammonia is required,) in the proportion of about one pound weight of sulphuric acid, of the specific gravity of 1.700, to every gallon of liquor. This acid must be diluted with from three to four times its weight of water.

When the apparatus is ready charged with ammoniacal liquor and dilute acid, as above mentioned, heat is applied to the boiler *a*, and at first volatile, and apparently incondensable gases pass through the pipe *b*, into the acid solution in the vessel *c*: the heat being continued, ammonia and steam proceed from the boiler into the vessel *c*, through small perforations made in the inverted funnel, at the end of the pipe *b*, and the ammonia coming into contact with the acid, immediately combines with it, and its further progress

is arrested; but the steam which comes over with the ammonia soon raises the temperature of the acid solution in the vessel *c*, and will then escape therefrom uncondensed, so that the bulk of the liquor in the vessel is not materially increased. When all the acid in the vessel *c*, is completely neutralized, or, in other words, when the liquor is well saturated with ammonia, the contents of the vessel *c*, may be allowed to settle for a short time; it is then drawn off by the syphon *d*, into another vessel *e*, which is made of lead, or lined with lead, and is there left to crystallize. Supposing this to have been one day's operation, the crystals will form during the night, and the mother liquor may be drawn back again into the vessel *c*, and supplied with more acid for a second operation; before commencing which, the boiler *a*, must be emptied, by means of the aperture *f*, and replenished with fresh ammoniacal liquor.

A more complete form or arrangement of apparatus is shewn, in longitudinal section, at fig. 2; by which apparatus the escape of noxious or disagreeable vapours is, to a great extent, if not entirely, prevented. The boiler, containing the ammoniacal liquor, is seen at *a*; *b*, is the pipe for conducting the vapours from the boiler to the leaden vessel *c*, which, in this instance, is closed at top. Into the boiler from 250 to 280 gallons of gas-liquor are poured, and into the leaden vessel *c*, as many pounds of sulphuric acid, of the specific gravity above mentioned, as gallons of gas-water in the boiler. This acid is diluted with about three or four times its volume of water; and if it is thought desirable to add slaked lime to the ammoniacal liquor in the boiler *a*, about one hundred-weight of lime for every 220 gallons of liquor may be supplied. The leaden vessel *c*, is charged by means of the funnel *g*, and the uncondensed steam and gases are carried off therefrom by the pipe *h*, and are made to traverse a bent pipe *i*, in the flat vessel *j*, which is shewn detached, and in plan, at fig. 3. The end of the pipe *i*, is connected to another pipe, which descends into a small vessel *k*, which, having a stream of cold water continually passing through it, causes the steam and obnoxious vapours to be entirely condensed, instead of being diffused, or allowed to escape into

the surrounding atmosphere. When the acid in the vessel *c*, is neutralized, it is drawn off into the vessel *l*; and after it has been allowed to settle, it is drawn off into another vessel or reservoir *m*, where it is allowed to remain until all impurities have subsided; it is then pumped up, as found convenient, into the flat vessel *j*, where it is partially evaporated by the heat of the steam which is passed from the acid vessel *c*, through the bent pipe *i*. The concentrated solution is then let off into the crystallizing vessel *n*, and a crop of fine clean and beautiful crystals may be obtained, which should be placed on the inclined drainer *o*, to dry.

The improvements which constitute the second part of this invention, consist in preventing or considerably diminishing the nuisance arising from the manufacture of salts of ammonia, when made from gas-water.

In the manufacture of sulphate of ammonia, it is common to neutralize the gas-water with sulphuric acid; and in the manufacture of muriate of ammonia, to use muriatic acid or muriate of lime. In any of these cases an impure solution of an ammoniacal salt is obtained, which furnishes crystals by evaporation. Now it is the evaporation and dispersion of the obnoxious vapours in the air which cause the nuisance to the surrounding neighbourhood; and to obviate this the patentee employs a close vessel or boiler, and the steam and obnoxious vapours which are driven off by evaporation, instead of being allowed to escape into the open air, are confined, and conducted through pipes or vessels, kept at a low temperature by an external application of cold water, or other means; the vapours are thereby condensed in a manner similar to the common methods of distillation, as shewn at fig. 4, and, being brought into a liquid form, may be more conveniently disposed of. The solution of ammoniacal salts, which is formed by mixing the gas-liquor with any acid, is put into the boiler *a*, and heat being applied thereto, the steam or vapours arising will be driven off through the pipe *b*, into the worm or bent tube in the vessel *g*, below, which is kept constantly supplied with a stream of cold water, to condense the vapours. Instead of passing the steam and vapours through a bent pipe or worm, in the manner just described, they may be conducted from

the boiler into a vessel similar to that shewn at *k*, in fig. 2, which, being supplied with a stream of cold water, accomplishes the same object, namely, the condensation of the steam and vapours arising from the boiler. If thought preferable, the boiler may be first charged with the proper quantity of ammoniacal liquor, and the acid solution poured into it, in small quantities, through the funnel *p*. This, however, is left entirely to the discretion of the operator.

When the liquor in the boiler is sufficiently concentrated, by the evaporation of a portion of its aqueous particles, it is drawn off through the aperture *t*, into any convenient vessel, where it is crystallized.

The principal advantages resulting from the employment of the improved process and apparatus are stated to be, firstly,—a considerable saving in fuel, as, by the improved process, it is not necessary to evaporate more than about one half of the ammoniacal liquor from which the salts are obtained, for the ammonia, being more volatile than the other ingredients, will consequently escape first; secondly,—the operation being carried on in closed instead of open vessels, a saving is effected in the product, for when open vessels are employed, some of the salt is volatilized and lost; thirdly,—instead of the impure and discolored salt produced by the old process, a clean salt of considerable purity may be obtained; and fourthly,—the escape of noxious gases, at present attendant on the manufacture of ammoniacal salts, is prevented.

When salts of a more volatile nature than sulphates, such as muriates, are required, care must be taken to keep the acid vessel *c*, cool, by surrounding it with a jacket of cold water, or by other means. The arrangements of some of the other parts of the apparatus will also require to be somewhat altered, to meet the peculiar circumstances of the case, as will be well understood.

The patentee claims, Firstly,—evaporating ammoniacal liquor or gas-water, in close vessels, and passing the vapours of such liquor through an acid solution, so as to produce the required salt; and Secondly,—in evaporating, in close vessels, the ordinary mixture of ammoniacal liquor and acid, and condensing the vapours arising from such evaporation, by

passing them through pipes or vessels, kept cold by an external application of cold water, as shewn and described in reference to fig. 4, or by any other convenient means, or by passing such vapours through a stream or body of cold water, as above described.—[Inrolled in the Petty Bag Office, July, 1844.]

Specification drawn by Messrs. Newton and Son.

To MARGARET HENRIETTA MARSHALL, of Manchester, in the county of Lancaster, for a certain improved plastic composition, applicable to the fine arts, and to useful and ornamental purposes.—[Scaled 5th October, 1843.]

THIS improved plastic composition, denominated by the inventor "patent intonaco," consists of the following formula:—To six parts, by measure, of vegetable gluten, gelatine, or albumen, add one part of animal gluten, gelatine, or albumen, boiled to the consistence at which a joiner uses his glue; add one twenty-fourth part of oil, or of animal fat; and if the vegetable matters used be (as most British vegetables are) deficient in the principle of caoutchouc, this must be supplied by adding a forty-eighth part of India-rubber. These materials, called the "bind," must be very intimately united, and when at the boiling point, or not much below it, must have from thirty to thirty-four pounds of sulphate of lime worked into them till quite smooth. This is the pure intonaco. To bring the above to weight, instead of measure, and assuming rice or starch of any kind as the vegetable used, then it will be thus:—One pound of vegetable matter, a quarter of a pound of animal matter, half a pound of oil or animal fat, a quarter of a pound of India-rubber, twelve pounds of water, and thirty pounds of sulphate of lime. These proportions may be changed, or even reversed; the product will still be a substance extremely plastic when wet, and extremely hard when dry; but these are given as the proportions productive of the best results. Any vegetable gluten, gelatine, or albumen, even that from sea-weed, may be used; but the product of boiled

rice, Indian wheat, buck-wheat, wheat-flour, sago, tapioca, arrow-root, and starch of every description, is the best. When too much damaged to be used for food, these articles are still available for making this intonaco, provided the glutinous quality has not been destroyed by fermentation or otherwise. Any animal gluten, gelatine, or albumen, may be used, even the water in which fish has been boiled; but the product obtained by using common joiner's glue (or the glue obtained by macerating bones in weak muriatic acid) is the best. Any kind of oil or animal fat may be used; but the product obtained by the use of linseed oil is preferred. The best and most convenient form of India-rubber for making the intonaco, is Macintosh's patent India-rubber varnish. The intonaco being made as above, it must be worked up into the state suited for the purpose to which it is to be applied: if for plastering walls, it must be used of rather thicker consistency than common plaster. The walls must be brought to a smooth surface by the use of common lime or mortar, and the intonaco applied one-fourth of an inch in thickness, and at once brought to a fine surface, skimming being neither necessary nor advantageous to it. When fully set, it is to be polished, by using a wet Water-of-Ayr stone, or any other method the operator finds best: it will polish better when quite dry, but the operation is then more tedious. The time requisite for the intonaco to set will vary from two to seven hours, but it may be detained for any number of hours, up to twenty-four, by the addition of a certain proportion of pure sulphate of barytes, and its best qualities are at the same time heightened by this mixture: it dries in from twenty-four to forty-eight hours. When intended to make imitation of marble, the pieces of colored intonaco are to be stuck upon the wall, or any other surface, in the proper pattern, and then trowelled smooth. Pillars, pilasters, &c., may be made with lath, well spread with good lime, and the intonaco applied when the lime is nearly but not quite dry, or it may be re-damped for the purpose. When intended to be colored all through, the color must be intimately mixed with the bind, previous to adding the sulphate of lime. The pure intonaco will firmly agglomerate any pulverized body,

even metal filings, mixed with the boiling bind, before the sulphate of lime is added. A useful species of fuel may even be made, by agglomerating with it saw-dust and coal-culm : it burns not unlike charcoal. The following are the best proportions for the cement for architectural use :—Into six quarts of the bind (at the heat above mentioned,) work in eighteen pounds of dry hill or river sand, and two pounds of white or red lead, as the color may be desired ; when fully combined, add as much sulphate of lime as will bring it to the desired thickness, and spread it immediately ; when dry, it is very hard, and by repeated coats of oil may be rendered waterproof, and also very highly fire-proof. If the sand cannot be procured dry, then the strength of the bind must be as much increased as will balance the probable quantity of water introduced by the sand ; but dry sand is best. The following may be named as the principal uses of the intonaco :—First,—as a fire- and water-resisting plaster for walls, interior and exterior ; second,—imitations of marble and other stones ; third,—architectural mouldings and ornaments ; fourth,—for covering the unplanted side of fruit walls, to prevent the radiation of heat on that side, so that it takes place entirely on the side with the plants ; and at the same time removing from the garden landscape unsightly lines of red brick walls ; fifth,—for ornamental garden architecture, alcoves, grottoes, rock-work, &c. ; sixth,—for covering wooden shelving, in shops and warehouses, as a preservative from fire ; seventh,—for imitations of ancient wainscoting, and all other manner of carving in wood ; eighth,—as a ground for gilding, possessing advantages over every other in use ; ninth,—as a ground for decorative painting in fresco, *tecco-tempora*, and encaustic ; and a new style peculiar to itself, and more rapid in execution than any now in use ; tenth,—for making casts and models of all natural forms, even of landscapes ; eleventh,—for making tessellated pavements, and ornamental tiles ; twelfth,—as paint for ceilings and walls ; thirteenth,—for all domestic uses to which marble is at present applied ; as baths, wash-hand stands, plinths and pedestals, mantel-pieces, hearths, and sides of grates ; fourteenth,—for making moulds for various purposes, particularly for ornaments

formed of itself; fifteenth,—for making artificial globes; sixteenth,—for all purposes to which putty is at present applied, and a great variety of other useful and ornamental purposes. It may likewise be remarked, that it will set under water.—[*Inrolled in the Petty Bag Office, April, 1844.*]

Specification drawn by Messrs. Newton and Son.

To JOHN WINTER WALTER, of Stoke-under-Ham, in the county of Somerset, glove-manufacturer, for improvements in the manufacture of gloves.—[Sealed 16th May, 1843.]

THESE improvements in the manufacture of gloves are five in number.

The first improvement consists in forming gloves of leather or other suitable material, so as to dispense with the pieces or fittings termed “fourchettes” and “quirks.” In Plate VI., fig. 1, represents a shape for a glove, by cutting out according to which, the inside of the four fingers, and also the back of the little-finger and fore-finger, are produced in one piece; two more pieces (similar to that seen at fig. 2,) for the back of the other two fingers, being only required to complete the glove: the dotted lines shew where the pieces, which act as substitutes for the ordinary fourchettes and quirks, are folded. Fig. 3, shews the back of a finished glove. When the two pieces, of the kind represented at fig. 2, are inserted into the back of the glove, as above mentioned, the side-seams appear on the inside of the hand; but, by making a trifling alteration in the shape of the finger-pieces, they may be inserted in the inside of the hand, and the seams will then appear at the back of the glove.

The second improvement consists in a method of cutting out the thumb-pieces of gloves, in order that “under-tongues” may not be required. A thumb-piece, formed on this plan, is shewn, open, at fig. 4, and folded, at fig. 5; the parts cut by the dotted lines represent the additional quantity of material left to supply the room usually given by the under-tongue.

The third improvement relates to gloves which are intended to be made with fourchettes; and consists in forming each

fouchette of an angular shape, and in one piece, as at fig. 6, for the purpose of rendering quirks unnecessary. Fig. 7, represents the ordinary method of forming fourchettes, to which quirks are generally added; and fig. 8, another common mode of forming fourchettes, in which the two edges *a, a*, are united by sewing.

The fourth part of this invention consists in a peculiar construction of apparatus, or "index," to facilitate the sewing of gloves with a stitch called "pique," or backstitch. It is represented in perspective at fig. 9; and consists of a stationary jaw *b*, fixed on the top of a pedestal or support *c*, and of a moveable jaw *d*, which turns on a pivot at *e*; the jaw *d*, is kept closed by the spring *f*, and is opened by pressing on a treadle, connected by a rod *g*, with the arm *h*. The two parts of a glove which are to be sewn together, are placed within the jaws of the machine, with their edges overlapping, and the needle is passed through a small opening near the end of the jaw *d*, as will be more clearly understood by referring to the detached figs. 10, and 11: the position of the glove is shifted after every stitch. The advantage resulting from the use of this apparatus is, that the material being strained over the thin edge of the jaw *b*, at an acute angle, the needle passes more completely through both substances; whereas, in the ordinary mode of sewing pique work, the glove is held on the finger of the sewer, which, being an obtuse curve, the needle frequently passes through but one substance, and consequently the sewing is infirm.

The last improvement consists in a mode of fixing the thumb and other parts of a glove, by first sewing, and then felling them on the inside. It is described by the patentee in the following words:—"I cause the thumb of a glove, or any of the fittings of a glove, to be cut as if they were to be stitched into the glove, and then felled; but, in place of stitching them in, I cause the edge of the leather of the glove to be sewn to the thumb, in the parts heretofore stitched, thus producing round seams in place of stitched ones, and then I fell down the inner portion of the thumb; by which means I obtain the combination of round seams with felling, in place of a stitched seam with felling."

The patentee claims, Firstly,—the mode of forming or constructing gloves of leather or other suitable material, as described in respect to figs. 1, 2, and 3, by which fourchettes and quirks are dispensed with. Secondly,—the mode of shaping the thumb of gloves, made of leather, or of woollen cloth, as described in respect to figs. 4, and 5; thus dispensing with the use of under-tongues. Thirdly,—the mode of forming fourchettes of gloves, cut in an angular shape, in one piece of the material, as described in respect to fig. 6, which will give proper room to the fingers, without the use of quirks. Fourthly,—the mode of constructing a machine or index, for aiding the sewing of gloves with pique or back-stitch, as described in respect to fig. 9. Fifthly,—the combining of round sewn seams with felling, in affixing the thumb and fittings, as above described.—[*Inrolled in the Inrolment Office, November, 1843.*]

To FRANCIS PRIME WALKER, JUN., of Manchester, in the county of Lancaster, coal-merchant, for certain improvements in the manufacture of candles, candlesticks, or candle-holders, and in the apparatus connected therewith.—
[Sealed 9th May, 1842.]

THE first part of this invention consists in making mould candles of a cylindrical form, and mould and dip candles of an oval or any other oblong form, (in their cross section,) with three or more wicks, arranged parallel to each other, in a straight line across the diameter of the candle: the object of this improvement being to produce a more intense light than can be obtained from candles made in the ordinary manner. The moulds used by the patentee are shewn in Plate IV., fig. 1, being an elevation, partly in section, and fig. 2, a plan view of a mould for making cylindrical candles with three wicks; fig. 3, is an elevation, partly in section, and fig. 4, a plan view of a mould for making oval candles with three wicks. Dip candles are made, according to this invention, by placing together three or more partly-dipped wicks, and forming them into a candle, by dipping in the

ordinary manner. This improvement is also applicable to the manufacture of candles of any other form (in their cross section,) which may be found convenient, whether square, lozenge-shaped, or otherwise.

The improvements in candlesticks are three in number :— The first consists in forming a candlestick for holding three small candles, which are to be consumed at the same time ; it is represented, in partial section, at fig. 5 ; the candles are contained in three tubes *a, a, a*, within the hollow pillar of the candlestick, and are raised by means of the rods *b, b, b*, attached to the piece of metal *c*, from which a stud may project through the side of the candlestick. The second improvement consists in forming the interior of candlesticks of an oval form, to suit the oval candles before mentioned ; and in furnishing them with a means of retaining candles of different sizes, by the application of a piece of metal, (as shewn at *d*, in the transverse section, fig. 6, and plan view, fig. 7,) which is contained in a recess in the projection *e*, at the upper part of the socket, and is caused to protrude more or less therefrom by turning the screw *f*. The third improvement consists in a modification of the above holder, and is shewn, applied to a candlestick for holding cylindrical candles, in the transverse section, fig. 8, and plan view, fig. 9 : in this case, a handle *g*, is substituted for the screw *f*, and around its stem a spring is coiled, for the purpose of pressing the piece of metal *d*, against the candle.

The third part of this invention consists in an instrument to be inserted in the sockets of candlesticks, in order to retain the candles therein : it is shewn at fig. 10, and consists of two pieces of metal *h, i*, bent up and rivetted together : the upper piece *h*, receives the candle. The narrow part of these pieces, where the junction takes place, acts as a spring, and admits of the sides expanding, so as to suit candles and candlesticks of different diameters.

The last improvement relates to snuffing candles which have three or more wicks, and the three small candles which are used together, as before described ; it consists in curving the cutting edge or blade of the snuffers, in the manner represented at *j*, in fig. 11, so that the middle wick

may be snuffed shorter than the outside wicks, (as seen in fig. 5,) with the view of lessening the production of smoke.

The patentee claims, as his invention, the manufacture of candles with three or more wicks, arranged in the manner above mentioned; also the exclusive use, for the purposes of such manufacture, of the moulds hereinbefore shewn; and likewise the several improvements, herein described, in candlesticks or candle-holders, and in the apparatus connected therewith.—[*Inrolled in the Inrolment Office, May, 1842.*]

To SAMUEL DOBREE, of Putney, in the county of Surrey, Esquire, for certain improvements in the manufacture of fuel,—communicated to him by his son, Cartaret Priaulx Dobree, lately deceased.—[Sealed 17th February, 1844.]

THIS invention consists in a peculiar mode of mixing, by heat, coal dust, breeze, cinders, or similar matters, with pitch or other bituminous substances.

The apparatus employed by the patentee is a vessel of iron or other metal, surrounded by a steam jacket: both the vessel and its jacket are provided with a safety-valve, and with a man-hole at top and bottom, and there is a cock which opens into the jacket, to admit high-pressure steam from an adjacent boiler, and another cock at the bottom of the jacket, to discharge the water resulting from the condensation of the steam: a communication is also established between the vessel and its jacket, by means of a cock.

The coal dust, breeze, or cinders, are intimately mixed with the pitch or other bituminous substance, in any suitable proportions: those proportions which the patentee has used for steam fuel are, from 7-8ths to 11-12ths of coal dust, to from 1-8th to 1-12th of powdered pitch. Steam, of a pressure of 60 lb. on the square inch, is admitted from the boiler into the steam jacket; and when the inner vessel has become heated, the mixture is thrown in, and the man-hole closed. Steam is now admitted from the jacket into the inner vessel, until a pressure of about 6 lb. on the square inch is obtained within the latter; when the cock of communication between

the jacket and the inner vessel is closed, and the steam is allowed to escape freely from the inner vessel. The substances composing the mixture will then be found to be heated, the pitch or other bituminous matter melted or softened, and the entire mass so amalgamated, that the compound can be formed into small blocks or portions by pressure in moulds. The blocks of fuel are then placed in a hot closet, to evaporate any moisture they may contain, and render them fit for use.

The patentee claims, as his invention, "the process of heating mixtures of combustible matters and substances, in the proportions hereinbefore stated, or in any other suitable proportions, by high-pressure steam, generally; but more particularly in a double vessel, of such general form and construction, and of such subordinate arrangements, as hereinbefore described; and the conducting and aiding such process by the application to it of high-pressure steam: the particular geometrical form or figure of such vessels being such as shall be found suitable to the due performance of the said process, and convenient of construction in practice."—[*Inrolled in the Rolls Chapel Office, August, 1844.*]

To JULIUS SCHOTTLAENDER, of St. Swithin's-lane, in the city of London, merchant, for certain improvements in the deposition of metals upon various felted and other fabrics.—
[Sealed 8th December, 1843.]

THE first part of this invention consists in coating with metal, by electricity, various felted and other fabrics; such as cloth, linen, leather, paper, glass, earthenware, and similar non-conducting substances, by bringing the fabrics into contact with conducting surfaces.

The patentee illustrates his invention by describing the methods which he adopts for coating metals with copper; but any other metal may be used. A plate of copper (which the patentee terms a die or matrix) is coated on one side with varnish, or other suitable nonconducting material, and the other side is rubbed over with plumbago, to prevent the

adhesion of the metallic deposit. Upon that side of the plate which is covered with plumbago, the cloth to be coated with metal is placed, and secured by cementing or otherwise; and the matrix is then immersed in a solution of sulphate of copper, and connected with the zinc pole of a galvanic battery; another plate of copper being then immersed in the solution, and connected with the copper pole of the battery, the deposition of metal upon the matrix commences. When the surface of the matrix is covered with a thin film of copper, the depositing metal begins to penetrate the interstices of the cloth, and, if the operation is continued sufficiently long, will appear in small globules at the opposite side. As soon as the required thickness of metal has been deposited, the matrix is removed from the solution, and the cloth separated therefrom: the surface of the metallic coating will be either plain or ornamented, according as the surface of the matrix is prepared, whether plain, or ornamented with a raised or sunk pattern; and the metallic deposit may be afterwards gilt, plated, or otherwise improved in appearance.

Instead of using the copper plate alone, as above mentioned, the patentee sometimes employs, as a matrix, a plate of copper, together with a plate formed of an alloy of six parts lead to one of antimony; or, in lieu of this compound matrix, the copper plate may be used in connection with gold, silver, or lead, in the state of foil.

Long pieces of cloth are coated with copper by means of the apparatus represented in perspective at fig. 1, in Plate VI., *a*, is a wooden trough, containing a solution of sulphate of copper, in which is immersed a plain or engraved copper roller *b*, connected with the zinc pole of the battery; *c*, is a curved plate of copper, placed beneath the roller *b*, and connected with the copper pole of the battery. The cloth *d*, passes slowly over the roller *c*, under the roller *b*, and over the roller *f*; and, in proceeding through the solution, between the roller *b*, and plate *c*, it receives a deposit of copper, which will be either plain or ornamented, according to the surface of the roller *b*.

In some cases, the cloth may be operated upon by the apparatus represented at fig. 2, which is used without a

trough. *g*, is a copper roller similar to the roller *b*, before mentioned, and connected with the zinc pole of the battery; *h*, is another copper roller, connected with the copper pole of the battery, and furnished with a thick coating of felt or other fibrous material *i*; this felt is kept saturated with a solution of sulphate of copper, which is allowed to drop upon it from the cock *j*, of the vessel *k*, and the cloth *d*, passing slowly between the rollers, receives a deposit of copper.

If the cloth is not more than from twenty to thirty feet in length, the apparatus shewn at fig. 3, may be employed. *l, l*, are porous cylindrical vessels (made of unglazed earthenware or other suitable material), placed in a wooden trough *m*, containing a solution of sulphate of copper; these vessels *l*, are filled with a solution of common salt, or other exciting fluid, and in each a cylinder of zinc *n*, is placed; which cylinders are connected with each other, and with two copper plates *o, o*, in the manner shewn, so as to form a galvanic arrangement. The outer sides of the plates *o, o*, are rendered inactive, by the application of varnish, &c., and the inner sides are rubbed with plumbago, over which, as in the former instance, the cloth is fixed, and upon it a coat of metal is deposited.

Previous to operating upon woven or felted fabrics, the patentee prefers washing them over with a mixture of clay and water, about the consistence of cream; and, when dry, the clay is removed, by washing in clean water; some of the finer particles only of the clay remaining in the cloth. The object to be attained by this treatment, is, to increase the porous character of the fabric, counteract the effects of any grease that may be present, and facilitate the deposition of the metal, which filters through it; the clay also improves the character of the deposited metal, and may be used with advantage in all the processes of electro-plating and gilding.

When the fabric to be metallized is not sufficiently porous, such as leather, paper, &c., before being placed in contact with the matrix, its surface is coated with a paste of the metallic salt which is to be employed.

Glass, glazed earthenware, and similar substances, are prepared to receive a coating of metal by roughening their

surfaces, by mechanical or other means, such as grinding or etching; the article is then surrounded by a matrix of metal, or of unglazed earthenware, plaster of Paris, &c. (the matrix, when formed of nonconducting materials, being rendered conducting, by the application of plumbago), connected with the zinc pole of the battery, and immersed in the solution, together with a plate of copper, connected with the copper pole of the battery. The metal is deposited from the solution in the space between the matrix and the enclosed article, and a copy, in metal, of the design which has been employed, is thereby firmly fixed to the article: the process is facilitated by interposing between the article and the matrix, a paste of the metallic salt employed. If the surface of the glass, earthenware, &c., be made conducting, by the application of plumbago, foils, &c., the matrix, which is to give the design, may be a nonconductor, as plaster of Paris, cloth, lace, embossed paper, or other porous substance; but, in this case, the glass (and not the matrix) is to be connected with the zinc pole of the battery.

The internal appearance of transparent objects, such as glasses, may be much heightened by the application of gold or other metal, in the state of thin foil, which may be affixed to the glass by varnish or cement; on the external surface of the foil a metallic design (in copper, for instance) may be deposited, and afterwards gilt. Instead of foil, very fine wire may be wrapped round the glass, or it may be coated with fine wire gauze, upon which an ornamental design, in metal, may be deposited.

Brushes are made by the patentee, by binding a quantity of fine wire or bristles together, and placing them upright on a metallic plate, in a solution of a salt of copper, in connection with a galvanic battery; the copper deposit envelopes and binds together the wires or bristles, to a height depending upon the length of time the process is allowed to go on; thereby forming a brush of great durability.

The second part of this invention consists in three improved batteries, or apparatus, for effecting the deposition of metals from their solutions by electric agency.

The first is called the concentric battery, and consists of a

cylinder of zinc, open at each end ; in this is put a cylindrical vessel of unglazed earthenware, open at the top, and in it a cylinder of copper ; in the copper cylinder another of earthenware is inserted, and then one of zinc, and so on until the interior is filled ; the copper and zinc vessels being placed alternately, with a cylinder of earthenware between them.

The second battery is termed the mercurial battery ; it consists of alternate series of copper and mercury, separated by porous diaphragms, and immersed in a solution of sulphate of copper.

The third is called the magnetic battery ; it consists of two circular arrangements of horse-shoe magnets, placed one within the other ; the outer circle being enveloped with copper wire, covered with silk, between the two ends of which wire, when the battery is in action, an electric current is transmitted. When the poles of the inner circle of magnets stand opposite the contrary poles of the outer circle (as in the diagram, fig. 4), no electricity passes ; but on moving the inner circle round, so as to bring similar poles in opposition, (as in fig. 5), a current of electricity passes through the wire coil. Thus, on communicating a rapid motion to the inner circle, a rapidly intermitting flow of electricity will pass off from one wire to the other ; its intensity being proportioned to the number and size of the magnets, the length of the covered wire, and the speed at which the magnetic circle revolves.

The patentee claims, Firstly,—the methods, hereinbefore described, for coating the surfaces of cloth, linen, leather, paper, glass, earthenware, and other such-like nonconducting substances, by the electric deposition of metals between the said surfaces and a suitable die or matrix ; by which means either plain or figured surfaces can be produced at pleasure. Secondly,—the apparatus, hereinbefore described (and shewn in figs. 1, 2, and 3), for conducting certain of the foregoing processes. And, Thirdly,—the three forms of battery hereinbefore described, namely, the concentric battery, the mercurial battery, and the magnetic battery.—[*Inrolled in the Inrolment Office, June, 1844.*]

To WILLIAM SHEPHERD, of Kingston-upon-Hull, joiner and builder, for an improved four-port slide-valve, and an improved controller for reversing steam-engines, and for working the steam expansively in the cylinder.—[Scaled 18th November, 1843.]

THIS invention consists, firstly,—in a slide-valve with four ports, that is to say, an induction-port and eduction-port at each end of the cylinder; each pair being regulated by its own D-slide, or its own portion of a double D-slide valve, as hereinafter described, to shut off the steam at the extremities of the cylinder; secondly,—in securing the working D-valves upon the valve-rod, by a right and left-handed screw, so that, by turning the valve-rod, the valves can be removed further from each other, and thus cut off the steam at an earlier period of the stroke; thirdly,—in an arrangement of valves, termed a controller, for effecting the immediate reversion of steam-engines; which may also be used for working the steam expansively.

In Plate IV., fig. 1, is a vertical section, and fig. 2, a horizontal section (on the line A, B, of fig. 1,) of the cylinder of a steam-engine, with these improvements applied thereto; fig. 3, is an external view of the valve-casing, with the induction and eduction-pipes. *a, a¹*, is the four-port valve, which alternately opens and closes the communication between the steam-ports *b, c*, the interior of the valve-case *d*, and the passage *e*, which leads either to the induction or eduction-pipe, according as the engine is going forward or backward; the back of the parts *a*, and *a¹*, work against the packing *f*, and the distance between those parts is increased or diminished by turning the valve-rod *g*, on which a right and a left-handed screw is formed, as shewn. *h*, is the induction, and *i*, the eduction-pipe; in each pipe is a hollow cylinder or valve *j*, with one or more steam-ways cut in it, which, with its gearing, constitutes the controller; the object being to open a communication between the interior of the valve and the passages leading to the valve-case. Supposing the piston to be moving in the direction shewn by the arrow

(fig. 1), the engine is moving forward; then, if the engine is to be reversed, the valves j, j , are to be turned simultaneously, till the opening in the valve of the induction-pipe h , shall communicate with the passage e , instead of the passage or opening k , and the opening in the valve of the eduction-pipe i , with the opening l , instead of the passage e ; thus the steam, instead of passing through the opening k , into the valve-case, and thence into the upper part of the cylinder, forcing the piston downwards, will be turned into the passage e , and, passing into the lower part of the cylinder, force the piston upwards, reversing the motion of the engine.

Fig. 4, is a vertical section; fig. 5, a horizontal section (on the line c, d , of fig. 4); and fig. 6, an external view of an arrangement of apparatus for reversing the engine by means of a controller, as above described, in which a common marine-engine valve is employed, instead of the four-port slide-valve; the same letters of reference being used for similar parts as in the preceding figures. The induction-pipe h , opens into the passage e , communicating with the middle portion of the valve-case d ; and the eduction-pipe i , opens into the passage m , which communicates with the top of the valve-case; or it might communicate with the bottom of the case, if preferred. The middle portion of the case d , is separated from the top and bottom by two semicircular packings f, f , which press against the D-valve n ; and the top and bottom of the case communicate by means of the hollow space in the valve. The steam passes from the induction-pipe through the passage e , and the space around the valve, and into the cylinder at the port c , forcing the piston upwards; if the engine is to be reversed, the two valves j, j , are to be turned, until the induction-pipe opens into the passage m , and the eduction into the passage e ; by which means the steam will be caused to pass along the passage m , into the upper part of the valve-case, and thence into the cylinder through the port b , thereby reversing the motion of the piston. In this combination, the steam could be cut off at any part of the stroke, by turning the valve in the induction-pipe by any suitable gearing.

Fig. 7, is a vertical section; fig. 8, a horizontal section (on

the line E, F, of fig. 7); and fig. 9, a vertical section (on the line G, H, of fig. 7), of an arrangement for working with the four-port slide-valve and controller; the various moving parts of the valves consisting of pistons and piston-rods, being distinguished by the same letters as used in the preceding figures.—[Inrolled in the Rolls Chapel Office, May, 1844.]

To WILLIAM NICHOL, of Edinburgh, lithographer and printer, for improvements in lithographic and other printing presses.—[Scaled 16th January, 1844.]

THIS invention of improvements in lithographic and other printing presses refers more particularly to those driven by steam or other power, and consists, firstly,—in the application thereto of a self-acting presser-bar, which is brought to act upon the tympan, and produce the required impression; secondly,—in the application of a reversing motion to lithographic and other presses, by which they are more advantageously adapted to be worked by steam or other power; thirdly,—in a novel construction and arrangement of the parts of a press, by which the operation of printing may be performed at each end of the press alternately; thus obviating the necessity of drawing back the tympan-frame and carriage after each impression, and consequently effecting a saving of time and labour; fourthly,—in the application of an elastic presser or scraper, in place of the ordinary comparatively rigid wooden scraper; and fifthly,—in the use of a self-acting apparatus for lifting and lowering the tympan-frame.

In Plate VI., fig. 1, is an end view; fig. 2, a side view; and fig. 3, a plan view of a press, constructed so as to embody the first and second parts of this invention. *a, a*, is the frame-work; *b, b*, standards for supporting the upper parts of the press; and *c*, a cylinder, with pins fitted around its periphery, which enter corresponding holes in the under surface of the carriage *d*, so as to move it forward by a kind of rack-and-pinion motion. *e*, is a wheel, in which moveable cogs or teeth are inserted, in the way represented; and upon it is fixed the turning-plate *f*, for reversing its motion when

the impression has been completed. *g*, is a pinion, taking into the cogs or teeth of this wheel; *h*, a driving-pulley, revolving on the end of the pinion-shaft; *i*, a clutch, sliding upon a feather formed on this shaft, and thrown into and out of gear with the driving-pulley by a lever *j*. *k*, is a cross-head, firmly secured to the top of the standards *b, b*; *l*, a bar, capable of being raised or lowered by a vertical screw, working through the cross-head; *m*, the presser-bar, jointed to the bar *l*, and capable of moving in the direction shewn by dots in fig. 2; to this bar, either a scraper or roller may be affixed, for the purpose of pressing upon the tympan *n*; but, for lithographic printing, the former is preferred. *o*, is a bent lever, also jointed to the bar *l*, with a weight *p*, at one end of it, which causes its other end to press against the bar *m*, and keep it in the position shewn in fig. 2, when the press is out of action. *q*, is a lifter, placed immediately behind the part at which the tympan-frame is jointed to the carriage; and *r*, is a lithographic stone.

The operation of the press is as follows:—In the first instance, a sufficient number of cogs or teeth are inserted in the wheel *e*, to enable it, by means of the cylinder *c*, to carry the carriage *d*, such a distance under and beyond the scraper or roller on the presser-bar *m*, as will ensure a good impression from the stone or plate, placed upon the carriage. This being determined by passing the carriage once through the press, the turning plate *f*, is fixed at the end of the cogs, so that the pinion *g*, working outside the cogs, and arriving at the last cog, may be guided round by the turning plate, and made to act upon the inside of the cogs; by which means the motion of the wheel *e*, will become reversed (this is merely an application of the ordinary mangle motion); the pinion-shaft being mounted in a slot, so as to be capable of sliding a short distance, to allow of the pinion passing in the direction just described. The stone or plate being now laid upon the carriage *d*, and the tympan brought down, the workman throws the clutch into gear with the driving-pulley, by means of the lever *j*; and the pinion *g*, being thus caused to revolve, will communicate motion, through the wheel *e*, and cylinder *c*, to the carriage *d*, and carry it towards

the presser-bar *m*. The lifter *g*, now coming under the roller *s*, on the lower end of the lever *o*, will raise that lever into the position shewn by dots in fig. 2, and allow the presser-bar *m*, to assume a vertical position; the bar *m*, is prevented from being carried beyond this point, by its flanges coming against the standards *b, b*; and it will be evident that, in this position, the full amount of pressure will be exerted upon the tympan by the scraper or roller affixed to the bar. The carriage *d*, having moved on until the whole surface to be printed has passed under the scraper or roller, the turning-plate *f*, on the wheel *e*, is reached; the returning motion of the carriage instantly removes the pressure, by throwing the bar *m*, into its former position; and this bar, as soon as the lifter *g*, has passed from under the roller *s*, is kept in its place by the weighted lever *o*, falling into its original position. As soon as the carriage *d*, has arrived at the end of the return motion, the driving-pulley is thrown out of gear, by the end of the carriage, and the operation is complete.

Fig. 4, is an end view of a press, constructed so as to embody the third, fourth, and fifth improvements; fig. 5, a somewhat irregular vertical section; and fig. 6, a plan view, with the upper parts removed. This press being designed to act at both ends, all the moving parts are confined within the frame, that the workman may pass freely from one end to the other. *a, a*, is the ordinary cast-iron framework of the press, the side standards of which are firmly connected together by the cross-head *b*, at top, and by brackets and stretchers at bottom. *c*, is the scraper-bar, which can be raised or lowered by the adjusting screw *d*, and is guided in its vertical motion by grooves in the side standards. *e*, is the carriage for the stone or plate, which is made to traverse the press by means of a pinion *f*, acting upon a rack *g*, bolted to the under side of the carriage. The pinion *f*, is mounted upon a vertical shaft *h*, on the lower end of which is keyed a bevil-wheel *i*, driven by one or other of the bevil-pinions *j, k*, on the driving shaft *l*, as they are alternately thrown into and out of gear with the shaft, by the double clutch-box *m*, and lever *n*. The lever *n*, is composed of a horizontal arm, extending the whole

length of the press, and connected at the centre to an upright arm, the lower end of which is fixed upon an axle *o*; a short arm *p*, on this axle, works in the clutch-box *m*; so that when the horizontal arm of the lever is moved in either direction, the axle *o*, will be turned, and the clutch-box be caused to throw one of the pinions *j*, *k*, into gear with the shaft *l*. *q*, *q*, are rollers, on which the carriage *e*, travels; their axes working in bearings *r*, the centre part of which serves also as a socket for the vertical shaft *h*. There are four projections on the carriage, with square holes in them, to receive the parts *s*, which form sockets for the tympan-frame to rest in; the height at which the sockets *s*, are fixed, being regulated by pinching screws *t*. The tympan-frame *u*, is held together by two transverse bars *v*, *v*, which rest in the sockets *s*; their ends are enlarged to prevent any lateral movement of the frame, and to receive the screws *w*, for tightening the tympan. *x*, *x**, are two pair of friction rollers, upon the ends of the bars *v*, *v*, which rollers, by passing under the rail *6*, keep their respective end of the tympan-frame in the sockets. *y*, *y*, are double hooks, suspended loosely on pivots *z*, *z*; the lower ends of which hooks catch hold of the studs 1, 1, projecting from the tympan-frame, and raise the end of the frame, as the carriage *e*, advances from under it. 2, 2, are bars or stretchers, round which the tympan-leather 3, is fastened, and these bars are moved, when necessary, by the tightening screws *w*. 4, 4, are friction-rollers for keeping the carriage steady, in its backward and forward motion. 5, is a plate, which is fixed to the bar *c*, and employed instead of the usual scraper; it is made of steel, or other elastic metal, and fixed at an angle of 30° with the plane of the printing surface. The thickness or strength of the scraper is regulated by the distance at which it is fixed from the edge; if composed of steel, at a spring temper, about $\frac{1}{8}$ th of an inch is a suitable thickness, when held at a distance not exceeding one inch and three-quarters. (See fig. 7.) The edge of the presser or scraper 5, should be so formed, as to present to the surface of the tympan the same angle in one direction, as the length of the scraper does in the other, and then rounded, so as to prevent injury to the tympan. The object of giving this form to the

edge is, that the passage of the tympan, either to or fro, may have the same tendency to lift it from its surface, and thus uniformly call into play the elasticity of the metal in the production of each impression.

The action of this press is as follows:—The stone or plate, with the surface to receive the impression, being laid on the carriage *e*, the workman throws the pinion *j*, into gear with the shaft *l*; and by this means motion is communicated to the wheel *i*, and thence to the pinion *f*, and rack *g*, so as to move the carriage in the direction of the scraper *s*. As the carriage advances into the position shewn in fig. 5, with the tympan-frame, the raised end of that frame has a tendency to fall, but is prevented by the studs *1, 1*, coming within the forked ends of the double hooks *y, y*; and the end of the frame is gently lowered into the sockets *s, s*, by the time the rollers *x, x*, have passed from under the rail *6*. The hooks *y, y*, being liberated from the studs, have now assumed a vertical position, and remain so until, by the progress of the carriage and tympan under the presser or scraper, the studs *1*, 1**, advance into their forked ends, and carry them forward. The continued progress of the carriage and frame will soon have carried the hooks to the extremity of their range; and, as the former continues to advance (the rollers *x*, x**, being now confined under the rail *6*), the right-hand end of the tympan-frame will be lifted out of its sockets, and raised from the stone or plate, so as to leave it ready to be prepared for yielding another impression. When the carriage *e*, has advanced so far as to bring the parts into the position just described, it strikes against a projection on the end of the lever *n*, and, by carrying it forward, throws the pinion *j*, out of gear. The carriage will then remain stationary until the workman, by pulling the handle of the lever, shall throw the other pinion *k*, into gear; the carriage will then again pass under the presser or scraper, and the operation of printing will be repeated.

The patentee claims, Firstly,—the self-acting presser-bar, represented in figs. 1, 2, and 3, and marked *m*. Secondly,—the application of a reversing motion to lithographic or zincographic presses. Thirdly,—the general arrangement

and construction of the lithographic or zincographic press, represented at figs. 4, 5, and 6, admitting of the operation of printing at both ends. Fourthly,—the application of the elastic presser or scraper, marked 5. And, Fifthly,—the self-acting apparatus for lifting and lowering the tympan-frame, and marked *y, y*, in the drawing.—[*Inrolled in the Rolls Chapel Office, July, 1844.*]

To JAMES LINDLEY, of Cranbourne-street, in the county of Middlesex, Gent., for improvements in coffins.—[Sealed 16th January, 1844.]

THE object of this invention is to prevent the escape of any effluvia from coffins, and to prevent the spreading of epidemic diseases; and also, when required, to preserve bodies for a long period from decay.

In Plate IV., fig. 1, is a longitudinal section of one of the improved coffins, and fig. 2, a plan view of the interior. The coffin is made of any suitable wood, and the requisite bend is given to the sides by the agency of steam; the upper part is rabbetted to receive an inner lid *a*, in which is fixed a piece of glass, in order that the face of the deceased may be seen; or, if desired, a larger piece of glass may be fixed in the lid. The different parts are fastened together by screws and nails, and the joints are closed with putty, white lead, or India-rubber; the interior of the coffin is then covered with a cement, made of bees' wax and resin or pitch, by means of a hot iron, so as to render the coffin air-tight. The body is prevented from being mutilated, when removed from one place to another, by attaching it to the bottom of the coffin by the three straps *b, b, b*, one of which passes over the head, another across the breast, (under the arms,) and the third over the knees. The accumulated secretions of the body are drawn off through the stop-cock *c*, and tube *d*, into the air-tight can *e*: the cock *c*, is shewn in section, on an enlarged scale, at fig. 3; it is formed slightly tapering, with a screw on the outside, and has a groove *f*, in the top, to receive the screw-driver by which it is screwed into the bottom of the

coffin; it contains a valve *g*, formed with a female screw in its interior, (into which is inserted the nozzle *h*, of the tube *d*), and having a groove in its lower edge to receive the instrument used for opening and closing it. The mephitic gas, which is sometimes produced in such quantities as to burst the body, and even the coffin, is carried off through the stop-cock *i*, and tube *j*. If the coffin be made of lead, the soldering process will render the application of putty, white lead, or India-rubber, to the joints, quite unnecessary.

The body may be preserved for a long period, by placing chlorate of lime in perforated boxes *k*, placed at the head, foot, and sides of the coffin; or in a perforated case, fixed round the inside at the bottom; or by exhausting the air or gas by means of an air-pump, connected with the stop-cock *i*, and thus keeping the body in a vacuum.

For the sake of economy, instead of using velvet, cloth, or other stuffs, the patentee covers the coffin with flock, laid on with glue, India-rubber, gum, or other substances, and ornamented as usual.—[*Inrolled in the Inrolment Office, July, 1844.*]

To WILLIAM JOHN HAY, of Portsmouth, operative chemist, for improvements in producing light, by percussion, for signals and other purposes.—[Scaled 25th November, 1843.]

THE first part of this invention consists in igniting pyrotechnic preparations, for signals and other purposes, by means of a sliding rod or wire, applied to the cases containing the combustible materials.

In Plate VI., fig. 1, is a vertical section of the improved apparatus for igniting the pyrotechnic matter; fig. 2, is a plan view of the same; and fig. 3, represents the front of the case, before the apparatus for firing the charge is applied. The case *a*, is made of paper or other suitable material, and has a wooden partition *b*, fixed in it, directly under the charge; below this partition is placed the coiled end of a rod or wire *c*, which passes through the slot *d*, in the front of the case, and, ascending, enters the upper end of the case, above

the charge. The wire *c*, is protected by the hollow cover *e*, (shewn separately at fig. 4,) fastened to the case *a*, by thread or yarn *f*; and to prevent any accidental movement of the wire, a piece of paper is pasted over the upper part of the slot *d*. Upon the top of the case *a*, is a plate *g*, the flanged ends of which are bent downwards, and one of them enters the groove *h*, (fig. 4,) of the cover *e*, while around the other the thread *f*, is wound; in one end of the plate *g*, a slit is made, through which the wire *c*, passes, so as to come under the end of a spring *i*, fixed to the under side of the plate *g*, as shewn in fig. 5. The upper part of the case, between the charge and the plate *g*, is filled with cotton, impregnated with gunpowder; or, instead of this, the charge may be covered with a disc of pasteboard, through which pieces of quick-match have been introduced, in the manner represented in fig. 6. Between the spring *i*, and plate *g*, the percussion matter used for igniting the charge is placed; that preferred by the patentee consists of a small globule of glass, containing sulphuric acid, and surrounded by a mixture of chlorate of potassa and sugar, or other carbonaceous matter, over which a covering of paper is placed. The lower end of the case is closed by a bottom *j*, of pasteboard, shaped like the cover of a pill-box, and then over the whole of the instrument a paper covering is pasted. The charge is ignited by grasping the instrument firmly in the hand, and pressing it upon any hard substance that will enter into the lower end of the case, such as a stick, (by which the light may be afterwards held,) so as to move the wire *c*, and thus cause the percussion matter to explode.

The second improvement consists in a mode of applying percussion matter for igniting the charge in the case *a*, so as to protect the material from accidental discharge.

In this case, the wire *c*, plate *g*, and spring *i*, are dispensed with, as represented in the section, fig. 7; the percussion matter is attached to the bottom *j*, and a quick-match *l*, passes therefrom to the upper end of the case *a*; so that when the percussion matter is exploded, by the bottom *j*, being forced in, the match will communicate fire to the charge.

The patentee claims, Firstly,—the mode of arranging appa-

ratus for producing light, for signals and other purposes, whereby a sliding rod or wire is caused to discharge the material at the upper end of the case (the apparatus being securely covered, to prevent accidental ignition of the charge); and also the arrangement of spring apparatus for holding and discharging the percussion matter. Secondly,—the mode of forming the case *a*, divided into two compartments, one for the materials of the light, and the other for the percussion matter; so that by forcing a handle or stick into the end of the case *a*, the matter will be discharged in the manner above described with respect to fig. 7.—[*Inrolled in the Inrolment Office, May, 1844.*]

To ANTOINE FRANCOIS JEAN CLAUDET, of High Holborn, in the county of Middlesex, glass-merchant, for an invention of improvements in the process and means of obtaining the representation of objects of nature and art,—being a communication.—[Sealed 21st November, 1843.]

THESE improvements consist in rendering the Daguerreotype picture susceptible of producing, by printing, a great number of proofs or copies; thereby transforming it into a complete engraved plate.

The process is established upon the following facts, which have come to the knowledge of the inventor:—

1. A mixed acid, composed of water, nitric acid, nitrite of potassa, and common salt, in certain proportions, being poured upon a Daguerreotype picture, attacks the pure silver, forming a chloride of that metal, and does not affect the white parts, which are produced by the mercury; but this action does not continue long. Then, by a treatment with ammonia (ammonia containing already chloride of silver in solution, is preferable for this operation), the chloride of silver is dissolved, and washed off, and the metal being again in its naked state, or cleansed from the chloride, it can be attacked afresh by the same acid. This acid acts better warm than cold.

2. As all metallic surfaces are soon covered (when exposed to the atmosphere) with greasy or resinous matters, it is necessary, in order that the action of the acid upon the pure

silver should have its full effect, for the surface to be perfectly purified; this is effected by the employment of alcohol and caustic potash.

3. When a Daguerreotype picture is submitted to the effect of a boiling concentrated solution of caustic potash, before being attacked by the acid, the state of its surface is so modified that the acid spares or leaves, in the parts which it attacks, a great number of points, which form the grain of the engraving.

4. When the effect of the acid is not sufficient, or, in other words, if it has not bitten deep enough, the effect is increased by the following process:—Ink the plate as copper-plate printers do, but with a siccativ ink; when the ink is sufficiently dry, polish the white parts of the plate, and gild it by the electrotype process; then wash it with warm caustic potash, and bite in with an acid, which will not attack the gold, but only the metal in those parts which, having been protected by the ink, have not received the coating of gold. By these means the engraving is completed, as by the action of the acid alone it is not generally bitten in deep enough.

5. To protect the plate from the effects of wear, produced by the operation of printing, the following process is employed:—The surface of the plate is covered with a very thin coating of copper, by means of the electrotype process, before submitting it to the operation of printing; and when that pellicle or coating of copper begins to shew signs of wear, it must be removed altogether, by plunging the plate in ammonia, or in a weak acid, which, by electro-chemical action, will dissolve the copper, without affecting the metal under it; the plate is then coppered again, by the same means, and is then ready for producing a further number of impressions. This re-coating operation may be repeated as many times as may be required. The following is the description of the whole process, which is divided into two parts, consisting of a preparatory and finishing process:—

Preparatory Engraving.—For this operation, which is the most delicate, it is necessary to have, 1. A saturated solution of caustic potash. 2. Pure nitric acid at 36° of the areometer of Beaumé (spec. grav. 1·333). 3. A solution of

nitrite of potassa, composed of 100 parts of water and 5 parts of nitrite, by weight. 4. A solution of common salt, composed of water 100 parts, and salt 10 parts, by weight. 5. A weak solution of ammoniacal chloride of silver, with an excess of ammonia. The ammoniacal chloride of silver must be diluted with 15 or 20 parts of pure water. In the description of the process, this solution will be called ammoniacal chloride of silver. 6. A weak solution of ammonia, containing 4 or 5 thousandths of liquid ammonia. This solution will be called ammoniacal water. 7. A weak solution of caustic potash, containing 4 or 5 thousandths of the saturated solution, which will be called alkaline water. 8. A solution composed of water 4 parts, saturated solution of potash 2 parts, alcohol 1 part, all in volume. This solution will be called alcoholized potash. 9. Acidulated water, composed of water 100 parts, and nitric acid 2 parts, in volume. Besides, it is necessary to have three capsulæ or dishes, made of porcelain, large enough to contain the plate, and covered with an air-tight piece of ground plate-glass, and two or three more capsulæ, which do not require to be covered; two or three glass funnels, to wash the plate; and two or three glass holders, in the shape of a spoon or shovel, by which the plate is supported when put in and taken out of the solution, without touching it with the fingers.

The Daguerreotype plate is submitted to the engraving process, after having been washed in the hyposulphite of soda, and afterwards in distilled water.

First process for biting in or engraving the plate.—The following solutions must be put in the capsulæ, in sufficient quantity, so as to entirely cover the plate:—1. Acidulated water. 2. Alkaline water. 3. Alcoholized potash, in covered capsulæ. 4. Caustic potash, in covered capsulæ. 5. Distilled water.

The plate being put upon the glass holder or spoon, is plunged in the acidulated water, and agitated during a few seconds, then put into a glass funnel, and washed with distilled water. It is taken again with the glass spoon, and plunged in the capsula containing alcoholised potash. This capsula is covered with its glass cover, and then heated, by

means of a spirit-lamp, to about 144° Fahrenheit. The plate must remain in the capsula half an hour, during which the solution is heated now and then, and agitated. During that time the following acid solution, which will be called *normal acid*, must be prepared; it is composed as follows:—Water 600 parts, nitric acid 45 parts, solution of nitrite of potassa 12 parts, solution of common salt 45 parts. These proportions are in volume. The normal acid must be poured in a capsula, covered with its glass cover, and a sufficient quantity must be kept in the bottle.

When the plate has been immersed in the alcoholized potash during half an hour, it is taken out of the solution by means of the glass holder, and immediately plunged in the alkaline water, and agitated pretty strongly; from thence it is put in distilled water. (A)

This being done, the plate is plunged in the acidulated water, and moved about therein for a few seconds: it is then put into the normal acid. When the plate has been immersed a few seconds in the acid, it is taken out by means of the glass holder, taking care to keep it as much as possible covered with the solution, and it is immediately placed horizontally upon a stand, and as much acid as the plate can hold is poured upon it from the bottle; it is then heated with a spirit-lamp, but without attaining the boiling point. During this operation it is better to stir or move about the acid on the plate by pumping it, and ejecting it again, by means of a pipette or glass syringe; after two or three minutes the acid is thrown away, the plate is put in the glass funnel, and there well washed with water, and afterwards with distilled water. (B)

Then, without letting the plate dry, it is put upon the fingers of the left-hand, and with the right-hand some ammoniacal chloride of silver, which is moved about the surface by balancing the hand, is poured upon it; the solution is renewed until the chloride, formed by the action of the acid, is dissolved; the plate is then washed by pouring upon it a large quantity of ammoniacal water, and afterwards some distilled water. (C)

Without allowing the plate to dry, it is then put in the

caustic potash, and the capsula being placed upon the stand, the potash is heated up to the boiling point; it is then left to cool (D); and beginning again the operations described from A, to D, a second biting is obtained; and by repeating again the operations described in A, and B, a third biting is produced. The plate is then dried; in this state the black parts of the plate are filled with chloride of silver.

The plate is then polished until the white parts are perfectly pure and bright. This polishing is done with cotton and "ponce" (pumice stone); afterwards, the chloride of silver, filling the black parts, is cleansed by the means described in B, and C. The plate is dried, but before drying, it is well to rub the plate slightly with the finger, in order to take off from the black parts any remains of an insoluble body, which generally remains on it. The preparatory engraving is then finished, and the plate has the appearance of a very delicate aquatint engraved plate, not very deeply bitten in.

Nevertheless, if the operation has been well managed, and has been successful, it is deep enough to allow the printing of a considerable number of copies.

Note.—Sometimes, instead of treating the plate with the boiling potash in the capsula, a similar result may be obtained by placing the plate upon the stand, covering it with the solution, and heating it by means of a spirit lamp, until, by evaporation, the potash becomes in a state of ignited fusion. By this means the grain is finer, but the white parts are more liable to be attacked.

Last operation of biting in.—This operation requires some of the re-agents before named, and also,

1. A siccativè ink, made of linseed oil, rendered very siccativè by boiling it sufficiently with litharge; it may be thickened with calcined lamp-black.

2. An electrotype apparatus, and some solutions fit to gild, and copper the plate.

Means of operating.—The plate must be inked as copper-plate printers do, taking care to clean off the white parts more perfectly than usual; the plate is then to be placed in a room sufficiently warm, until the ink is well dried, which requires more or less time, according to the nature of the oil employed.

The drying of the oil may be hastened by heating the plate upon the stand with the lamp, but the slow process is more perfect and certain.

When the ink is well dried, the white parts are cleaned again, by polishing the plate with cotton and ponce, or any other polishing powder: a ball of cotton, or any other matter, covered with a thin piece of caoutchouc or skin, can be used for this purpose. When polished, the plate is ready to receive the electro-chemical coating of gold, which will protect the white parts.

Gilding.—The gilding is obtained by any of the various processes of electrotyping which are known. The only indispensable condition is, that the surface obtained by the precipitation must not be liable to be attacked by any weak acid; a solution answering this purpose is made of 10 parts (by weight) of ferrocyanide of potassium, 1 part of chloride of gold, and 1000 parts of water, used with a galvanic battery. During the gilding the plate must be turned in several positions, in order to regulate the metallic deposit. In some cases the gilding may be made more perfect, if the plate is covered with a thin coating of mercury before being put in the gilding solution.

When the plate is gilded, it must be treated with the boiling caustic potash, by the process already indicated for the preparatory engraving, in order to cleanse it from all the dried oil or ink, which fills the hollows. The plate is then washed and dried, and when the oil employed has been thickened with the lamp-black, the surface of the plate is rubbed with crumb of bread, in order to cleanse and take off the black remaining; then, the white parts being covered and protected by a varnish not liable to be attacked, and the black parts being uncovered and clean, the plate can be bitten in by aquafortis, according to the ordinary process used by engravers.

This operation must be done upon the stand, and not by immersing the plate in the solution.

Before this last biting-in, if the preparatory engraving has not succeeded well, and the plate still wants a sufficient grain, it can be given by the various processes of aquatint engraving.

Before submitting the plate to the operation of printing, in order to insure an unlimited number of copies, it is necessary, as before stated, to protect it by a slight coating of copper, which is obtained by the electrotype process; otherwise the printing would soon wear the plate. This coating must be kept very thin, lest the fineness of the engraving, and the polish of the white parts, should be destroyed. In this state the plate can be delivered to the printer.

After a certain number of impressions have been obtained, it will be perceived that the coating of copper is worn in some places: then, this coating must be removed, and a fresh one applied in its place. For this purpose, the plate must be purified and cleansed by warm potash, and plunged in a weak acid, composed as follows:—Water, 600 parts; nitric acid, 50 parts; nitrous acid of engravers, 5 parts; all in volume. This acid will dissolve the coating of copper, and the plate being coppered again, by the same means as before, may be again submitted to the operation of printing; and as nothing can prevent the success of a repetition of the same operation, any number of impressions may be obtained. The coating of copper can also be removed by caustic ammonia.

The Daguerreotype plate engraved by this process may be also reproduced and multiplied by the electrotype process, the same as any other engraved plate.

The essential points of this process, which constitute the present invention, consist,—

First,—in the discovery and employment of certain properties of a mixture composed of nitric acid, nitrous acid, and hydrochloric acid, in determined or fixed proportions. The two last-mentioned acids may be employed either in a free state, or combined with alkaline or other bases. This mixed acid has the property of biting the pure silver, which forms the black parts of the Daguerreotype picture, without attacking the white parts formed by the amalgam of mercury. The result of the action of the biting is, to form on the black parts of the picture an insoluble chloride of silver; and this chloride of silver, which, when formed, stops the action of the acid, is dissolved by ammonia, which allows the biting to continue.

Secondly,—in the discovery of certain properties of a warm solution of caustic potash, and in the employment of the said solution, by which the mercury forming the picture is better and deeper amalgamated with the silver under it, so that many imperceptible points of the amalgam are affected in such a manner that the acid has no action upon them.

Thirdly,—in the discovery and employment of a process which produces a grain favourable to the engraving, by which the biting on the plate is rendered deeper. This is effected by filling the parts engraved with a siccativ ink, or any other substance, and then gilding the plate by the electrotype process: the gold is not deposited on the parts protected by the ink. When the plate is gilded, the ink is cleansed by the caustic potash, and the plate may be submitted to the effect of an acid, which does not attack the coating of gold, but bites only on the silver in the parts already engraved by the first operation.

Fourthly,—in the employment of a process by which the plate is protected from the wear of the printing operation. This is effected by covering the plate, before printing, with a slight coating of copper, by the electrotype process, and when the coating begins to wear, by printing, it is removed by a weak acid, or by ammonia, which dissolves the copper without affecting the silver under it. The plate is coppered again, and after another printing, the same operation is repeated, so that a considerable number of copies may be printed without much injury to the engraving.—[*Inrolled in the Petty Bag Office, May, 1844.*]

Specification drawn by Messrs. Newton and Son.

To WILLIAM WRIGHT, of *Duke-street, St. James's, in the county of Middlesex, surgeon aurist, for certain improvements in rendering leather skins or hides impervious to wet, more flexible, and more durable.*—[Sealed 11th January, 1844.]

THIS invention consists in improving the quality of leather, by the use of certain compositions, distinguished by the in-

ventor as Nos. 1, 2, 3, and 4; the compositions No. 1, and 2, being applied to leather made from hides, and Nos. 3, and 4, to that made from skins.

The preparation of the compositions is conducted in the following manner:—Composition, No. 1.—Twenty-five gallons of linseed, rape, or neat's-foot oil, are reduced, by boiling, to twenty gallons. Then a quantity of fat is drawn, by gentle heat, out of the cellular membrane of a bullock, sheep, deer, or such-like animal, and, after being strained, is boiled in soft water for an hour; it is then strained again, and allowed to cool; all moisture being carefully abstracted from it by placing it in cakes upon cotton cloths. Forty pounds of this prepared fat, together with a like quantity of fresh bees' wax, are mixed with the oil above mentioned, which is kept at a temperature of 150° Fahr., until the bees' wax becomes thoroughly incorporated. Two pounds and a half of caoutchouc (India-rubber) are now sliced into small pieces, and dissolved in fifteen pints of rectified oil of turpentine, by means of a sand-bath, kept at 250° Fahr., and twelve pounds and a half of Burgundy pitch are dissolved in twenty pints of rectified oil of turpentine, by employing a sand-bath, heated to 200° Fahr.; these two mixtures, after being allowed to cool to 150° Fahr., are added to the oil, fat, and bees' wax, and kept stirred until cold.

Composition, No. 2.—The oil, fat, and bees' wax are, in the first place, combined together in the manner before described; then fifteen pounds of yellow rosin are dissolved in ten quarts of oil of turpentine, by means of a sand-bath, heated to 200° Fahr.; when this mixture has cooled to 150° Fahr., it is added to the oil, fat, and bees' wax, and the whole is stirred until cold.

Composition, No. 3.—From fifteen to twenty pounds of caoutchouc, sliced in small pieces, are dissolved in twenty gallons of purified cod or sperm oil, by the application thereto of a heat of from 200° to 250° Fahr.

Composition, No. 4.—From fifteen to twenty pounds of caoutchouc, sliced in small pieces, are immersed in as much rectified oil of turpentine as will just cover the same, and the mixture is caused to simmer, by heating it to 250° Fahr., until

the caoutchouc is thoroughly dissolved ; an addition is then made of twenty gallons of purified cod or sperm oil, at a temperature of 200° Fahr., which is maintained until the mixture becomes a smooth fluid mass ; after this the temperature is allowed to descend to 150° Fahr., and ten pounds of fresh bees' wax being then added, the whole is stirred until cold.

The composition, No. 1, is employed for hides that have been tanned with oak bark ; and No. 2, for those which have been otherwise tanned. The method of using either of these compositions is as follows :—The hides are placed in layers, or upright, side by side, in a tank or other vessel, into which the composition, heated to from 100° to 120° Fahr., is allowed to flow, until they are covered ; in about two or three hours the hides become saturated with the composition, and are then taken out, and exposed to a current of atmospheric air, at a medium temperature, until thoroughly dry. When the hides are found to require more pressure, or more effective treatment, hydraulic pressure may be employed in the process ; or they may be placed in an air-tight vessel, which is then wholly or partially exhausted of air, and the composition, heated to from 100° to 120° Fahr., is admitted.

In preparing leather made from skins, the composition No. 3, is used, when the leather is thin, and No. 4 when it is rather thick. The skins are placed upon metallic plates, kept at a heat of 100° Fahr., and the composition, heated to the same degree, is applied with large stiff brushes ; the process of saturation may also be performed by the rarefaction of the air contained in a room constructed for the purpose.

Manufactured articles of leather are kept from one to two hours in an apartment in which a temperature of from 100° to 120° Fahr. is maintained ; the skins by this means having become thoroughly warmed, they are removed, and submitted to one of the compositions before described, until saturated therewith ; they are then returned to the heated apartment, and subjected to the same temperature, until they are dried, which will, in general, be effected in the space of from half an hour to an hour.

The patentee claims, Firstly, as a part of his invention of

certain improvements in rendering leather skins or leather hides impervious to wet, more flexible, and more durable, the four compositions prepared and compounded as above. Secondly, as the other part of his invention, the combination and application of those compositions to leather skins and leather hides, as hereinbefore described.—[*Inrolled in the Rolls Chapel Office, July, 1844.*]

To ALONZO GRANDISON HULL, late of Clifford-street, Bond-street, in the county of Middlesex, but now of Upper Brook-street, in the same county, Doctor of Medicine, for improvements in manufacturing or improving fermented and distilled liquors.—[Scaled 27th October, 1843.]

THESE improvements consist in passing a current of electricity through a quantity of wine, spirits, beer, or other fermented or distilled liquors, by means of an electrical apparatus. The object of this process, is, to improve the quality of the liquor so operated upon, by perfecting the fermentation, and thereby giving to the liquor a property similar to that usually acquired by age, and likewise affording a means of separating the acetous part of the liquor from the general mass. The most convenient mode of effecting this object, is, by placing the liquor in a close glass or glazed earthen vessel, and inserting the poles of a galvanic battery into the liquor, by means of which a current of electricity is carried through the liquor.

The quantity and intensity of the electric fluid required, will depend on the quantity and condition of the liquor to be operated upon, and the state to which it is desired to be brought; consequently, the space of time during which the process should be continued, must depend upon the same conditions. As these circumstances will necessarily vary, in operating upon different matters, the patentee has considered it impossible to describe any defined scale of proportions; but he has given some general rules, by which operators may be guided. If, for instance, two gallons of new wine are to be acted on, the patentee employs an ordinary galvanic battery, made on the

principle proposed by Smee, with half a dozen pairs of plates, about six inches by two inches in area: one or two pairs of these plates are generally used, with a solution of one part of sulphuric acid to twelve of water; the poles are of platinum; the negative being made of fine wire, about 1-200th of an inch; and the positive a thin plate, one inch by three in area. In this case, the poles should be about six inches apart; the positive being entirely immersed in the fluid (which is put into a close vessel of glass), and the negative inserted only about half an inch into the fluid. By an apparatus prepared with these conditions, the operation upon the wine should be continued for about a week, the effect being watched from time to time; and should the presence of gas appear, at either pole, in any considerable quantity, it may be desirable to lessen the strength of the battery, by weakening the solution, until little or no gas is perceptible. The requisite time for continuing this operation upon the wine can only be known by tasting it, as different qualities of wine will necessarily require different quantities and intensities of electricity.

In order to improve wine in any large quantity, an apparatus proportionably increased in power will be required. Beer is to be operated upon in the same way; but it will be found that malt liquors, generally, will require the process to be continued for a less time. Spirituous liquors will sometimes need to be operated upon for a longer time; but, in all cases, the flavour of the liquor, (occasionally tasted), must guide the operator.

It will require considerable caution, in operating upon different liquors, to prevent their natural briskness from being destroyed; which would be the case if the intensity of the battery were too great. By increasing the surface of either pole of the battery, the intensity of the electric fluid, at that pole, will be diminished, and *vice versa*; and even sometimes the negative pole may be made to present the largest surface; and by bringing the poles closer together the effect will be increased. By the use of one pole of the battery only, the effect may be produced, but by a much slower process. The most acid condition of the liquor will always be at the positive pole, and from which any quantity may be drawn,

in case the acid should be too redundant to be mixed up with the mass.

The elements of this improved process or mode of operating upon fermented and distilled liquors, being thus set forth, the details of which must be varied according to the quantities and conditions of the liquors; the patentee desires it to be understood, that he does not intend to confine himself to the use of any particular construction or arrangement of electrical or galvanic apparatus, or to any definite time of operating upon the liquors, or to any precise dimensions of the conducting poles. But he claims the application of a current of electricity, passed through fermented or distilled liquors, by means of any suitable machine or apparatus, for the purpose of improving their condition, or giving them those qualities which have heretofore been wholly obtained by age, and allowing the acid portion of the liquor to be partially drawn off, if necessary.—*Inrolled in the Petty Bag Office, April, 1844.*]

Specification drawn by Messrs. Newton and Son.

To ANTOINE MERTENS, of the London Coffee-house, publisher, for improvements in the manufacture of plaited fabrics,—being a communication.—[Sealed 16th December, 1841.]

THIS invention consists in producing plaited fabrics, by weaving strands or threads of India-rubber into them, at such intervals apart, that, when acted on by the contracting property of the India-rubber, the fabric, between two adjacent strands, shall be of sufficient width to form a complete plait or fold.

The India-rubber strands are used in the extended and non-elastic state, and either covered or uncovered; but when uncovered strands are employed, the operator should cover them, in the act of weaving. The strands are introduced either amongst the warp threads or weft threads, or sometimes amongst both, leaving square intervals of fabric, so that, on the application of heat, the fabric will be plaited in squares.

The patentee claims the mode of manufacturing plaited fabrics, by causing India-rubber strands or yarns to be interwoven at distant intervals, and in such a manner, that the fabric will become plaited, when the elasticity is restored to the India-rubber, by heat.—[*Inrolled in the Inrolment Office, June, 1842.*]

To RICHARD KITSON, of *Cleckheaton*, card manufacturer, and JOHN GARTHWAITE, of *Leeds*, flax spinner, for certain improvements in wire cards, for carding cotton, wool, silk, flax, and other fibrous substances; and for producing tow and yarn from line and tow-yarn waste, which comes from the spinning-frames, commonly called "hard waste."
—[Scaled 27th February, 1844.]

THE first part of this invention consists in forming the back of wire cards of those descriptions of leather called sheep-skin, bazil, and roan-bazil, cemented to woven fabrics.

The leather preferred by the patentees is the light and dark brown bazil; and when its thickness is sufficient for the kind of wire card required, the proper fillets and sheets are made by cementing one thickness of such leather on to a strong woven fabric (by preference, linen), with the flesh side of the leather next the fabric: in setting the wire teeth, the crowns of the staples should come against the leather; and, when at work, the fabric should be upwards. In joining the edges of the leather, isinglass is employed; but, for cementing it to the linen or other fabric, a composition is used, which is formed by dissolving half a pound of Irish moss in six quarts of water (removing the stalks when the moss is dissolved), and then dissolving eight pounds of the best glue therein. In some cases, particularly when the leather is thin, a piece of woven fabric is cemented between two thicknesses of the leather, the flesh sides of both being inwards; and, in addition to this, a piece of fabric may be applied to the outer surface of one or both pieces of leather.

The second improvement relates to the waste fibres produced in the process of spinning yarn from flax and tow, and called "hard waste;" it consists in boiling such hard waste

in soap and water, and subjecting it to the action of machinery, in order to clean, unravel, and render the fibres of tow again suitable for spinning into yarn.

The fibres of the hard waste are first opened and unravelled, by means of a "devil;" they are then boiled in water, with soft soap, (in the proportion of two pounds of soap to one hundred-weight of hard waste), for four or five hours, and are afterwards passed between pressing-rollers, and dried. The fibres are next submitted to a breaker carding-engine, and then to a finishing carding-engine, the sliver from which is drawn through a screw-gill, and then passes to the roving and spinning-frames.

The patentees do not confine themselves to the use of the machines just referred to, as others, acting in a similar manner, might be employed. They claim, Firstly,—the mode, herein described, of manufacturing wire cards, by applying the above descriptions of leather, combined with woven fabrics, as the backs of such cards. Secondly,—the making of tow-yarn, by employing the tow obtained from line or tow-yarn waste, called hard waste, as herein described.—[*Inrolled in the Inrolment Office, August, 1844.*]

Scientific Notices.

REPORT OF TRANSACTIONS OF THE INSTITUTION OF CIVIL ENGINEERS.

(Continued from Vol. XXIV. p. 448.)

Description of a new system of trussed Girder of wrought and cast Iron for bridges.—By Francis Nash.

THE girders, which are described in this paper, are stated to have been much used recently in France. The structure consists of a series of isosceles triangles, whose sides are formed of flat wrought-iron bars, the ends abutting against each other, and being turned back outward, passing through and being supported by two or more rows of cast-iron transoms, (according to the required depth and strength,) which also prevent the wrought-iron bars from collapsing, or from spreading. Under this

system the compression is resisted by the cast-iron, and the tension by the wrought-iron; each material in the direction of its greatest strength.

When used to form a bridge, as many of the girders as are requisite are laid upon stone or timber piers, against which they do not exert any lateral force; a timber flooring is placed either upon the upper surface, or on either of the other rows of transoms, according to circumstances, and the planking is generally covered with asphalte.

The results of the experiments upon girders of various strength and bearing, as tried in Paris, by order of the Minister of Public Works, are given in detail; whence it appears that two girders of 32 feet bearing, 3 feet $2\frac{1}{2}$ inches in depth, with four rows of transoms, each weighing, of cast-iron 642 $\frac{1}{2}$ lbs., and wrought-iron 874 $\frac{1}{2}$ lbs., total 1517 lbs., being loaded in the centre with 8280 lbs. of pig-iron, deflected only 2-10ths of an inch.

After other trials upon girders of increasing dimensions, four girders were braced together in pairs, bearing a timber floor between them of 17 feet 9 inches wide, resting on the third row of transoms; the dimensions and weight of each girder being,—

Length	74	8	
Height	6	3	
Weight, cast-iron.	5355 lb.	}	10,200 lb.
,, wrought-iron	4845 ,,		

The floor was then weighted in the centre with a mass of dry stone, when the relative amounts of deflection were as under :—

Weight in lbs.	Deflection produced.	
	At 18 feet 6 inches from the end.	In the middle.
59,547	$\frac{5}{12}$ ths of an inch.	$\frac{7}{12}$ ths of an inch
81,602	$\frac{6}{12}$ ths „	$\frac{8}{12}$ ths „
103,657	$\frac{7}{12}$ ths „	$\frac{9}{12}$ ths „
105,863	$\frac{8}{12}$ ths „	1 inch.
123,506	$\frac{9}{12}$ ths „	$1\frac{1}{12}$ th of an inch.

The weight was afterwards increased to 136,739 lb., without producing any apparent difference; but the loading stones, which were of a soft porous nature, becoming saturated with rain, a further deflection of 2-12ths of an inch was observed; on the return of fine weather, as the stones became dry, the girders recovered their original deflection.

The load remained upon the girders twenty-five days, and upon

removal, was found not to have produced derangement of any part.

In order to ascertain the effect of concussion, a weight of 9924 lb. of iron in bars, was allowed to fall suddenly from a height of 3 feet upon the floor, which was much crushed; but no injury was sustained by the girders, and scarcely any vibration was felt.

The paper is illustrated by two detailed drawings.

Account of the building of the "Wellington" Bridge, over the river Aire, at Leeds. By John Timperley,

This bridge was erected from the designs, and under the direction, of the late John Rennie: it is situated on the line of road leading from Leeds towards Wortley and Armley, and spans the river Aire at a spot where it is 100 feet wide, and about 6 feet in depth; the banks rising to between 7 and 8 feet above the surface of the water.

The borings, which were made to the depth of 30 feet on each shore, to prove the ground, previously to commencing the construction, shewed the strata to consist of fine sand, and then sand and gravel, with thin layers of what was supposed to be stone, but was probably hard concreted gravel, such as was afterwards found in excavating for the foundations. That on the south bank was commenced in the middle of September, 1817. The upper part, for 6 or 7 feet in depth, was through fine soft sand; then came a bed of alluvial gravel, containing, at about 12 feet from the surface, black rotten wood, roots of trees, shells, bones, and horns of animals. The upper part of this gravel was coarse and open, but it gradually became finer and more compact, until it assumed the hardness of a concreted mass, resembling agglomerate, very like (except in colour) the Blackwall rock, which was taken up about forty years since, in deepening the entrance from the Thames to the East and West India Docks. Upon this stratum Mr. Rennie ordered the foundation to be placed, although it was not so deep, by 4 feet, as he had originally intended.

The coffer-dam, which was formed of a double row of piles of half timbers, from 15 to 18 feet in length, was then completed; the best earth that could be procured for the puddle was of so light a nature, that in high freshes the leakage became so considerable, as to render it advisable to allow the dam to fill with water, to prevent its blowing up. The details of the construction of this coffer are given. It was kept dry by a steam-engine of 6 horses' power, which was fixed on the shore, and worked the pumps by an endless chain. The quantity of water was such as to keep the pumps constantly at work, night and day. The coffer-dam for the north bank was constructed after the foundations on the south shore were finished.

The details are then given of the sheet piling and wales, &c., in front of the abutments, which are each 30 feet long by 28 feet wide at the bottom, diminishing by offsets to 27 feet in length by 21 feet in width, at the springing of the arch.

The abutments are built in radiating courses within, but on the faces they are horizontal: the stones were from 14 to 18 inches thick, cut correctly from templates, made to suit the respective courses. The lowest foundation courses were of large blocks, laid dry, and the joints well grouted: but the other courses, up to the ordinary water-line, were laid in mortar made from magnesian limestone, got on the banks of the Aire, a few miles above Ferry-bridge: the proportions were, one part of lime, one part of clean sharp river-sand, and one part of forge scale, the whole well mixed and tempered, and used quite hot. The grout was made from the same lime, and was used for all the courses, except the lowest, where Parker's cement was employed, which was also used for pointing all the face joints up as high as the water-level. In the other parts of the structure, the mortar was composed of one part of lime to two parts of sand, but that for the arch was made of equal proportions of lime and sand.

Great care is stated to have been taken with the joints, as no underpinning was allowed, the beds of the stones being all dressed to coincide accurately. The ordinary allowance was $\frac{1}{4}$ th of an inch for each joint, but on trying the first fourteen courses, from the springing, it was found, that 1 inch only was taken up by the joints, which gave 1-14th of an inch for each.

The stones were laid on the south side by a moveable crane, and on the north side from the end of the two-wheeled truck, (somewhat resembling a timber carriage,) by which they were brought from the stone yard on the south bank, along a wooden tramway and temporary bridge, extending from the south to the north shore, using either a simple sling, or sheave-blocks, for placing the stones, according to their dimensions and weight.

The construction, dimensions, and cost of this truck and of the crane are given in detail.

The abutments being finished, the piles were driven, to support the centres, which were fixed so high as to be above the freshes. The lagging was laid 5 inches higher than the proposed arch, to allow for its settlement. The six centres were framed of Memel pine, each rib containing about 370 cubic feet of timber.

The striking-wedges were of seasoned oak, well greased; they were 6 inches wide and 9 inches in height altogether, the middle one, which was the largest, being the striking wedge. They were, however, found to be too narrow, for they were squeezed upwards of an inch into the timber, by the weight of the centres and the masonry.

Prior to framing the centres, one-half of the arch, which is a

segment of a circle of 91 feet radius, with a versed sine of 15 feet, was laid down, full size, upon a platform, from which templates were made, for dressing the voussoirs and arch-stones: the front voussoirs were 7 feet on the bed, at the springing, diminishing to 4 feet at the crown; but the interior arch-stones, near the springing, were much wider. The arch-stones were on an average 3 feet long, by 18 inches thick. It was customary, in setting the stones, to saturate them with water; a thin coat of mortar was laid on the under stone; the upper one was lowered, and well beaten down while the mortar was soft; the surfaces were thus brought closely in contact with each other, and any interstices that remained were grouted, after the vertical joints had been pointed with cement.

When the arch was turned to the extent of one-third from each side, about 20 tons of stones were piled on the crown, as an equipoise for the centres, and the haunches were not loaded until the key-stones were placed.

The turning of the arch occupied four weeks; when that was finished, the haunches were completed, and the centres were eased; but it was found that the weight, which before the arch was keyed was equal to 1000 tons, had forced the wedges into the timber, so as to render it necessary to cut some of them out, which occupied three days for the first easing. A second easing took place two days after, and after a third easing the centres were removed.

During the progress of the work, the arch squeezed down about $2\frac{1}{2}$ inches; in a few days after the centres were struck, it settled $1\frac{1}{2}$ inch, which increased slowly to $2\frac{1}{2}$ inches, after which no further subsidence was observed. The arch had thus arrived at the exact dimensions which were proposed by Mr. Rennie.

An account is then given of the progress of the remainder of the structure, the forming of the parapet, the roadway, the approaches, &c., the whole of which were finished on the 18th of June, 1819, having occupied thirty-three months in construction.

The stone used in the bridge is a brown coarse sandstone, or mill-stone grit, of great durability, from the quarries at Bramley-fall, about four miles from the bridge; they were brought down by water to within 120 yards of the work. The price of the stone in the vessel alongside the work, scappled ready for dressing, was 9*d.* per cubic foot; the dressing and setting, exclusive of the cornice and the parapet, cost $4\frac{1}{2}$ *d.* per cubic foot, which, with conveyance and mortar, made in the whole 15*d.* per cubic foot; the cost of the cornice and parapet walls was about 4*d.* per cubic foot extra.

The total quantity of masonry was 80,000 cubic feet, and the entire cost of the bridge, including the toll-house, was £7530.

The paper is illustrated by three drawings, shewing the plan, elevation, and longitudinal and transverse sections of the bridge, with the details of the masonry and the centering.

Mr. Rennie concurred in the accuracy of the description of the "Wellington" bridge; it presented an excellent example of theory and practice, not only on account of its strict conformity with the principles of equilibrium, but from the correctness with which the works had been executed, as was evinced by the small subsidence of the arch after the centres were struck.

Respecting the theory of the arch, writers were nearly agreed upon the principles established by de la Hire, upon the equilibrium of a loaded chain, or of a series of voussoirs, or wedges, with polished touching surfaces, as shewn in his "*Traité de Mécanique*," in 1695. The subject had been variously demonstrated by writers, but with little effect; architects were forced to select examples at random, for which no precise rules existed; but any person, on examining the actual state of an equilibrated arch of solid materials, or of a substantial chain suspended at its extremities by points, would immediately perceive the difference in the curves, or loads on the extrados, arising from the want of sensibility in the arch, or in other words, from friction and adhesion. Hitherto theory had been unable to comprehend these retarding forces, which had actually been so serviceable to the architect: Perronet was perhaps the first to throw any real light upon the subject: the experiments which he undertook, on the absolute strength of materials, in the year 1758, previously to the commencement of the celebrated bridge of Neuilly, and subsequently those by Gauthey, on the failure of the piers of the church of St. Geneviève, at Paris, were very instrumental in the advancement of the art. It was, however, chiefly owing to the good quality of the material, that Perronet was enabled to surmount the difficulties which arose from the unusual subsidence of the arches, in the bridge of Neuilly. The splaying of the arches, by which a double curvature was given to them, and which had been injudiciously copied in this country, was justified neither by science nor practice. The results of the French experiments were much too slow in reaching this country, and the strength of building materials was but little attended to, until within a recent period.

In the year 1824, the late Dr. Thomas Young, having engaged to contribute the article "Bridge," to the Supplement of the sixth edition of the *Encyclopædia Britannica*, applied to Mr. Rennie, to furnish the particulars of the Waterloo and Southwark bridges, then just completed; when, finding the data insufficient, Mr. Rennie undertook a series of experiments on the absolute and relative strength of materials, part of which he communicated to Dr. Young, and he subsequently published the whole in the *Philosophical Transactions* for 1818. The results were then applied to the calculations, on the lateral thrust of the arches of those bridges, perhaps for the first time in this country, and which were more amply applied afterwards to bridges in general by Mr. Ware, and his tables of the relative boldness of brick,

stone, and iron bridges, were valuable accessions to our knowledge on this subject.

As regarded the friction of arches, Mr. Rennie found that the arch stones of Waterloo and New London bridges commenced gliding, or pressing upon the centres, at angles of from 33° to 34° ; he believed that soon after the adhesion of the mortar commenced, the centres would have very little pressure on them, even from stones at an angle of 45° .

As to the gliding of the arch stones at the haunches, from the pressure of the upper voussoirs, he had never seen an instance of it; but he had seen the haunches so much eased in the centres, by the lateral action exerted in driving the stones into the vertex of the arch, as to allow the lagging, or cross bearers above the ribs, to be taken out. This proved the correctness of the rotative system of voussoirs, as shewn by experiment.

With respect to adhesion, Mr. Rennie had seen its effect on broken arches of considerable magnitude, among the buildings of Rome, and also in the bridge of Alcantara, over the Tagus, where the centre arch, of nearly 100 feet span, had been blown up by the French, leaving the adjoining arches and piers, which were upwards of 90 feet in height, standing perfectly undisturbed.

With respect to the magnitude of arches, M. Perronet expressed himself confident that arches of 500 feet span could be safely executed. The bridge which he proposed to construct, over a branch of the Seine, at Melun, consisted of a segment of a circle of 400 feet. The experience he had derived from the length of the primitive radii of the arches of the bridge of Neuilly, and his experiments on the strength of materials, would appear to justify so bold an experiment.

Mr. Rennie was of opinion, that with our strong magnesian limestones and hard granites, arches of larger span than any hitherto built, might be safely constructed.

There were numerous examples, both in ancient and modern times, of very large arches. The bridge of Narni, in Italy, of Vielle Brioude, in France*, and of Alcantara, in Spain, by the

* The following dimensions of the Pont de Brioude are given in a letter from M. Seguin to Mr. Rennie (dated Feb. 27, 1827). "The ancient bridge was constructed by the Romans for the use of foot-passengers, pack-mules, and small carts drawn by oxen."

	Metres.	English feet.
Length of the arch	56	= 183.73
Breadth "	5	= 16.005
Height "	18 to 19	= 59.058 to 61.339

"The arch was a segment of a circle, formed of volcanic stone, of little consistence. The bridge gave way in the course of time, but was upheld for fifteen years, by means of buttress walls, 6 metres (= 21.68 English feet) in thickness, and 10 metres (= 32.8 English feet) in height; and also by bars of iron, fixed in the wing wall, and through several courses of the arch-

ancients; and those of Gignac and of Castel Vecchio, by the middle ages; but the most remarkable example of cylindrical vaulting (the remains of which still existed), was the bridge of Trezzo, over the Adda, in the Milanese. The span was 251 feet over the chord, and 266 feet over the semicircle. The stone beams in the church of the Jesuits at Nîmes, and those between the towers of Lincoln Cathedral, the former equal to the segment of an arch of 565 feet span, and the latter to one of 252 feet span, proved how much could be done with materials of small dimensions.*

In modern times there were examples of bold vaulting in France, in the bridges of Neuilly, Mantes, St. Maixence, and Jena; in Italy, in the Ponte Sta. Trinita, Turin; in England and Wales, in the bridges of Llanrwst, of Pont-y-tu-Prydd, of Gloucester, of Chester, and those of London and Waterloo over the Thames; independently of numerous arches and viaducts, more recently erected for the use of railways.

The radii of curvature of the centre arch of New London bridge, taken near the vertex, would equal in boldness an arch of 333 feet; and the length of the key-stone, at 4 feet 9 inches, would make the depth only 1-70th of the whole span.

The origin of the arch had occasioned much controversy. The subject had been learnedly investigated by Dutens, Le Roy, King, and others, but apparently to little purpose, as the invention of the arch would now appear to be, with more justice, attributed to the Egyptians, as they seemed to have used it many centuries before the Christian era.

The researches of modern travellers, particularly those of Sir Gardiner Wilkinson, proved that the brick arch was known in Egypt in the reign of Amenoiph I., 1540 years B.C., and the stone arch in the time of Psamaticus II., 600 years B.C. "The most remarkable," says Sir Gardiner Wilkinson, "are the doorways surrounding the tanks of Assassief, which are composed of two or more concentric semicircles of brick, as well constructed as at the present day; and all the bricks radiate to a common centre."

Mr. Hoskins was of opinion that arches were constructed long anterior to the time of the Ptolemies; for in the pyramids of

stones. The structure finally fell, and a new stone bridge has been erected upon the same site, of which the following are the dimensions.

	English feet
Opening of the arch, (which is a semicircle)	150.91
Breadth of ditto	247
Height from the stream to the pavement	83.7

* Robinson, in his 'Travels in Palestine, mentions the remains of an arch over the valley of Kedron, at Jerusalem, supposed to have been 360 feet span.

Gebel, Birkel, and Dunkalie, which were of more ancient date, both round and pointed stone arches were discovered. Mr. Perring stated that he found at Thebes some remarkably well-formed arches of 12 feet to 14 feet span, built in concentric half-brick rings, the bricks of which were marked with the name of Sesostris; consequently they were upwards of 3180 years old.

A representation of the tomb of Saqqara and its arched vault of stone, was given in the vignette of the 10th chapter of the 3rd volume of Sir Gardiner Wilkinson's 'Manners and Customs of the Ancient Egyptians.'

The arch seemed to have been known to the Etruscans; and from the representations of their palaces and their sea-ports, the arch appeared generally to have been employed for moles and jetties.

With reference to the knowledge of the arch among the Greeks, opinions were very contradictory. The researches of modern travellers had brought to light many curious remains of Cyclopean or Pelasgic architecture; but, in confirming the descriptions of the ancient cities of Mycenæ and Orchomenos, they had left us still in ignorance as to their actual knowledge of the arch.

Mr. Rennie exhibited a series of lithographic prints, from drawings made by the late Mr. Dodwell during his travels in Greece. They displayed the various doorways of Pelasgic fortifications, from the lintel of single stones resting on upright jambs, to the overlapping of the stones until they reached each other, in the form of a triangle, as in the Gate of the Lions, the entrance into the Treasury of Atreus, &c.

But the most remarkable monument was the subterranean chamber, of which Mr. Dodwell's lithographic plate gave an imperfect idea; complete plans and sections of that extraordinary building were given by Mr. Donaldson in the supplement to the 'Antiquities of Athens;' from which it appeared to have been constructed in the form of a parabolic cone, of 48 feet in diameter at the base, and 44 feet 6 inches in height, by means of rings of regular masonry, overlapping each other until they reached the apex, where the aperture was closed by a flat stone. From this and other buildings of a similar kind, there was reason to infer that the ancient Greeks had very imperfect notions of the arch.

Mr. Kinnaird, in his 'Description of the Antiquities of Delos,' gave a representation of a portal or gateway on the ascent of Mount Cynthus, formed to support the wall of the ancient fortifications. The entrance was constructed with ten large stones, inclined to each other, like those at the aperture into the great Egyptian pyramid. It was perhaps the earliest specimen of Pelasgic architecture in Greece, displaying the first step towards the principle of the arch.

That it was known by the Etruscans seemed evident, from the remains of arches and bridges now existing in that country of the

Volsci in Italy; and the researches of travellers in that country, within the last few years, had brought to light many curious examples, anterior to the period of the Cloacæ of Rome, and the tunnel of Albano by Ancus Martius.

Mr. Rennie was of opinion, from his examination of the subject, that there existed no sufficient evidence to establish the knowledge or use of the arch among the Greeks.

Mr. Page presented two sketches, made by him, of two arches at Cape Crio (Cnidus, Rhodes). These arches were semicircular, built of large stones regularly radiating from a centre, without any mortar in the joints, and stood among Cyclopean remains, of which they apparently formed a part. He was of opinion, that the Greeks were aware of the properties of the arch. They evidently appreciated its form, for it must have been noticed by all travellers, how frequently the flat lintels were cut out on the under side; several specimens of this existed in the sepulchral remains now in the British Museum. At Athens, he had noticed a very considerable excavation, of a regular arched form, through solid marble.

Mr. Rennie observed, that as more useful lessons were given by failures in construction than by records of successful undertakings, he had caused a large drawing to be made of the bridge of the Boveric at Liège, shewing its state at the time of the report upon it, by the commissioners appointed by the Belgian Government, when it was condemned, and was ordered to be reconstructed, at the cost of the contractor, which however had not yet been done.

The bridge, which was built of hard, compact magnesian limestone, consisted of five arches of 78 feet span each, with a versed sine of 8 feet, which was between 1-ninth and 1-tenth of the span. The form of the arch was that of a segment of a circle of 100 feet radius, the angle of the springing was therefore $46^{\circ} 45'$. The abutments, at either extremity, were of rubble masonry, and were very deficient in weight and dimensions.

The obvious consequence of this want of due proportion was, that the abutments gave way, all the arches sunk at their centres, many of the stones nearly falling out, several of them were fractured in both directions, serious dislocations occurred in each pier, above the springings of the arches, and also down upon the cutwaters; and, in spite of all attempts to remedy the defects, the bridge was condemned, and was taken down, although it had cost upwards of £25,000.

It was evident that these flat arches were not well proportioned, and that the abutments were insufficient to support their thrust. It appeared also, from the report of the Commission, (of which he presented an abstract, No. 672,) that sufficient attention had not been paid to the quality of the workmanship, or in the selection of the materials employed.

[To be continued.]

NEW METHOD OF CLEANSING METALLIC CLOTH,

MORE PARTICULARLY APPLICABLE TO DAVY'S SAFETY LAMP.

IT is well known that the metallic cloth which surrounds the flame of the lamps used in coal mines becomes very foul, in consequence of a mixture of oil, soot, and coal dust insinuating itself between the meshes thereof; and as this clogging up of the meshes of the fabric causes a great diminution in the intensity of the light, it is found necessary to cleanse the same very frequently. For this purpose, the metallic cloth is exposed to the action of fire, which decomposes the oil and coal, and only leaves between the meshes a powder, which is easily removed by means of a dry brush. It is, however, impossible to heat metallic cloth to the degree required for decomposing the oil and coal, without bringing the same in contact with the air; by which means, in consequence of the oxidation of the iron, the wire is diminished in thickness, and the strength of the fabric consequently impaired.

Moreover, when the coal is of a sulphurous nature (as is often the case), the sulphur contained therein, being very destructive to iron, always renders the wire more liable to break. The consequence of this is, that the safety-cover, becoming thinner and more fragile, is much more likely to break from a shock, or even by the action of the flame; and thus the probability of accidents, which are of such frequent occurrence in mines, is greatly increased.

The following method of cleansing these kinds of fabrics entirely obviates the above-mentioned inconveniences:—Take a given quantity of carbonate of soda of commerce (which may be procured at a very low price), and dissolve it in water in a cast-iron vessel. To this solution is to be added a sufficient quantity of quick-lime, to deprive the carbonate of soda of the carbonic acid contained therein. The quantity of lime may be easily calculated by means of a table of chemical formulæ.

By sufficient boiling, a perfect re-action is produced; the carbonic acid combines with the lime, and forms an insoluble carbonate, and the soda becomes caustic. It is only necessary to separate the carbonate of lime from the caustic soda by filtration. In this solution of caustic soda, which is diluted more or less, according to circumstances, the foul metallic fabric is to be immersed. After remaining a short time (a few minutes will suffice) in this boiling liquid, the oil deposited in the meshes will be converted into soap, and the soot and coal be removed by being partially

dissolved. When the meshes of the fabric are cleansed, it is to be brushed with a hard conical brush, which penetrates the fabric, and afterwards washed in clean water, which removes any substances that might have adhered thereto; after which the metallic fabric is to be wiped inside and out with a wiper, made of a sponge wound upon a stick, and in order to prevent the formation of rust upon the fabric, it is exposed to the heat of a coke or other ardent fire, until perfectly dry. It will be seen that the method of cleansing above described is very simple, and founded upon a well-known chemical reaction, but it will be found to possess considerable advantages over the method now in use.

In pointing out the advantages presented by Mr. Mueseler's lamp, M. Devaux, Chief Engineer of the Mines, acknowledges that the method of cleaning by fire diminishes the duration of metallic fabrics by one quarter. If, therefore, the results of this method shall be found successful on being practically tried, a great saving will be effected in mining operations, which ought not to be overlooked.—*Bulletin de l'Industrie.*

MODE OF ENGRAVING UPON OR ORNAMENTS STEEL AND OTHER METALS, BY MEANS OF ELECTRICITY.

BY MR. J. H. PRING.

THE means which I propose, consists of an application of electricity, which I believe to be new, and shall be happy if it prove to be of practical utility.

The manner in which I have succeeded in producing marks or sketches upon plates of steel is as follows:—

I united six batteries of the kind invented by Mr. Smee, in each of which the size of the plate of platinized silver was about 3 square inches. I fixed the plate of steel to be engraved upon at the zinc end of the batteries. Having placed a wire of considerable length, covered with silk, between the plate of steel and the zinc, I took hold of the wire in communication with the platinized silver, and used it as an etching point upon the plate of steel. A bright electric spark, accompanied by a slight attack upon, or bite into the steel, was the result each time the wire came in contact with the plate.

The wire, which served as a graver, was made of platina; the part which I took hold of was enclosed in a glass tube, in order to facilitate its being taken hold of and moved more easily, and

to protect the hand against the electric shocks to which it would be exposed without this precaution.

On using the wire, in communication with the zinc, as an etching point, and attaching a plate of steel to the platinized silver, a totally different effect is produced. With the apparatus thus arranged, the spark resulting from the contact of the wire with the plate of steel, is accompanied by the deposition of a very small portion of the wire itself upon the steel. By employing wires of different materials, such as gold, silver, platina, &c., a variety of ornamental designs may no doubt be produced upon surfaces of polished steel.

The effects of the electrical influence above described are not confined to steel; a nearly similar result may be obtained by substituting plates of any other metal. It is to be presumed, that by augmenting the quantity and intensity of the electric currents, the effect upon the steel or other metal would be proportionably greater; and it is very probable, that by modifying the process, the application thereof might be advantageously extended.—*Id.*

Scientific Adjudication.

VICE-CHANCELLOR'S COURT.

July 24th, 1844.

BUNNETT AND ANOTHER *v.* SMITH.

THIS was an application on behalf of the plaintiffs, as patentees of certain improvements in the construction of iron revolving window-shutters, for an injunction to restrain the defendant from manufacturing and selling shutters, alleged to be an infringement of their patent, which was granted to the plaintiff, *Bunnett*, in June, 1836. The specification (see Vol. IX. Conjoined Series, p. 275) described his shutters to consist of a series of partially overlapping strips or plates of iron, or other metal, so connected together by a particular description of crank butt-hinge, that the knuckles of the hinges should be hidden by the partial overlapping of the plates, and without such plates being cut away at the upper edges to let in the knuckle of the cranked hinge, which arrangement the plaintiff claimed as the first feature of his improvements; and the specification also described a plan of applying an endless screw or toothed-wheel to the roller on which their shutters revolved, for the purpose of raising and lowering

not only shutters as above described, but any shutters used before the date of his patent, and this arrangement formed the second feature of his improvement. It was for an alleged infringement of the plaintiff's patent in these two particulars that the plaintiff sought the interference of the Court. The plaintiff in his specification disclaimed the various portions of his shutters and lifting gearing *separately*; admitting that each *per se* was old and well known in principle, and in use previous to the grant of his patent, but rested his claims entirely on the novel combination. The circumstances which gave rise to the motion were as follow: It appears that Messrs. W. Cubitt and Co., of Gray's Inn-road, were engaged in making considerable additions to the banking premises of Messrs. Smith, Payne, and Co., in George-street and Mansion-house-place, in the city, and it being determined that iron shutters should be adopted, application was first made by the surveyor of the works to the plaintiffs, who furnished drawings of their shutters and gearing, and gave information as to the smallest space within which they would revolve; but the surveyor, finding that the space required was more than could be afforded in the building, applied to the defendant, Andrew Smith, of Princes-street, Leicester-square, who is also the manufacturer of an improved iron revolving shutter, and was there shewn specimens of the defendant's shutter, which it was stated would occupy less space than that of the plaintiffs, and exhibited other advantages; principally by reason of the outer strips or plates of the shutters being connected by a peculiarly constructed chain, consisting of alternate links of wire and flat plates, in lieu of the crank butt hinge of the plaintiffs; his shutters being also raised and lowered by means of an endless screw and toothed-wheel, similar in principle to that used by the plaintiffs (which is old and well known), though differently arranged, so as further to economise space; and, upon looking into the relative merits of both, the surveyor determined on having Mr. Smith's shutters, and Messrs. Cubitt and Co. accordingly gave orders for several sets of shutters to be affixed to the windows of the building in question, by Mr. Smith. The work was accordingly proceeded with by the defendant; and the plaintiffs, to restrain him from manufacturing, adopted the present motion.

It was contended by Mr. BETHELL (with whom was Mr. Bacon), on the part of the plaintiffs, that the chain of the defendant was a colorable and evasive imitation of the hinge of the plaintiffs, as claimed under the first head of their patent, and that the lifting gearing used by the defendant was also an evasive imitation of the lifting gearing claimed under the second head of their patent. On the other hand it was contended by Mr. STUART, and Mr. T. TURNER, on behalf of the defendant—firstly, that the plaintiffs' patent was altogether bad and invalid on several grounds, and that, therefore, the plaintiffs could not be entitled to the interference of the court, but should be left to their remedy at law;

secondly, that even if the patent were good, the defendant's chain was in nowise similar, either in appearance, principle, or effect, to the crank butt-hinge of the plaintiffs, but infinitely superior in point of durability, and economy of space, and, therefore, could be no infringement; thirdly, that the lifting gearing of the defendant, although similar in principle to the plaintiffs', was differently arranged, and so as to produce a much more beneficial result, and, therefore, was no infringement of the plaintiffs' patent; and lastly, that inasmuch as the plaintiffs had specified for a particular combination of old parts, they were not entitled to, nor could they restrain the defendant from using any of the respective parts unless he also used the whole. Numerous affidavits of scientific gentlemen and others were put in by both sides, and read, and various models, shewing the relative constructions and arrangements of each party, were exhibited; and amongst the evidence brought forward by the defendant to shew the non-existence of novelty in the plaintiffs' patent, were affidavits to the effect, that iron revolving shutters, of a similar construction to the plaintiffs', fastened by hinges on the same principle, were in use long prior to the date of the plaintiffs' patent; also, that the particular description of machinery used for raising and lowering the plaintiffs' shutter, and claimed by the patentee in his specification, was patented and in use about thirty-six years ago, for closing and opening window shutters.

His Honour the VICE-CHANCELLOR said, that where a patent was found to have existed for a period of eight years without any dispute, it was not the habit of the Court to scan very narrowly the expressions used in the specification, and to affirm, because the language was not as clear as it might be, that, therefore, the patent was bad. The long acquiescence of the public rather afforded *prima-facie* evidence that the patent was good. But what pressed upon his mind was, whether the plaintiff had not so described the operation by which a part of the invention was managed, as in effect to permit the defendant to do what he contended the patent left him the right to do. There appeared to his Honour to be a difference in the mode by which the operation of winding up was effected in the two inventions, and it appeared to his Honour that the whole scheme of the thing was to make a succession of hinges, which were so placed that the successive lateral bars lapped over each other, and thus concealed what his Honour might call the cardinal virtues of the whole thing. According to the plaintiffs' plan, the rolling up of their shutters was effected by "the revolving power of one hinge being made to depend upon a piece of the next hinge." Now, in the defendant's alleged piracy, his Honour saw a different piece of machinery, for instead of making the revolving power of one hinge, according to the plaintiff's specification, depend on the adjoining hinge, the defendant did not make his hinge come in contact with the next hinge. It might be for a jury to say whether this were an in-

fringement of the patent or not, but his Honour was not called on to decide such a question on a motion of this sort. It was the custom of the Court in granting injunctions to do as little injury as possible, and, therefore, he thought the proper course was to make no order on the motion, but let the plaintiff proceed forthwith to establish the validity of his patent in an action at law.

COURT OF COMMON PLEAS.

SITTINGS IN BANCO.

May 6, 1844.

STEAD *v.* WILLIAMS AND OTHERS.

IN this case, which was tried at the Liverpool Summer Assizes, 1843, before Mr. JUSTICE CRESWELL, an action had been brought by the plaintiff for the infringement of a patent, dated May 19, 1838, for a certain invention "for making or paving public streets and highways, and public and private roads, courts, and bridges, with timber or wooden blocks."* The specification stated the invention to consist in a mode of paving by means of wooden blocks, cut or formed of similar size or dimensions, of which the hexagonal figure was the best. The blocks of wood were to be placed with the grain vertical, and the size of the blocks recommended was from about 7 to 10 inches in diameter at the top, slightly diminishing to the base, and from about 9 to 12 inches in height. Dowells or pins were also recommended, to secure the blocks from sinking or getting displaced, but were not claimed as a necessary part of the invention. At the trial, the plaintiff having called several scientific witnesses, who stated that they had never heard or known of a wooden pavement prior to the date of the plaintiff's patent, the defendants put in evidence, that in *Newton's London Journal of Arts and Sciences* there was a letter, published in March, 1825, from a correspondent named Finlayson, with plans and descriptions of a pavement formed of wooden blocks, invented by the writer. And also, that the second part of the 49th volume of the *Transactions of the Society of Arts*, for the year 1833, contained a letter by Mr. James Heald, dated October 6, 1832, on the subject of wooden roads, for which he received the thanks of the Society. The instructions given in this letter for the construction of roads on this principle, recommended the use of hexangular blocks of wood, of one foot long, with the fibres of the wood standing vertically; and it appeared that 1500 copies of this letter were published. It was further shewn, that wood had been used as a pavement at Sir William Worsley's, Hovingham Hall, near Whitwell, Yorkshire, where, in 1834, the vestibule, in front of the hall, was paved with hexagonal

* For report of this case see Vol. XXIII., p. 211, Conjoined Series.

blocks, 7 inches deep and 7 inches in diameter, and chamfered round the edges, so as to form a groove round each block. This formed a carriage road 34 feet 8 inches long by 9 feet 10 inches broad, and was a thoroughfare leading from the riding-house into the pleasure ground, and every carriage going to the house passed over it. The learned Judge, in summing up, told the jury that the patent was void, if they thought that the information contained in the letter of Mr. Heard had found its way to the plaintiff; and he also told them, that if they were satisfied that the wooden pavement used at Sir William Worsley's, although a little more bevelled off, was substantially the same thing as the hexagonal blocks introduced by the plaintiff, that would make an end of the patent. The jury found a verdict for the plaintiff, and a rule *nisi* was obtained for a new trial in Michaelmas Term last, upon the ground of misdirection, and also upon the ground that the verdict was against evidence.

Sir T. WILDE and Mr. Serjeant SHEE (with whom were Mr. Crompton and Mr. Webster) shewed cause against the rule.

Mr. Serjeant CHANNELL and Mr. Serjeant BYLES (with whom were Mr. Hoggins and Mr. Warren) were heard in support of it, and contended that the learned Judge was wrong in telling the jury that the knowledge of the publication of the letter must be brought home to the plaintiff. The publication of the letter was itself sufficient to avoid the patent. It was also urged, that the verdict of the jury was directly in opposition to the evidence, and that the title of the patent was too large.

Judgment was deferred.

June 29th, 1844.

Sir N. TINDAL, C. J., now delivered the judgment of the Court.—This was an action on an infringement of a patent granted for an invention for “making or paving public streets and highways, and public and private roads, courts, and bridges, with timber or wooden blocks.” The defendant pleaded, “that the plaintiff was not the first and true inventor of the said invention in the letters-patent and specification mentioned,” besides various other pleas, which it is not necessary to particularize, with reference to the present motion.

Upon the trial at the last Summer Assizes, at Liverpool, before my brother Creswell, a verdict was found for the plaintiff; but a rule *nisi* was afterwards granted for a new trial; and, upon the report of the learned Judge, it appears, that before the granting of the letters-patent to the plaintiff, there had been published in scientific works in England a letter on the construction of paving roads with wood, one of which was from a gentleman named Heard, containing such a description of a mode of paving with blocks, as made it fit to be submitted to the consideration of the jury, as not differing substantially from the invention for which the patent was granted. It appears also, that in summing up

the evidence with reference to the plea above adverted to, the jury were told in substance, that if they thought the patentee had borrowed his invention directly from the publication, which had been proved, he could not be considered as the first inventor. So also, that if the matter had been so far communicated to the public as to have become a part of the public stock of information, and he had thus obtained his knowledge indirectly from the publication, he could not be considered as the first inventor, within the meaning of the statute.

On the discussion before us it was contended, that this mode of summing up, although undoubtedly correct as far as it went, yet did not present the entire view of the case to the consideration of the jury; for it was urged, that, if the invention had been communicated to the English public, although it had never, either directly or indirectly, come to the knowledge of the patentee, still he could not be considered as the inventor. It was admitted on the part of the defendant, that no case could be cited in which the point had been expressly decided; but it was contended, that, on reason and principle, such must be held to be the law; for if the invention had already been communicated to the public, it would be unreasonable that they should lose the benefit of it, and be restricted from making use of it, by a patent taken out by one whose claim to such patent could only be supported on the ground of his being ignorant of that which had already been communicated to the rest of the world; and though no decided case was cited, various dicta of learned judges were referred to in support of the view so contended for by the defendant, particularly what was said by Baron Alderson in *Carpenter v. Smith*, 9 M. & W. 302, and the observations made by Lord Lyndhurst and the other Lords of the Privy Council, as reported in 1 Webster's Patent Cases, pp. 718, 719. Lord Lyndhurst says, "If a machine is published in a book, distinctly and clearly described, corresponding with the description in the specification of the patent, though it has never been worked, is not that an answer to the patent? It is continually the practice on trials of patent rights to read out of printed books, without reference to any thing that has been done." And again he says, "If the invention is in use at the time the patent is granted, the man cannot have a patent, although he is the original inventor; if it is not in use, he cannot obtain a patent, if he is not the original inventor. He is not called the inventor who has in his closet invented it, but who does not communicate it; the first person who discloses that invention to the public is considered as the inventor."

On a full consideration of the subject we have come to the conclusion, that the view taken by the defendant's counsel is substantially correct, for we think that the invention has already been made public in England, by a description contained in a work, whether written or printed, which has been publicly circu-

lated ; in such case the patentee is not the first and true inventor within the meaning of the statute, whether he has himself borrowed his invention from such publication or not ; because we think the public cannot be precluded from the right of using such information as they were already possessed of at the time of the patent being granted.

It is obvious that the application of this principle must depend upon the particular circumstances which are brought to bear on each particular case. The existence of a single copy of a work, though printed, brought from a depository where it has long been kept in a state of obscurity, would afford a very different inference from the production of an Encyclopædia, or periodically published Journal, or other work in general circulation. The question will be, whether, upon the whole evidence, there has been such a publication as to make the description a part of the public stock of information.

We think, therefore, that as this question has not been submitted to the jury, there ought to be a new trial in this case.

Rule absolute.

List of Patents

Granted by the French Government from the 1st of October to the 31st of December, 1841.

(Continued from Page 63, Vol. XXV.)

- Deschamps, of Orleans, for a fabric prepared for the insertion of hair in making wigs.
- Duval, of Paris, for an apparatus to warm shoes.
- Farcot, of Paris, for a machine to make blocks in straight wood for paving.
- Faucille, of Paris, for an economical kitchen stove.
- Filhiol, of Paris, for a surgical instrument, called "antlimakyste."
- François, of Paris, for a pomatum to make the hair grow.
- Gauthière, of Vaucouleurs, for a fire pump.
- Gauthier, of Havre, for a mode of preparing sparkling wines.
- Gounel Audras and Valansot, of Lyons, for an improved batten.
- Graff, of Paris, for a safety lock.
- Grondard, of Paris, for a process to fix iron plates on wood.
- Guilleminot, of Autun, for improvements in wooden shoes.
- Guinier, of Paris, for an improvement in water-closets.
- Hamaun and Hempel, of Paris, for an elliptic compass.
- Madame Horrer, of Nancy, for a new kind of embroidery.
- Hue, of Rouen, for an improved pecker lever for looms.
- Jacquemart, of Paris, for improvements in the roofing of houses.

- Josselin and Bertrand, of Paris, for improved egg-cups, to be heated by warm water.
- Jouassard, for an improved system of eye-flaps for horses.
- Jué, of Paris, for instruments to accelerate the making of gloves.
- Madame Keay, of Batignolles, for an improvement in carriages and spokes of wheels.
- Klotz, of Strasbourg, for an apparatus to filter and clear oils.
- Koechlin and Co., of Mulhausen, for a machine for dressing at once two sets of warp threads.
- Lambert, of Paris, for an improved save-all for burning ends of candles.
- Laurent, of Nancy, for an instrument for taking levels.
- Laroche, of Bergerac, for a process for avoiding dangerous mistakes in the dispensing of medicines.
- Le Gavrian, Dequoy, and Co., of Lille, for a steam-engine.
- Legendre, of Paris, for a steam-engine on the oscillating principle.
- Lemée, of Mont St. Jean, for a manner of teaching materially the metric system.
- Leprince, of Paris, for a machine for pounding.
- Letestu, of Paris, for cylindrical rotatory stoves for steam-engines.
- Levot, of Paris, for soap made with lichen.
- Luchaire, of Orleans, for improvements in gas works.
- Maquet, of Paris, for a machine for making envelopes for letters.
- Marchal, of Amiens, for water-proof shoes.
- Martin, of Paris, for improvements in artificial legs.
- Mauduit, of Paris, for an instrument for draughtsmen and painters.
- Mayet, of Paris, for an instrument to clean combs.
- Mercier, of Lyons, for a new mode of indicating the names of streets.
- Michel, of Paris, for a machine to make rolled bands for the dressing of wounds.
- Monot, of Dijon, for mosaic made on asphalte.
- Montgolfier, of Beaujeu, for a paper machine.
- Morel, of Vienne, for improved spurs.
- Muzzy, of Paris, for an aerostatic machine.
- Perret, of St. Louis, for a machine for screwing and unscrewing nuts.
- Pimont, of Bolbec, for an apparatus for collecting heat.
- Pollet, of Beaume, for an improved steelyard for weighing.
- Prat, of Villac, for an improved drill for sowing corn.
- Potiers, of Paris, for the manufacture of vinegar from corn.
- Raymond and Sausset, of Paris, for improvements in steam boats.

- Renaud, of Paris, for a process called "sertereotype," to fix stones, in imitation of gold.
- Reverchon and Merlavaud, of St. Etienne, for a musical instrument called "odestrepheon."
- Ringuenet and Helans, of Louviers, for an improved batten.
- Robinson, of Paris, for mills for crushing sugar-cane.
- Rosselet, of Paris, for suspension bridges, made of wire or iron bands.
- Sapey, of Paris, for a manner of baking plaster by using anthracite coal.
- Schuyten, of Lille, for a press for copying.
- Seytre, of Lyons, for pianos and organs, called "autopanfones."
- Sisco, of Paris, for improved calefyers and fire-places.
- Tassin, of Lille, for an electrofugal apparatus, to prevent the explosion of steam generators.
- Taysse and Deymarie, of Paris, for a slide applicable to parasols.
- Tussaud, of Paris, for the manufacture of bungs and pegs.
- Vermorel, of Paris, for a new kind of bread called Chinese bread.
- Veron, of Paris, for an improved button for gloves.
- Way, of London, for an apparatus for locking the wheels of carriages.
- Westmcott, of Paris, for wood pavement.

LIST OF REGISTRATIONS EFFECTED UNDER THE ACT FOR PROTECTING NEW AND ORIGINAL DESIGNS FOR ARTICLES OF UTILITY.

- July 30. *William Cotton*, of No. 3, Crosby-square, London, for "Cotton's pocket balance for sovereigns."
31. *Captain Lawrence Crawley*, of No. 45, Edmund-street, Birmingham, for a gun nipple cover, or nipple protector, for regimental or company drill.
31. *John Rowan & Sons*, of Doagh Foundry, County Antrim, for a churning machine.
- Aug. 1. *William Henry Hine Akerman*, of Bridgewater, Somersetshire, for "Akerman's elastic general fitting clog."
2. *The Brades Steel Company*, near Birmingham, for a design for verge shears.
2. *The Brades Steel Company*, near Birmingham, for a design for garden shears.
2. *James Wilson*, of No. 37, Walbrook, for a design for a ventilating hat.

- Aug. 3. *J. Wells*, of Worcester, for a glove of a new cut.
5. *Thomas Wolferstan*, of Salisbury, for an improved carriage spring.
5. *Charles Chinnock*, of Great Portland-street, for an improved reclining chair.
5. *Edmund Spiller*, of No. 98, Holborn-hill, for "the bachelor's tea-kettle heater."
6. *William Wright*, of No. 3, Great Queen-street, Lincoln's-inn-fields, for a design for a metallic safety lucifer match box.
7. *Joseph Skretchly and Thomas Gilbert Norman*, of Leicester, for a clasp for ladies' dresses.
9. *Frederick William Lee*, of No. 46, Southampton-buildings, Holborn, for "Lee's marine life-preserver."
12. *Harry Gills*, of Birmingham, for "Harry Gills' new designed spur-spring and box."
13. *James Lane*, of Wimbourne-street, Hoxton, for a design for a table bracket.
14. *A. Kenrick & Sons*, of West Bromwich, near Birmingham, for a design for apparatus for closing doors.
14. *Jane Leighton*, of Exmouth-street, Spa-fields, for a book file.
16. *Alfred Toy*, of Castle-street, Holborn, for a deflecting glass for spirit lamp.
19. *James Comins*, of King-street, South Molton, for an improved one-way, turn-over, or turn-rest plough, also a hoeing, earthing-up, or potato plough.
22. *Richard Baker*, of Weymouth, for an improved armillary sphere.
22. *Thomas Crump*, of Derby, for a water-closet.
26. *William Reynolds*, of Friendly-place, Mile-end, for an improved quadrant.
26. *Samuel Downer*, of No. 11, Greenhill's-rents, Smithfield-bars, for a cylindrical elbow joint for stove piping.
27. *William Pedley*, of No. 2, Claremont-place, Pentonville, and *Alexander Thorn*, of No. 40, Castle-street, Leicester-square, for a segmental bottle.
27. *Edwin Rose*, of Ogleby, Staffordshire, for a roller.
27. *Kennedy & Asprey*, of No. 49, New Bond Street, for a portable ink and light box.
27. *James Vipond*, of St. Mary-le-Strand Place, for a two-wheeled carriage.

List of Disclaimers
OF PARTS OF INVENTIONS AND
Amendments

MADE UNDER LORD BROUGHAM'S ACT.

Disclaimer and memorandum of alterations of specification enrolled 19th September, 1839, to patent granted to George Nelson, of Milverton, in the county of Warwick, chemist, for "a new or improved method or new or improved methods of preparing gelatine, which has the properties of or resembles glue." Filed 8th August, 1844. Patent dated 23rd March, 1839.

List of Patents

That have passed the Great Seal of IRELAND, from the 17th of July to the 17th of August, 1844, inclusive.

- To William Henry Phillips, of Bloomsbury-square, in the county of Middlesex, engineer, for improvements in the means and apparatus for subduing and extinguishing fire, and saving life and property; and in obtaining and applying motive power; and improvements in propelling.—Sealed 26th July.
- George Miller Clarke, of Albany-street, Regent's-park, in the county of Middlesex, tallow-chandler, for improvements in night lighting, and in apparatus used therewith.—Sealed 31st July.
- George Bell, of Pembroke-road, in the city of Dublin, merchant, for certain improvements in a machine or machines which facilitate the drying of malt, grain, and all kinds of seeds.—Sealed 7th August.
- George Gwynne, of Prince's-street, Cavendish-square, in the county of Middlesex, Gent., and George Ferguson Wilson, of Belmont, Vauxhall, in the county of Surrey, Gent., for improvements in treating certain fatty or oily matters, and in the manufacture of candles and soap.—Sealed 16th August.
- Jacques Bidault, of Paris, in the kingdom of France, merchant, for improvements in applying heat for generating steam, and for other purposes, which improvements may be used for obtaining power.—Sealed 16th August.

Charles William Graham, of King's Arms Yard, in the city of London, merchant, for improvements in manufacturing pathological, anatomical, zoological, geological, botanical, and mineralogical representations in relief; and in arranging them for use,—being a communication.—Sealed 16th August.

List of Patents

Granted for SCOTLAND, subsequent to July 22nd, 1844.

- To David Cheetham, of Rochdale, Lancashire, cotton-spinner, and John Tatham, of the same place, machine-maker, for certain improvements in machinery or apparatus to be employed in the preparation and spinning of cotton, wool, and other fibrous substances.—Sealed 23rd July.
- John Holland Butterworth, of Rochdale, Lancashire, cotton-spinner, for certain improvements in machinery or apparatus applicable to preparation-machines used in the spinning of cotton and other fibrous materials.—Sealed 23rd July.
- Jacques Bidault, of Paris, in the kingdom of France, merchant, for improvements in applying heat for generating steam, and for other purposes, which improvements may be employed to obtain power,—being a communication from a abroad.—Sealed 24th July.
- James Caldwell, of Mill-place, Commercial-road, London, engineer, for improvements in cranes, windlasses, and capstans.—Sealed 24th July.
- James Hardy, of Birmingham, Gent., for certain improvements in the process of welding tubes, pipes, barrels, or hollow rods of malleable iron, by machinery.—Sealed 30th July.
- Joseph Hall, of Bloomfield Iron Works, Staffordshire, iron-master, for improvements in the manufacture of horse-shoe nails.—Sealed 1st August.
- Laurence Hill, Jun., of Glasgow, civil engineer, for improvements in machinery for manufacturing shoes for horses and other animals,—being a foreign communication.—Sealed 1st August.
- Charles Low, of Robinson's-row, Kingsland, in the county of Middlesex, for certain improvements in the making or manufacturing of iron or steel.—Sealed 2nd August.

William Sutcliffe, of Bradford, Yorkshire, manufacturer, for improvements in preparing, dyeing, sizing, or dressing yarns and manufactured fabrics of wool, flax, cotton, silk, and other fibrous materials.—Sealed 6th August.

William Isaac Cookson, of the borough and county of Newcastle-upon-Tyne, for improvements in apparatus for burning sulphur in the manufacture of sulphuric acid.—Sealed 8th August.

James Smith, of Queen-square, Westminster, for improvements in slubbing, spinning, twisting, and doubling cotton and other fibrous substances.—Sealed 8th August.

William Losh, of Newcastle-upon-Tyne, for improvements in the manufacture of metal chains, for mining and other purposes.—Sealed 8th August.

Henry Bewley, of No. 3, Lower Sackville-street, Dublin, apothecary, and George Owen, of the same place, chemist, for improvements in the mode of confining corks, or substitutes for corks, in bottles and other vessels, whether made of glass, earthen or stone-ware, containing liquids, charged or not charged with gas.—Sealed 9th August.

Anthony Lorimier, of Clerkenwell-close, in the county of Middlesex, bookbinder, for certain improvements in the apparatus and means of facilitating drawing from nature or models.—Sealed 9th August.

Pierre Armand Le Comte de Fontainemoreau, of No. 1, Skinner's-place, Sise-lane, London, for an improved crane, called "dynamometric,"—being a communication from abroad.—Sealed 10th August.

Pierre Armand Le Comte de Fontainemoreau, of Skinner's-place, Sise-lane, London, for a new mode of locomotion, applicable to railroad and other ways,—being a communication from abroad.—Sealed 10th August.

Alexander Ewing, of the town of Dumbarton, glass splitter, for certain improvements in the manufacture of crown glass.—Sealed 14th August.

Arthur Wall, of Bisterne-place, Poplar, London, surgeon, for certain improvements in the manufacture of steel, copper, and other metals.—Sealed 16th August.

Stephen Hutchison, of the London Gas Works, Vauxhall, engineer, for certain improvements in gas-meters.—Sealed 16th August.

New Patents
SEALED IN ENGLAND.
 1844.

- To James Kite, of Hoxton, in the county of Middlesex, coal-merchant, for certain improvements in constructing chimneys; and in the means used for sweeping the same; parts of which improvements are applicable to other like useful purposes. Sealed 26th July—6 months for inrolment.
- Edmund Pace, of Hackney, in the county of Middlesex, Gent., for certain improvements in the machinery for figure-weaving in silk and other fabrics. Sealed 26th July—6 months for inrolment.
- Joseph Martin Kronheim, of Castle-street, Holborn, engraver, for improvements in stereotyping,—being a communication. Sealed 29th July—6 months for inrolment
- William Ford, of Lawn End, South Lambeth, drain-tile maker, for improvements in the manufacture of tubes for draining land, and for other purposes; and in drain tiles. Sealed 30th July—6 months for inrolment.
- Edward John Dent, of the Strand, chronometer maker, for improvements in ships' compasses. Sealed 30th July—6 months for inrolment.
- Arthur Powell and Nathaniel Powell, of Whitefriars Glass Works, glass manufacturers, for improvements in the manufacture of quarries, and other panes of glass for windows. Sealed 30th July—6 months for inrolment.
- Joseph Bentley, of Liverpool, gun maker, for certain improvements in fire-arms. Sealed 30th July—6 months for inrolment.
- Thomas Warne, of Blackfriars-road, pewterer and beer-engine manufacturer, for certain improvements in engines, machinery, or apparatus for raising, drawing, or forcing beer, ale, or other liquids or fluids. Sealed 30th July—6 months for inrolment.
- Elizabeth Cottam, of Winsley-street, Oxford-street, for improvements in heating what are called Italian irons. Sealed 30th July—6 months for inrolment.
- Pierre Armand Le Comte de Fontainemoreau, of Skinner's-place, Sise-lane, for certain improvements for coating or covering metals and alloys of metals,—being a communication. Sealed 31st July—6 months for inrolment.

- Benjamin Tucker Stratton, of Bristol, agricultural mechanist, for improvements in welding sheet iron, for ship-building and other uses. Sealed 1st August—6 months for enrolment.
- John Reed Hill, of Chancery-lane, engineer, for improvements in a press or presses, machine or machines, for letter-press printing. Sealed 2nd August—6 months for enrolment.
- William Edwards Staite, of High-street, Marylebone, Gent., for certain improvements in the processes and apparatus for preparing extracts and essences of vegetable and animal substances. Sealed 3rd August—6 months for enrolment.
- Thomas Middleton, of Loman-street, Southwark, engineer, for certain improvements in machinery for the manufacture of artificial fuel. Sealed 5th August—6 months for enrolment.
- Julius Jeffreys, of Clapham, Surrey, Gent., for improvements in respirators. Sealed 6th August—6 months for enrolment.
- Thomas Greenshields, of Oxford, architect, for improvements in the manufacture of salt. Sealed 6th August—6 months for enrolment.
- William Cormack, of Dalgleish-street, Commercial-road, East, chemist, for a new method or plan for purifying coal-gas. Sealed 15th August—6 months for enrolment.
- Thomas Heaton, of Chorley, Lancashire, colliery agent, for certain improvements in hydraulic machinery, which are also applicable to raising other liquids. Sealed 15th August—6 months for enrolment.
- John Whitehead, Jun., of Elton, near Bury, Lancashire, dyer and finisher, for certain improvements in the process of finishing fustians or beaverteens, "satin tops," and other similar cotton fabrics. Sealed 15th August—6 months for enrolment.
- Alexander Ewing, of Dumbarton, Scotland, glass splitter, for certain improvements in the manufacture of crown-glass. Sealed 15th August—6 months for enrolment.
- George Turner, of Gateshead, Durham, Doctor in Philosophy, for an improved mode of directing the passage of, and otherwise dealing with the noxious vapours and other matters arising from chemical works in certain cases. Sealed 22nd August—6 months for enrolment.

CELESTIAL PHENOMENA FOR SEPTEMBER, 1844.

D.	H.	M.		D.	H.	M.	
1	—	—	Clock after the sun, 0m. 15s.	—	—	—	Vesta R. A. 19h. 58m. dec. 26.
—	—	—	☽ rises 8h. 4m. A.	—	—	—	43. S.
—	—	—	☽ passes mer. 2h. 55m. M.	—	—	—	Juno R. A. 8h. 7m. dec. 9.
—	—	—	☽ sets 10h. 23m. M.	—	—	—	44. N.
16	32	—	☽ greatest elong. 27. E.	—	—	—	Pallas R. A. 16h. 6m. dec. 11.
8	17	—	☽ in Apogee	—	—	—	16. N.
4	9	43	☽ in ☐ or last quarter	—	—	—	Ceres R. A. 16h. 11m. dec. 21.
—	—	—	Occul. <i>i</i> Tauri, im. 12h. 51m. em. 13h. 47m.	—	—	—	47. S.
—	—	—	Occul. 105 Tauri, im. 15h. 33m. em 16h. 39m.	—	—	—	Jupiter R. A. 0h. 1m. dec. 1.
5	—	—	Clock after the sun, 1m. 32s.	—	—	—	40. S.
—	—	—	☽ rises 10h. 37m. A.	—	—	—	Saturn R. A. 20h. 13m. dec. 20.
—	—	—	☽ passes mer. 6h. 4m. M.	—	—	—	33. S.
—	—	—	☽ sets 2h. 20m. A.	—	—	—	Georg. R. A. 0h. 18m. dec. 1.
9	6	—	♃'s fourth sat. will em.	—	—	—	9. N.
6	7	26	♃'s second sat. will im.	—	—	—	Mercury passes mer. 0h. 59m.
7	—	—	Vesta stationary	—	—	—	Venus passes mer. 20h. 57m.
—	—	—	Occul. <i>f</i> Geminorum, im. 13h. 58m. em. 14h. 33m.	—	—	—	Mars passes mer. 23h. 1m.
11	33	—	♃'s first sat. will im.	—	—	—	Jupiter passes mer. 12h. 12m.
8	13	18	♀ in conj. with the ☽ diff. of dec. 0. 1. N.	—	—	—	Saturn passes mer. 8h. 25m.
—	—	—	Occul. 29 Cancrī, im. 13h. 12m. em. 14h. 4m.	—	—	—	Georg. passes mer. 12h. 30m.
10	—	—	Clock after the sun, 3m. 14s.	19	7	52	☽ in ☐ or first quarter
—	—	—	☽ rises 2h. 59m. M.	20	—	—	Clock after the sun, 6m. 43s.
—	—	—	☽ passes mer. 10h. 8m. M.	—	—	—	☽ rises 2h. 53m. A.
—	—	—	☽ sets 5h. 4m. A.	—	—	—	☽ passes mer. 7h. 13m. A.
11	6	34	♂ in conj. with the ☽ diff. of dec. 6. 39. N.	—	—	—	☽ sets 11h. 39m. A.
12	1	16	Ecliptic conj. or ● new moon	12	38	—	♃'s second sat. will im.
13	10	2	♃'s second sat. will im.	18	28	—	♂ in Aphelion
13	18	43	♀ in conj. with the ☽ diff. of dec. 0. 15. N.	21	9	6	♃ in oppo. with the ☉
14	13	28	♃'s first sat. will im.	16	—	—	♃ in conj. with the ☽ diff. of dec. 4. 51. S.
15	—	—	Clock after the sun, 4m. 58s.	22	10	56	☉ enters Libra,—Autumn commences
—	—	—	☽ rises 9h. 12m. M.	23	12	4	♃'s first sat. will em.
—	—	—	☽ passes mer. 2h. 22m. A.	25	—	—	Clock after the sun, 8m. 27s.
—	—	—	☽ sets 7h. 4m. A.	—	—	—	☽ rises 5h. 2m. A.
2	0	—	☽ stationary	—	—	—	☽ passes mer. 11h. 19m. A.
16	—	—	☽ in Perigee	—	—	—	☽ sets 4h. 37m. M.
16	7	57	♃'s first sat. will im.	—	—	—	Occul. <i>m</i> Piscium, im. 11h. 56m.
16	10	53	♃'s third sat. will im.	6	37	—	♃'s first sat. will em.
16	11	24	☽ greatest Hel. Lat. S.	25	20	35	♃ in conj. with the ☽ diff. of dec. 6. 48. S.
17	—	—	Mercury R. A. 12h. 45m. dec. 9. 14. S.	26	1	13	Ecliptic oppo. or ○ full moon
—	—	—	Venus R. A. 8h. 44m. dec. 14. 58. N.	26	6	57	♃ in conj. with the ☽ diff. of dec. 5. 37. S.
—	—	—	Mars R. A. 10h. 48m. dec. 8. 49. N.	19	51	—	♃ in oppo. with the ☉
—	—	—		28	1	53	♂ in inf. conj. with the ☉
—	—	—		29	—	—	Occul. <i>p3</i> Arietis, im. 8h. 23m. em. 9h. 22m.
—	—	—		—	—	—	Occul. <i>p2</i> Arietis, im. 8h. 39m.
—	—	—		30	13	59	♃'s first sat. will em.

J. LEWTHWAITE, Rotherhithe.

THE
LONDON JOURNAL
AND
REPERTORY
OF
Arts, Sciences, and Manufactures.

CONJOINED SERIES.

No. CLIV.

RECENT PATENTS.

To LAWRENCE HARDMAN, of Liverpool, in the county of Lancashire, merchant, for certain improvements in machinery or apparatus to be employed in the manufacture of sugar.—[Sealed 5th October, 1843.]

THESE improvements in machinery or apparatus to be employed in the manufacture of sugar, consist in a novel and peculiar arrangement and construction of apparatus, as applied to certain operations in such manufacture, whereby the application of the principle of centrifugal force is effectively employed. The particular process in the manufacture of sugar to which the invention applies, is separating the molasses, and other impure soluble and coloring matter, from sugar. In order that the novel and particular application of the improved machinery may be perfectly understood, the patentee first states the nature of the impurities generally combined with sugar, and the process most usually employed for their separation. The saccharine juice of the cane, the date-palm, the maple, or the beet-root, and indeed of any vegetable, is never obtained in a perfectly pure state, but contains resin,

gluten, with fibre or other coloring and impure matter. When the juice is boiled, which it is requisite should be done as soon as possible, to avoid fermentation, these impurities are, to a certain extent, separated from the sugar, and the separation is often assisted by the admixture of lime and other substances, by which some of the feculencies are caused to rise to the surface in a scum, which is easily taken off; others are precipitated; while the rest are coagulated, so as to be in part removeable by subsidence and filtration. Heat, lime, &c., although they separate the dregs, have, when not carefully employed, a very prejudicial effect on sugar, rendering it uncrystallizable, and inferior in quality; and however carefully they be used, (or if not used), it is always found, on concentrating the juice, that a considerable portion of it does not come to grain, but remains in a semifluid state, enveloping the crystals or grain of the sugar, and from which it requires to be separated before the sugar can be considered as in a finished and marketable state. This semifluid is molasses, and the processes most usually employed for separating it are as follows:—When the juice is concentrated to such a point as may be considered most desirable for granulation, the sugar, combined with its molasses, is poured into hogsheads, cases, forms, or cones, having holes pierced in their bottoms, which, for the time, are plugged up; here it is allowed to cool, and, as far as it will, to granulate; and when it is considered that the grain is sufficiently formed, the plugs are removed, the mass is pricked from below, and the molasses gradually drains from the granulated or crystallized sugar into vessels placed beneath.

In many places it is customary, when the first runnings or molasses is drained from the sugar, to place upon the surface of sugar a mass of wet clay, the water from which, gradually draining through the sugar, carries off with it a portion of molasses and coloring matter, which may have remained adhering to the grain or crystals; and this process is repeated until the sugar is obtained as clear and free from molasses and other impurity as may be considered requisite: the clay being removed after each operation. In

well-appointed sugar-works, a solution of sugar in water, of the consistency of syrup, is made use of, instead of wet clay; as on many accounts it answers better. It is evident that this process of draining must be a slow one, and the time occupied in completing it, and rendering the sugar clean and dry, depends on the quality of the juice, and the care taken in clarifying and concentrating it; accordingly, the time required varies from three or four days to thirty or forty days.

The molasses or drainings from the sugar are partly capable of being crystallized, by again cleansing and concentrating; but as, whilst containing any impurities, it is liable to ferment, and the sugar thereby to become less crystallizable, and deteriorated in value, it is (were it solely on this account) most desirable that the draining should be accomplished as speedily as possible. The present improvements are designed to effect this desirable object, and, by the use of certain apparatus or machinery, to perform that in a few minutes or hours which now occupies several days or weeks, by which means a very considerable saving in the manufacture of sugar will be effected.

There are several modifications or varieties of arrangement proposed, under which the principle of this apparatus may be brought into operation, so as to accomplish the desired effect; the object being, to cause the materials, intended to be dispersed, to revolve at a high velocity, by means of any motive power, whereby a centrifugal tendency will be imparted to them, and cause the liquid and soluble particles to be thrown off: the sugar being placed in a bag, case, or any other suitable vessel, so constructed as to retain the granulated or solid particles, and thus allow of a rapid and effectual separation.

In Plate VII., fig. 1, is a plan or horizontal view of the machine. Fig. 2, is an elevation of the same, with the outer casing removed, in order to expose the interior. Fig. 3, is a plan or horizontal section; and fig. 4, a vertical section, taken through the middle of the machine. *a, a*, is the central shaft of the machine, supported in a footstep or bearing at *b*, below, and in a pedestal or bearing *c*, above;

either attached to a cross-beam, or placed in an independent framing, as preferred. This shaft is made hollow from above, as shewn in fig. 4, and is perforated plentifully with holes all round. Upon the shaft are keyed the top and bottom plates *d*, and *e*, of the revolving apparatus, firmly connected together by means of the vertical ribs *f*, *f*, *f*. This revolving case or drum is divided by means of a fine sheet of wire gauze or cloth *g*, *g*, thus forming the two circular chambers or compartments *h*, and *i*, and the whole is enclosed by means of two thicknesses of wire gauze or cloth *k*, *k*. The upper plate *d*, is furnished with doors, valves, or openings *l*, *l*, for the admission of the sugar; and also openings or valves *m*, *m*, for the admission of air; and the bottom plate *e*, is furnished with openings or valves *n*, *n*, for the discharge of the sugar, after the dispersion of the molasses or other impurities. The bottom plate also bears upon a disc or plate *o*, *o*, which is kept up against the bottom plate *e*, whilst the machine is in operation, by means of the nut *p*, and spring *q*, but is by the same means withdrawn, giving vent to the discharge valves *n*, *n*, after the operation is completed. The whole of this apparatus is to be enclosed in a casing or chamber, *r*, *r*, which remains stationary, and may be open at the top, and provided with discharge-pipes or valves *s*, *s*, by which the molasses or other matter, discharged from the sugar, is drawn off. This apparatus is to be put in motion by means of any suitable gearing, or by a strap passing round the driving-pulley *t*, above.

The operation of the machine is as follows:—The sugar in its raw state (combined with molasses, &c.), is to be placed in the compartment *i*, *i*, of the revolving apparatus, through the opening *l*, *l*, and a high velocity (say, eight hundred or one thousand revolutions per minute) given to this chamber, through the driving-shaft *a*, *a*; when the molasses and other soluble matter will, by centrifugal force, be immediately dispersed through the gauze or cloth *k*, *k*, (which is of too close a texture to allow any of the granulated sugar to escape) into the outer casing *r*, *r*, and pass off by the pipes *s*, *s*, below, and thence conducted into any convenient cistern: the dried sugar will be retained in the chamber *i*, *i*, and

may be removed by the openings *n, n*, on releasing the bottom plate *o, o*.

When the molasses is sufficiently dispersed from the sugar, a quantity of syrup may be introduced down the hollow shaft, and pass through the perforations and gauze *g, g*, into the chamber *i, i*, when the apparatus may again be caused to revolve rapidly, and a portion of the impurities which may remain adhering to the sugar will be carried off: this process may be repeated as required.

The patentee claims the application of the principle of centrifugal force, for the separation or dispersion of molasses, and other soluble impurities and coloring matter, from sugar; and as a means of syruling or watering sugar, from which its molasses and impurities have been in part removed, in order further to cleanse and purify the same.—[*Inrolled in the Petty Bag Office, April, 1844.*]

Specification drawn by Messrs. Newton and Son.

To THOMAS GRIMSLEY, of Oxford, sculptor, for a new method of constructing a self-supporting fire-proof roof, and other parts of buildings, with bricks and tiles, formed from an improved machine.—[Sealed 14th May, 1844.]

THE first part of this invention consists in constructing or erecting upon the side walls of buildings, at convenient intervals, a number of narrow and separate arches or spans, or rather strips of arches, extending across the space intended to be covered. The arches are constructed of bricks, moulded into the required form, so that each brick or block may fit accurately into the place for which it is intended, and in order further to secure the bricks or blocks, a tenon is formed on one of their ends, which fits into a corresponding mortice or recess made on the end of the adjoining block. The external sides of the bricks or blocks, which form the arches, have also grooves made in them, so that, when completed, a narrow groove runs along each side of the arches. These grooves are intended to receive and sup-

port the peculiarly-formed tiles, which fill up the space between the arches, and also sustain each other by means of grooves and tenons, as will be hereafter explained. The inner portions or edges of the arches or ribs may be ornamented in any manner, such as forming a beading, cornice, or other device thereon, thereby giving the roof, when completed, a very neat and elegant appearance.

In Plate VIII., fig. 1, represents a sectional view of a roof, constructed upon this improved plan, and ornamented with cornices and tracery work in the Gothic style. Fig. 2, is a side elevation, shewing the external appearance of the roof when completed. *A, A,* are the side walls, built of brick or stone in the ordinary manner. *a, a,* are blocks or bricks, made of clay or brick earth, moulded in any convenient manner, and afterwards burnt or baked in the usual way. The bricks or blocks are ornamented with a corbel head or other device, from which the arch springs, as shewn in the figure. On the upper end of the block *a, a,* a tenon or projecting piece is made, as shewn by dots in the figure, and this tenon fits into a corresponding recess made in the lower end of the second block *b, b,* which forms a continuation of the arch or rib. The block *b, b,* is also furnished with a tenon, which fits into a recess made in the block *c, c,* immediately above. Another block *d, d,* behind the block *c, c,* is cemented to the latter, and retained in its place on the wall by a projection on its under side, as shewn by dots in fig. 1. Both the blocks *c, c,* and *d, d,* have feathers or tenons *z, z,* on their sides, for the purpose of fitting into recesses in the adjoining blocks, and thereby forming a firm and compact cornice.

The fourth block *e, e,* is one of larger dimensions, and carries at its outer side a portion of the gutter *f.* The form of this block will be best understood by inspecting fig. 3, which represents a plan view of the block detached. All these blocks, strictly speaking, constitute part of the wall, although they also carry (internally) portions of the arch or rib, which is exposed to view inside the building. The blocks above fit one in the other, so as to complete the arch or rib, as shewn in fig. 1. Fig. 4, is a sectional view of a portion of the roof, on an enlarged scale, and taken in the line *, *,

of fig. 1. Each of the blocks, it will be seen, is furnished with a tenon or feather *z*, at one end, and a recess or mortice at the other, so that, when the blocks are placed in their relative and proper positions, and cemented together with Roman or other strong cement, they will constitute a stiff and rigid rib or arch. The recesses or grooves *g, g*, on each side of the block or brick, seen best in fig. 4, form, when the blocks are arranged in their proper places, a long groove along each side of the arch or rib, as seen at *g*, fig. 1.

If it is thought desirable to ceil the roof inside, then proper rafters for carrying the laths and plaster must be employed. For this purpose recesses *h, h*, are made on each side of the blocks, for the reception of the ends of rafters or joists *i, i*, fig. 4, upon which the laths for plastering are nailed in the usual manner; or, if preferred, the ceiling may be formed of tiles, connected together in a similar manner to that hereafter described, in reference to the outward covering, but the lath and plaster will be something lighter.

The point or inner end *j*, of the blocks is ornamented, to present the appearance of an ornamental rib or cornice when the blocks are united. The arches or ribs may be placed at any convenient distance apart, according to the size of the roof, and the taste of the builder.

The form of tile preferred is shewn at figs. 5, and 6; the former representing a plan view, and the latter an edge view. Fig. 7, represents a sectional view of three tiles, connected together as they would be when forming part of a roof. The lower half of each tile is furnished with a groove, as at *k*, and the upper end with a feather edge, as at *l*; but tiles of any other form, if constructed on the self-supporting principle, may be employed. In commencing the operation of tiling, the patentee uses a tile of half the usual size, or rather a section of a tile *b*, fig. 2; he then takes another half-tile, such as that shewn at *c*, and commences therewith the dripping-eave; the tiles are then arranged in the order represented by the numbers in fig. 2, care being taken to cement them well together with Roman cement at all the joints, especially in the grooves made along the sides of the arches. By this means a very light, inexpensive, strong, and perfectly

watertight roof is produced, without any timber, except such as is necessary to support the ceiling, when any ceiling is required; but such timber does not in any way assist in sustaining the roof.

A mode of constructing ornamental chimney-shafts, and also the coping of walls, embodying the same principle as the roof above described, is shewn at figs. 8, 9, and 10. It will be seen, on referring to this latter figure, that each tile is furnished with a feather edge on two of its sides, and a groove on each of the others, so that when a number of tiles are brought together, and properly set in Roman cement, the whole mass is firmly secured.

Fig. 11, represents, in section, a portion of a wall, with a moulded coping, formed of three blocks or bricks. The method of arranging these is so clearly shewn in the drawing, and the application of the invention to constructing the jambs and heads of windows, doors, tracery, and other parts of buildings, is so evident, that it will be unnecessary to enter into any further detail. The bricks and tiles, employed for the purposes above mentioned, are moulded in any convenient apparatus in which pressure can be applied to bring out the ornaments sharply, and they are afterwards burnt in the usual manner. Clay, as stiff as it can possibly be worked, is preferred; and it is found advisable that the moulds should be supplied with exactly the proper quantity of clay; to effect which object with certainty and facility, the machine or apparatus shewn in the following figures has been constructed. It consists of a rectangular box, of any convenient size, and furnished with moveable sides and ends, so that when the box has been filled with clay, and properly trodden or rammed down, the contents may, by removing the sides and ends, be cut away in proper quantities, according to the purpose for which the clay is required. Fig. 12, represents a horizontal sectional view of the machine, and fig. 13, a side elevation, with all the several parts in their proper places, and ready to receive a charge of clay. Fig. 14, is another elevation, with the moveable sides and ends removed, and shewing the clay all ready to be cut away from the mass in proper quantities, in the manner hereafter explained. Fig. 15, is a plan or horizontal view of fig. 13. Fig. 16, is

an end view of the machine, with the moveable sides and end removed; and fig. 17, is a plan or horizontal view, shewing the manner of cutting the clay into lumps or pieces of the proper quantity. *a, a, a, a*, are four upright posts, firmly fixed in the wooden framing *b*; and *c*, is a piece of timber, which forms the bottom of the box, and is supported upon transverse pieces *d, d, d*; all these parts are firmly fastened together in any convenient manner, the bottom piece *c*, projecting above the side-framing *b*, as seen in fig. 14. The moveable sides *e, e*, have long vertical slits made therein, as seen in fig. 13, and when they and the moveable ends are placed in the spaces *f, f*, and *g, g*, fig. 12, the former rest upon the transverse pieces *d, d, d*, and both sides and ends are held securely by the top framing *h, h*. Previously, however, to putting on the top framing a number of wires *i, i, i*, fig. 17, are passed down the vertical slits made in the moveable sides, and laid across the bottom piece *c*, of the apparatus. Two other wires *j, j*, are laid lengthwise along the bottom, and when the framing *h, h*, is properly placed, the box is filled with clay, and trodden or rammed down hard. The framing *h, h*, is then removed, and the wires *j, j*, are drawn up, and thereby made to cut away the clay from the sides *e, e*; the other wires *i, i, i*, are then drawn up, and the clay is cut into portions, as shewn in fig. 14. This having been done, and the moveable sides and ends removed, two moveable bars or rods *k, k*, figs. 14, and 16, are placed in the vertical grooves made in the upright posts *a, a*, as seen in the latter figure. These bars or rods are held up by pins *l, l*, inserted into holes made in the posts *a, a*, for that purpose. When the bars or rods *k, k*, are thus placed, a wire or other cutter is run along the top of them, in order to cut away and remove any superfluous clay, and reduce the mass to a regular cube; this having been done, the pins *l, l*, are taken out, and the bars *k, k*, moved down another hole, when the same operation of passing a wire or cutter along their upper edge, and through the mass of clay, is performed, for the purpose of cutting a layer of clay; the bars are then moved down another hole, and the operation is repeated, until the whole mass is cut up into cubes of the required

size. The cubes or lumps of clay are taken from the machine, and placed in the moulds, where they are brought by pressure into the required shape, such as is shewn at figs. 3, 5, and 6.

The patentee's claims are, Firstly,—constructing roofs of buildings, by substituting, for ordinary ribs or rafters, a series of arches, or strips of arches, made of bricks, stones, or other incombustible materials, the spaces between which ribs being filled up by tiles, slabs, plates, or other suitable means, so as to complete the roof without wood-work, in the manner above described. Secondly,—constructing the other parts of buildings in the manner shewn and described in reference to figs. 8, 9, 10, and 11. Thirdly,—the use of a machine or apparatus, constructed in the manner above described, whereby a mass of clay may be divided with facility into cubes of a proper size for any of the purposes for which such an operation may be required.—[*Inrolled in the Petty Bag Office, July, 1844.*]

Specification drawn by Messrs. Newton and Son.

To WILLIAM LANCE, of George-yard, Lombard-street, in the city of London, insurance-broker, for a new and improved instrument or apparatus to be used in whale fishery; part or parts of which, upon an increased scale, are also applicable as a motive power for driving machinery.
—[Scaled 11th June, 1840.]

THIS invention consists, firstly, in certain alterations in and additions to the ordinary harpoon, by means of which it is forced into the body of the whale as the animal moves onward, after having been struck, and an explosion is also caused within its body, so as to render unnecessary the "lancing," at present required to kill the whale. Secondly, in a mode of throwing the harpoon, so as to project it with much more force than can be accomplished by the present method. Thirdly, in applying part or parts of the above-mentioned apparatus, on a different scale, to the purposes of motive power.

In Plate IX., fig. 1, represents one of the improved harpoons; fig. 2, shews the transverse form of the harpoon-head; and fig. 3, is a face view of a fly or set of fans, of a different form to that which is attached to the instrument in fig. 1. It consists of a spindle or rod *a*, with a quick-motion screw-thread formed along its whole length, working into a female screw in the head *b*, of the harpoon, and connected to its point *c*, for the purpose of forcing the same into the body of the whale. To the other end of the rod *a*, is attached, by any convenient means, and having a universal joint, a fly *d*, (or a screw, or any section of a screw, may be used); and the action of the water against the arms or fans of the fly, as the animal proceeds, causes them to revolve, together with the rod *a*, and force the point *c*, forward into the whale's body. A closed metallic vessel *e*, is proposed to be attached to the harpoon, by a line, or otherwise, to serve the purpose of what is called in the fishery a "drogue," and, by its buoyancy, impede the progress of the whale. The fly or screw may be attached to the "drogue" or vessel *e*, if preferred, and so impart motion, through the line or other connection, to the rod *a*.

At fig. 4, is shewn a somewhat varied form of instrument, to be projected by the means hereafter described. It consists of a harpoon-head, of a conical shape, made with triangular cutting edges towards the point, and furnished, at its base, with barbs or "flocks" *f*, turning on pivots at *g*; these barbs expand, when the strain comes upon the line, and prevent the instrument from drawing out. Fig. 5, exhibits, in section, a similar form of instrument, to be made either with or without cutting edges, but without barbs; this instrument is furnished with the means of effecting an explosion, when it has penetrated into the body of the whale; it consists of two arms or levers *h*, *h*, turning on pivots *i*, *i*, (see the enlarged view, fig. 6,) the outer ends of which arms or levers *h*, *h*, diverge (as shewn by dotted lines in fig. 5), on meeting with resistance from the body of the whale, as the instrument enters, and their inner ends are thus brought into contact with, and caused to break, a small tube or vessel *j*, placed between them, in an aperture communicating with a charge

of gunpowder or other explosive mixture in the chambers k, k , formed in the conical part of the instrument. The tube or vessel j , contains a small portion of concentrated sulphuric acid, and is surrounded by a composition of chlorate of potash and sugar; the action of the acid upon the composition, on the vessel j , being broken, produces ignition, and fires the charge. Fig. 7, is a view of the conical part of the instrument, representing it as rolled out, on the principle of a chart upon Mercator's projection: the object of this view being to shew the relative situations of the chambers k, k .

Fig. 8, is an elevation of the gun or apparatus to be used for projecting the instruments represented at figs. 4, and 5; and fig. 9, is a transverse section, on the line A, B , of fig. 8; any other apparatus, worked by steam or other power, may be employed, if preferred. l , is a tube furnished with a globe or reservoir m , for compressed air, and mounted upon a standard n , which is fitted into a socket in any convenient part of the boat; the charge of air is supplied to the globe m , by means of a flexible metallic or other tube, communicating with a reservoir in the boat; the admission of the air being regulated by the cock n . The discharge is effected by rapidly turning the handle o , which opens the valve p , by the action of the screw q , and thus allows the air to rush into the tube l . The apparatus employed for compressing the air is represented, in section, at fig. 10. r , is a large oval vessel, with an ordinary hydraulic pump s , fixed at its side, by means of which water or other fluid is forced from the well or chamber t , into the cylinder r , and compresses the air, contained therein, into the reservoir to be carried in the boat. The vessel r , is provided with a cock u , at top, for the admission of air, and a cock v , at the bottom, for the egress of the water or other fluid; and is alternately filled and discharged, until the required pressure is obtained.

At fig. 11, a brake is represented, which is to be used in place of the ordinary "logger-head" of the whale boat; it consists of a barrel, suitably mounted in bearings, and having a flange upon it, which is partly embraced by a band of metal, attached to a lever, so loaded, that the resistance to the running of the line is almost sufficient to carry down the

boat, but it yields, and allows the line to run, as soon as the strain upon it is greater than would be safe.

Under some circumstances, it will be found desirable to use the instrument shewn at fig. 1, with its "drogue," for the purpose of impeding the progress of the whale, until another boat came up; and this instrument might, with some slight modifications, be made to effect an explosion.

The application of parts of the above improvements, upon an increased scale, as motive power for driving machinery, consists, firstly, in the use of air, highly compressed by the before-mentioned process. The air is condensed in a vessel of sufficient strength, and supplied to the cylinder of the engine which is to be worked, after passing through a coil of tubing, immersed in any substance which, by the application of heat, will increase its elasticity, or it may be supplied direct from the vessel to the cylinder; and secondly, in an application of the fly, screw, or set of fans, referred to in the description of fig. 1, by mounting them in any convenient and substantial manner, so that, being immersed in a running stream, the action of the water upon their face, at an angle to the plane of their motion, shall cause them to revolve, and thus communicate motion, through suitable gearing, to the machinery to be driven.

The patentee claims, Firstly,—the apparatus in whole or in part set forth, to be used in whale fishery; to the precise form of which, however, he does not confine himself. Secondly,—the use of compressed air as the means of projecting any missile for taking or destroying whales. Thirdly,—effecting an explosion in the body of the whale, distinct from that by the use of rockets. Fourthly,—the employment of air, highly compressed (by the means hereinbefore explained), as a motive power. And, Fifthly,—the use of the fans or screw for driving machinery in the way above mentioned; but he does not confine himself to any particular form or number of fans.—[*Inrolled in the Rolls Chapel Office, December, 1840.*]

To WILLIAM FAIRBAIRN, of Manchester, in the county of Lancaster, engineer, for certain improvements in machinery used for propelling vessels by steam power.—[Sealed 7th March, 1844.]

THIS invention relates to those steam-vessels in which screw-propellers are employed; and consists in fixing a large internal-toothed wheel upon the driving-shaft of the steam-engine, into which a small wheel upon the screw-shaft gears; and, by this means, the screw-shaft is caused to revolve at a much greater speed than the driving-shaft.

In Plate VIII., is a representation of this arrangement. A, is the driving-shaft; B, the internal-toothed wheel fixed thereon; C, the screw-shaft; and D, the small wheel, fixed upon it, and driven by the wheel B.

This application of the internal-toothed wheel, for driving the screw-shaft, admits of its being placed much lower in the vessel than a wheel of the same diameter, with teeth on its periphery; and a greater number of teeth of the wheel on the screw-shaft take into the teeth of the driving-wheel, by being placed within it; whereby the power is transmitted through, and the strain borne by, a greater number of teeth, at one time, than would be the case if the small wheel was placed outside the driving-wheel.

The patentee claims, as his invention, such application of the wheels B, and D, as described and shewn, for the purpose of driving screw-propellers, or other propellers, which act as screws in the water.—[Inrolled in the Inrolment Office, September, 1844.]

To JOB HAINES, of Tipton, in the county of Stafford, coal-master, and RICHARD HAINES, of Tipton, aforesaid, coal-master, for an improved method or methods of making or manufacturing links for the construction of flat chains, used for mining and other purposes.—[Sealed 13th February, 1844.]

THE object of this invention is to give great strength and durability to that description of chains which are termed

flat chains, and to render them as strong at the joints of the links as at any other part ; this is proposed to be effected by making the links of the form represented in Plate VII. Fig. 1, is a side view, and fig. 2, an edge view of part of a chain, constructed with these links ; fig. 3, is a transverse section, on the line A, B, of fig. 1. The middle portions of the links *a, a*, are made of an oval form (in their cross section), and the ends are enlarged into bosses, of an oval figure ; through these bosses holes are drilled, to receive the pins *b, b*, which are, in the first place, formed with a rounded head at one end, and, after being inserted in the bosses, a similar head is formed on the other end, by hammering. The form of the links *c, c*, is similar to that which would be produced by dividing one of the links *a, a*, longitudinally, into two equal parts ; but the middle portions of the links *c, c*, are somewhat wider than the middle portions of the links *a, a*. The relative proportions of the different parts is clearly shewn in the drawings, and it is from a strict adherence to them that the above advantages are to be obtained. The links are made of bar-iron, by passing it through a pair of rolls (as in the ordinary process of rolling iron), with suitable grooves and recesses in them, to give the required shape to the middle portions of the links, and to form the bosses at each end, so that each link may be separated from the rest by cutting between its bosses and those of the adjoining links ; after which, the shapes of the links are perfected, by subjecting them, separately, to pressure in a pair of moulds.

The patentees claim, as their invention, the improved method or methods, hereinbefore described, of making or manufacturing links for the construction of flat chains, used for mining and other purposes ; the essential character of the said improved method or methods being, that links, of the forms and proportions represented in the drawing hereunto annexed, and hereinbefore fully described, are prepared, by rolling bars of heated iron between a pair of revolving grooved rollers, with the flat side of such bars uppermost, and with such enlargements or cavities in the said grooves as will leave enlargements of the thickness of such bars, to form bosses on the flat surface or surfaces, as well as

enlargements of the width of such bars, at both edges thereof; such enlargements of thickness, and of width, being at proper distances apart, along the bars, suitably for the bosses at the ends of such links, as aforesaid.—[*Inrolled in the Rolls Chapel Office, August, 1844.*]

To JOHN WORDSWORTH ROBSON, of *Jamaica-terrace, Commercial-road, engineer, for certain improvements in machinery and apparatus for raising, forcing, conveying, and drawing off liquids.*—[Scaled 8th September, 1842.]

THE first part of this invention consists in a wheel for raising water, represented in Plate IX., fig. 1, being a side view thereof; and fig. 2, a transverse section. The wheel may be made of boiler-plate or sheet-iron, or any other suitable material, each side being firmly bolted to four arms *a, a, a, a*, projecting radially from the axle *b*. It may be divided into four compartments, as shewn in fig. 2, "or into as many divisions as will admit the fluid upon a part of a circle, and discharge the same upon a horizontal line with the axle or centre of the wheel; the fluid, entering the wheel upon a part of a circle, is continually varying its position during the rotation of the wheel, the fluid approaching the centre as it becomes raised, and diverging as it is discharged in a line horizontal to its axis, by which a preponderating leverage is obtained at this point." The air passes from the compartments of the wheel through holes *c, c*, in the sides. The patentee states, that he employs a pump, constructed as hereafter described, for filling the compartments, in order to place the machine in equilibrium, when a small power will keep it in rotary motion.

The second part of this invention consists in a pump for raising liquids from any number of reservoirs into one general suction chamber, and forcing the liquids into a receiver above; from whence they are conveyed, through pipes, to any desired place. Fig. 3, is a vertical section of the pump; and fig. 4, a plan view of the plate containing the valve-seats. *d*, is the general suction-chamber, furnished

with stop-cocks *e, e*, for the admission of the liquid; on the top of this chamber is fastened the plate *f*, containing the valve-seats, and other openings; and upon the plate *f*, is fixed a receiver *g*, to the top of which a pipe is screwed, for carrying off the liquid. At each side of the receiver is a pan or pump cylinder *h*, having a metal cap *i*, bolted thereon; and between the flanges of the cylinder and its cap, the edges of a flexible diaphragm *j*, are secured; this diaphragm is composed of several thicknesses of leather, or any other flexible substance, with layers of India-rubber between them; and the centre of the diaphragm is enclosed between two strong plates, to which the end of the rod *k*, is attached. The action of the parts connected with each cylinder *h*, is as follows:—Upon the diaphragm being raised by its rod *k*, the liquid, which has entered the general suction-chamber through the stop-cocks *e, e*, raises the valve *l*, and passes through the opening which it covers into the cylinder *h*; the motion of the diaphragm being then reversed, the valve *l*, is closed, and the liquid proceeds through the opening *m*, into the passage leading to the opening covered by one flap of the double valve *n*, which, now rising, admits the liquid into the receiver *g*, from whence it is carried off by a pipe, as above mentioned. The motion of the diaphragms being so arranged, that one shall be descending while the other is ascending, a continuous stream of liquid will be discharged from the receiver.

The patentee states, that he does not claim, under the first head of his invention, the exclusive use of any of the separate parts, above mentioned, except so far as the same may be used in combination for the purposes of his invention; the first part of which consists in the construction of a wheel for raising water, whereby the water, contained in the compartments formed in the wheel, is continually varying its position, during the rotation of the wheel; the fluid approaching the centre as it becomes raised, and diverging as it is discharged in a line horizontal to its axis, by which a preponderating leverage is obtained at this point, as herein-before described.

With regard to the second part of his invention, he states,

that he does not claim the exclusive use of any of the separate parts, except so far as the same may be used in combination for the purposes of his invention; the second part of which consists in the particular combination and arrangement of parts, above described, for the construction of a pump, for raising and forcing liquids. And he also claims the application of India-rubber, whether in solution or sheets, to diaphragms or pistons of leather, as described and represented, whereby a more perfect vacuum can be obtained than by the use of leather only.—[*Inrolled in the Rolls' Chapel Office, March, 1843.*]

To WILLIAM THOMAS, of Cheapside, in the city of London, merchant, for an invention of an improved fastening for wearing apparel; and which may also be applied as a fastening to portmanteaus, bags, boxes, books, and other things,—being a communication from a foreigner residing abroad.—[Sealed 6th September, 1843.]

THIS invention, which was communicated to the patentee from abroad, consists of an improved fastening, of a peculiar construction, whereby the various parts of dress or other articles to which it is applied, may be easily, quickly, and simultaneously detached from one another. The improved fastening is susceptible of considerable modification in its external appearance, according to the particular purpose for which it is intended to be employed.

The object proposed by the inventor, is to produce a fastening which presents great facility for detaching or unloosing it, when required, and in so arranging the parts that when any number of fastenings are ranged one above another, in a row, they may be all simultaneously detached, instead of being obliged to unloose them singly, as is the case with most of the fastenings for apparel which are now in use.

The principle upon which the improved fastening is constructed, and the object intended to be effected thereby, will be seen in the drawings Plate VII., in which fig. 1, represents a front view, and fig. 2, an edge view of a fastening intended to be applied to the back or front of a lady's dress

or stays. *a, a*, is a thin blade of steel or other metal, or suitable substance, carrying three small flat boxes *b, b, b*, into which the tongues *c, c, c*, of the blade *d, d*, are inserted, when the fastening is intended to hold two parts of a dress together. The tongues *c, c, c*, have small springs or projections formed on their under side, as seen in the back view, fig. 3. Another thin and narrow blade *e, e*, is connected to the blade *a, a*, and passes through the boxes *b, b, b*, as shewn at fig. 1, and in the detached view fig. 4, in which latter figure it will be seen that the blade *e, e*, has catches or projections *e*, e*, e**, formed thereon, corresponding to the projections on the under side of the tongues *c, c, c*, as represented at fig. 3. The blade *e, e*, is held in its proper position by a small spring, placed in the uppermost box *b**, of the metal blade *a, a*, but which yet allows the blade *e, e*, to slide on the blade *a*, when required. When in a state of rest, the projections or spring-catches on the blade *e*, are opposite the openings in the boxes *b, b, b*, into which the tongues *c, c, c*, of the other blade *d*, are inserted; therefore, when these tongues are inserted, the projections or small spring-catches on their under side catch against the projections on the sliding-blade *e, e*, and retain the two blades *a, a*, and *d, d*, in connection.

When it is desired to unloose the fastening, all that is required to be done, is to overcome the force of the spring in the box *b**, (which keeps the sliding-blade *e*, in its place) by drawing the blade *e*, down, so as to bring a plain part of the blade opposite the projections or catches on the tongues *c, c, c*; this being done, the tongues may be easily withdrawn, and the parts of the dress thereby detached from each other. If thought more convenient or desirable, the tongues *c, c, c*, may be fastened on to the dress without the blade *d, d*, as also may the boxes *b, b, b*, without the blade *a, a*; but the sliding-blade *e, e*, must still be retained, and may be worked as easily without as with the blades *a*, and *d*, which only act as carriers or supporters for the tongues *c, c*, and boxes *b, b*, which latter, when the blades are dispensed with, are connected to the dress in a similar manner to that adopted with hooks and eyes.

Sometimes, in place of the sliding-blade *e, e*, a wire or thin metal rod is employed; this wire or metal rod must be prepared in such a manner, at those points where the tongues *c, c, c*, come in contact with it, that it will act as a catch to retain the tongues in their places. In order to do this, those parts of the rod are flattened out, and an edge turned up, so as to form a sort of catch.

A modification of the above fastenings, as applied to the busk of ladies' stays, is represented in figs. 5, and 6. Fig. 5, represents the two blades in connection; and fig. 6, is a cross section of the same. In these figures, in place of affixing or connecting the boxes *b, b, b*, to one of the blades, as in figs. 1, and 2, the boxes are formed by stamping or punching up part of the blade; a longitudinal slit is then made in the outer side of the box thus formed, for the purpose of receiving the tongues of the opposite blade; and a transverse slit is made in each end of the box to admit the sliding rod *e*, which is furnished with catches or projections, as in the former figures, and as seen in fig. 4. The sliding-rod *e*, is also kept in its place by a spring placed at, and connected to, its upper end, as in figs. 1, and 2. The tongues of the blade *a, a*, are constructed as already explained, in reference to the before-mentioned figures, or may be made in any other convenient manner, if thought more desirable. In order to unloose or detach the two blades *a, a*, and *d, d*, from each other, the sliding-blade, or rod *e*, is pulled down, to bring a plain part thereof opposite the catches of the tongues *c, c, c*, which are then easily removed.

Figs. 7, and 8, represent a modification of the two previously described fastenings, which are much simplified, the sliding-blade, or rod *e*, in this instance, being dispensed with. The fastenings are arranged one above another, as in the former instances, and may like them be simultaneously detached: fig. 8, is a cross section of fig. 7. The tongues *c, c, c*, in these figures, are furnished at their under side with projecting pieces or catches, which hook into longitudinal slits made in the opposite blade, and which slits are covered with spring-pieces *f, f, f*, that are rivetted on to the blade *a, a*, as seen in the drawing.

It will now be understood, that when the tongues, with their projecting pieces, are brought into contact with the opposite blade *a, a*, between the blade itself and the spring-pieces *f, f, f*, that it forces up these pieces, and the projections on the under side of the tongues *c, c, c*, fall or drop into the longitudinal slits of the blade *a, a*, and are retained therein by the said spring-pieces. In order to detach or unloose the fastening, it is only necessary to bend up the two blades *a, a*, and *d, d*, so as to form an obtuse angle with each other, and the tongues; then press back the spring pieces *f, f, f*, and allow the catches or projections on the former to escape from their confinement. If thought more desirable, the tongues, instead of having catches on their under side, may be furnished with longitudinal slits, as seen in fig. 9; a portion of the blade *a, a*, is in this case punched up from beneath, so as to form projecting catches to hook on to the slits of the opposite blade; these catches are covered with spring pieces *f, f, f*, as in fig. 8, which act in precisely the same manner as has been already described.

In figs. 5, and 7, it will be seen that the blades *a, a*, and *d, d*, are brought flush up against each other, the edges being parallel, and in contact, or nearly so, and by this means the fastening is made very flat and thin, and has not a clumsy appearance.

Figs. 10, 11, 12, 13, and 14, represent different views of the improved fastening applied to a boot or trouser strap; fig. 10, is an external side view of the fastening complete, as applied to a trouser and strap; fig. 11, is a side view, detached, of that part of the fastening which is connected to the trouser, and which answers to the blade *d, d*, referred to in explanation of figs. 1, 3, and 5, as it carries the tongues *c, c*, with their spring-catches; fig. 12, is a longitudinal section of the box part of the fastening, shewing the sliding-blade *e*; fig. 13, is an edge view; and fig. 14, a front view of the sliding-blade *e*, detached, and shewing the projecting catches *i, i*, formed thereon or attached thereto, for the purpose of retaining or holding in the tongues *c, c*, of the blade *a, a*. The sliding-blade *e*, is furnished with a spring *h*, for the purpose of bringing it back again into its original posi-

tion, when it has been drawn outwards to allow the tongues *c, c*, to be withdrawn.

Figs. 15, 16, 17, 18, and 19, represent various views of the improved fastening, adapted to a carpet bag. In this adaptation of the invention, the sliding-blade, or rod *e*, which is employed, is thrown or forced back by means of a key. The various parts are constructed and arranged very much in the same manner as has been described in the other figures. Fig. 15, represents a plan or top view of the fastening, in which the two sides or flaps are seen connected together, as when the bag is closed. Fig. 16, is a similar view, except that the parts are shewn separated. Fig. 17, is a side view of one of the flaps or wings which form the framing of the upper part of the carpet bag; *b, b, b*, are the boxes in which the sliding-blade or rod *e*, moves. This sliding-rod, or blade, is seen detached in fig. 18, which represents an edge and plan view thereof. The lock, by means of which the sliding-rod is moved, is seen in fig. 17, at *k*, and the spring whereby it is drawn back into its original position, at *l*. The boxes *b, b, b*, are furnished with longitudinal slits or openings at their outer side, for the purpose of admitting the tongues of the opposite wing or flap of the bag. It will also be seen, that the sliding-rod *e*, has catches or projections formed on its under side, whereby the tongues of the opposite wing are retained in their place, until the sliding-rod *e*, is drawn on one side, so as to present a plain surface. Fig. 19, represents a cross section of the carpet bag fastening, closed; and the dotted lines in this figure represent the wing or flap, which carries the tongues, as withdrawn from the catches, when the bag is open. *

It will be obvious to any intelligent person, that this description of lock fastening may, with very little modification, be also applied to portmanteaus, trunks, and other similar purposes; its principal advantage being, that any moderate length may be secured by one sliding-rod, furnished with as many fastenings or catches as may be thought necessary.

The patentee claims, First,—the arrangement of any number of catches or fastenings, one above another, or in a right line, whereby they may be simultaneously detached or

loosened, in the manner above set forth and explained, or any modification thereof. Secondly,—the employment of a sliding-rod, blade, or any other equivalent mechanical agent, whereby this may be effected, when the same is employed for any of the purposes herein mentioned.—[*Inrolled in the Petty Bag Office, March, 1844.*]

Specification drawn by Messrs. Newton and Son.

To WILLIAM MILLS, of *Foster-lane, in the city of London, glove manufacturer, for improvements in fastenings for gloves and other wearing apparel, and in the mode of attaching the same.*—[*Sealed 16th May, 1843.*]

THIS invention consists in a peculiar construction of button, for fastening gloves and other parts of wearing apparel, and also in a method of securing the same.

In Plate IX., fig. 1, is a section of the button, and fig. 2, a section of the instrument used for securing it to the glove or other article; this instrument, *a*, is inserted through a hole in the glove (marked *b*, in the section fig. 3,) and also through a hole in the strengthening-piece *c*; the button is then placed upon it, and is securely fixed in the manner represented in fig. 4, by means of dies, worked by a screw or other press. Fig. 5, is a vertical section of the screw-press preferred by the patentee, being of the same kind as those ordinarily used for affixing eyelet-holes to wearing apparel.

The patentee claims the mode of forming fastenings and attaching them to gloves and other wearing apparel, as described in respect to figs. 1, 2, 3, and 4.—[*Inrolled in the Inrolment Office, November, 1843.*]

To CALEB BEDELLS, of *Leicester, manufacturer, for improvements in the manufacture of elastic fabrics.*—
[*Sealed 19th February, 1844.*]

THIS invention relates to a mode of manufacturing elastic

fabrics by the employment of looped fabrics, when two fabrics are cemented together with India-rubber.

The patentee says, it is well known that fabrics made by stocking or knitting-frames, and also by warp-frames, or machines where the fabrics made are composed of loops, that those fabrics are not only elastic, but allow of being stretched in opposite directions. From this peculiar quality in looped fabrics, the patentee has discovered that, when cementing two fabrics together with India-rubber, in a manner to obtain the elastic properties of the India-rubber, it is very desirable to employ looped fabrics made in knitting-frames and warp-frames, for by the use of such fabrics they will allow of being extended in opposite directions, or only in one direction, as occasion may require; and that by the elasticity of the India-rubber they will again assume their ordinary state, and, owing to the peculiar character of the fabrics, will not pucker or plait up when they contract, after having been extended.

Plain fabrics are generally proposed to be used, though more or less ornamented fabrics might be adopted; closer made fabrics being preferred to those with open work. Two of such fabrics are to be taken, the one to be for the outer surface, and the other for the inner surface or lining; and, it is proposed to make them of the same degree of substance or fineness, though this is not absolutely necessary, and may be varied according to the desire of the manufacturer. One surface of each fabric is to be coated with India-rubber cement, in the same manner as if it were intended to make the two fabrics, when stuck together, waterproof, as commonly practised when preparing two fabrics with India-rubber, to be stuck together, in order to produce waterproof fabrics: but, in cases where the object is not to obtain a waterproof as well as elastic fabric, only so much India-rubber cement is used to the two fabrics as will cause them to adhere together securely, and become as one fabric. Between these two surfaces of looped fabrics, several strands or tapes of India-rubber in the non-elastic state are to be introduced; that is, strands or tapes of India-rubber which has been extended, as is well understood, and held in the extended state

until it has become set and non-elastic, and these tapes or strands of India-rubber are to be placed more or less close together, in parallel lines, on one of the pieces of fabric, so that by the cement thereon they may adhere. When this has been done, a coating of India-rubber cement is to be applied on to the surfaces of the strands or tapes of India-rubber, in order that they may adhere to both surfaces of the fabric between which they are enclosed. The India-rubber on the two surfaces of fabric being in a proper state, as is well understood, when sticking two fabrics together by means of India-rubber, (the one fabric having the strands or tapes of India-rubber thereon) they are to be brought together, and pressed so as to become as one fabric; then, by applying heat, the strands or tapes of India-rubber may be rendered elastic, and they will contract themselves and the two surfaces of fabric. Owing to those fabrics being looped fabrics, made by knitting or by warp frames, they will not, by the contraction, become puckered or plaited up; hence it will be found that elastic fabrics of this description will be very valuable for elastic boot-tops, for bands and straps, and for a variety of articles where this peculiar property of elasticity without puckering is considered desirable.

When it is desired that the combined fabric should be thoroughly waterproof as well as elastic, then the tapes or sheets of extended India-rubber used will extend completely over the surface, between the two fabrics; by which means, and the India-rubber cement used in sticking the same to the fabrics, the combined fabric produced, when rendered elastic by heat, will both be rendered elastic and thoroughly waterproof.

In some cases, when causing two surfaces to adhere together by India-rubber, the elasticity may be only required at one part for a certain length, and at others only at intervals, leaving intervals, without elasticity, produced by India-rubber strands or tapes; in which cases, the India-rubber strands or tapes will only be introduced between the two surfaces of fabric, at those places where it is desired that the elasticity should be.

In some cases, the patentee proposes, in place of applying the strands or tapes of India-rubber between two surfaces of looped fabrics, to work the India-rubber strands into one of the fabrics, when making it in the machine, as is well understood, and then to cause another surface of fabric to be stuck to the one containing the India-rubber strands, by means of India-rubber cement, and then, by heat, to afford elasticity to the strands of India-rubber contained in the combined fabric, which, however, is a more costly mode of production, and not materially different from that above described. It is not absolutely necessary that the India-rubber strands, or tapes, or sheets, should be stretched out and set, to render the same non-elastic before they are introduced between two fabrics, though it is believed to be the most convenient process; the object of the invention being to obtain cemented fabrics by employing the peculiar property of elasticity, and capability of extension and contraction of looped fabrics, combined with the properties of elasticity of India-rubber.

The patentee states, that, in some cases, he uses only one looped fabric, combined by cementing with a woven fabric, not looped, in which he employs the woven fabric containing India-rubber strands, and rendered elastic thereby, as is well understood, and cements thereto a looped fabric. And he further remarks, that he is aware various fabrics have before been cemented together by means of India-rubber, and therefore makes no claim to the simple act of cementing fabrics together by India-rubber; nor does he claim the rendering fabrics generally elastic by means of India-rubber, various means having been resorted to for such purposes. But he does claim the mode of manufacturing elastic fabrics by employing looped fabrics, combined by cementing with India-rubber in such a manner as to obtain the elasticity of the India-rubber conjoined with the yielding or extending and contracting properties of such looped fabrics.—[*Inrolled in the Inrolment Office, August, 1844.*]

To JAMES CONNELL, of the city and county of Dublin, Gent.
for his invention of certain improvements in the manu-
facture of candles, and candle-wicks.—[Sealed 24th No-
vember, 1843.]

THE object of this invention is described as consisting in making or constructing the wicks of candles, so that the burning of the candles is improved, and they are prevented from guttering. In Plate VIII., various descriptions of wicks are shewn, the improvements in which consist, firstly,—in taking an ordinary plaited or other wick, consisting of any convenient number of strands, and plaiting or braiding round the same, as shewn in figs. 1, and 2;—8 strands are preferred for the external plaiting, but a greater or less number may be made to answer the purpose. *a*, in fig. 1, represents an internal wick, or gut, made by plaiting, and *b*, is the external one. In fig. 2, the internal gut *a*, consists of a cord or number of threads, arranged side by side, as in an ordinary wick, and the external plaiting or braiding is effected in the same manner as in fig. 1. It is evident that any other arrangement of threads may be employed for making the internal gut, or cord, but it is not necessary to give any further examples, as any cotton-wick manufacturer will be able to apply such other internal cords without further explanation; the claim made under this head, is plaiting or braiding round an internal cord, or gut, composed of a number of strands, arranged and combined in any convenient manner, either by plaiting, twisting, or otherwise, according to the will of the manufacturer.

The second improvement consists in forming a wick of three or more strands, and in which one strand is of much less substance than the others. This wick is shewn at fig. 3, and the small strand is composed of two or three threads twisted together, similar to sewing cotton. The peculiar novelty in this wick, is employing two strands, of equal or nearly equal substance, and a third of a much less substance.

The third improvement is shewn at fig. 4, which is a diagram of the top of a braiding machine. In one of the

rose-heads which work the spindles, an additional spindle *d*, is fixed; this spindle carries a single thread *c*, similar to sewing cotton or thread, and when the machine is at work, the spindle *d*, revolves round the centre of the rose-heads, and consequently passes round each strand separately, as it comes to a particular point of the rose-head. The wick produced by this arrangement of the braiding-machine is shewn at fig. 5, in which the single thread is seen at *c*. The patentee claims this description of wick, and also the application of the additional spindle and bobbin *d*, to the plaiting or braiding-machine for making the same.

The fourth part of the invention consists of an improvement applied to the ordinary plaiting or braiding-machines, as shewn in fig. 6, in which the entire machine is made to revolve round a centre *f*, but the guide-pulley *e*, is stationary, and by this means the wick has a particular set or twist given to it, as it is being made. The same object may be effected by causing the guide-pulley *e*, to travel round the rose-heads, the machine remaining stationary. The patentee claims, putting a set or twist into the wick, by causing either the braiding-machine, or the guide-pulley *e*, to travel round, while the wick is being made or produced.

The fifth improvement consists in laying the loose or extraneous fibres of the yarn, of which candle-wicks are made, by passing the yarn over a flame of gas, or otherwise singeing off the said fibres. The same object may also be effected by passing the yarn through water, very slightly sized, but the singeing operation is preferred. The loose and extraneous fibres on the *outside* of candle-wicks have been removed by singeing, but the patentee's object is to singe off, or otherwise lay, or remove the loose fibres in the *interior* of the wick, so as to render the same more porous, and allow the tallow to flow up more freely to the flame. The claim is, therefore, confined to singeing off, or otherwise laying the loose or extraneous fibres of the *yarn* before it is manufactured into candle-wicks.—[*Inrolled in the Petty Bag Office, May, 1844.*]

Specification drawn by Messrs. Newton and Son.

To BRYAN CORCORAN, of Mark Lane, in the city of London,
gentleman, for certain improvements in the grinding of
wheat, and other substances,—being a communication.—
[Sealed 25th August, 1843.]

THE nature of this invention consists in providing means for the admission of air between the grinding surfaces of two mill-stones, ordinarily employed in flour mills, and thereby keeping the corn or other material to be ground, and also the face of the stones themselves, constantly cool. The manner in which this object is to be effected is represented in Plate VIII. ; fig. 1, being a top view of the upper mill-stone, with certain additions to and alterations made therein, for the purposes aforesaid ; fig. 2, an under view thereof ; and fig. 3, a vertical section on the line A, B, of fig. 1. C, is the mill-stone ; D, the eye-hole, and E, the cross ; F, is an iron case, which encircles the mill-stone, and rises above it to the height shewn in the vertical section, fig. 3 ; it is open at top, but has a solid bottom *a*, which rests on the top of the mill-stone, and a collar *b*, by which it is attached to the cross E, so that it may revolve along with the stone. G, G, are four radial vanes, which extend from the collar *b*, to the inner circumference of the upper part of the case, and are inclined forwards in the direction in which the mill-stone revolves. H, H, are four openings made through the bottom *a*, of the case, and the stone beneath, immediately before the vanes G, G, G, for the admission of the air between the grinding surfaces. As the stone and case revolve, the air is driven down through these apertures by the resistance it meets with from the vanes. K, K, are guide plates for the purpose of directing or inclining the air into the openings *h, h*.

The patentee does not restrict himself to any number of vanes, or openings in the stones and case, nor to any particular shape to be given to the same, but reserves to himself the right to vary them at pleasure, so long as the peculiar system of action before described, is not essentially departed from ; he claims the method, above described, of admitting air between the grinding surfaces of mill-stones, for the pur-

pose of keeping cool the said surfaces, and the materials ground by them.—[*Inrolled in the Inrolment Office, February, 1844.*]

To CHRISTOPHER NICKELS, and BENJAMIN NICKELS, of York-road, in the county of Surrey, manufacturers, for improvements in the manufacture of elastic fabrics, and in rendering elastic fabrics less elastic.—[Scaled 19th February, 1844.]

THIS invention relates to the fabrics manufactured in that description of frame-work knitting machinery, wherein the loops are taken off the needles by what are termed “ticklers;” and which fabrics are produced by lapping two threads or yarns on the same needle, so as to form what may be called a double fabric. It consists, firstly, in rendering these fabrics more elastic, by the introduction of transverse strands of India-rubber; and secondly, in rendering them less elastic, by the insertion of non-elastic yarns or threads.

The India-rubber is either covered or uncovered, and is introduced into the fabric in the non-elastic state; being afterwards made elastic by the application of heat. Sometimes the India-rubber and the non-elastic thread are inserted in the same fabric, either alternately, or in any other order that may be preferred. The India-rubber, or the non-elastic thread, when used alone, may be introduced at every course, or at such intervals as the operator may think requisite. In some cases, in place of inserting the India-rubber while the fabric is being made, draw-threads, or wires, with eyes in them, are introduced, to draw the India-rubber in after the fabric has been taken out of the machine; these arrangements admit of the fabric being dyed, or subjected to other processes, such as fulling and milling, when woollen fabrics are produced; but in the latter case the draw-threads must not be of felting fibres.

The India-rubber, or the non-elastic threads, may be introduced into ornamental as well as plain fabrics; if desired, the fabrics may be made with two threads at those places

only where the India-rubber or non-elastic thread, is inserted; the other parts being manufactured with a single thread.

Although two thread-carriers are preferred to be used, when manufacturing the double fabrics, yet the yarn may be placed on the needles by hand; and when the front and back surfaces of the fabric are to be of the same description of yarn, a single-thread carrier (working under the ticklers) may be employed to make the double fabrics, by passing twice across the machine for each course, in the same manner as if two threads were used.

The patentees, in concluding their specification, state that they are aware of India-rubber, and strands of non-elastic yarn, having been introduced into knit fabrics, when working with one thread; they do not, therefore, claim the introduction of India-rubber or non-elastic strands into knit fabrics generally; their invention being confined to those fabrics where two threads are employed.

They claim, Firstly,—the mode of making elastic fabrics, by introducing strands of India-rubber, transversely, into the description of double knit fabrics herein described. And, Secondly,—the introduction of strands of non-elastic yarn into the description of double knit fabrics herein described.—
[Inrolled in the Inrolment Office, August, 1844.]

To MOSES POOLE, of Lincoln's Inn, in the county of Middlesex, Gent., for improvements in dyeing,—being a communication.—[Sealed 21st March, 1844.]

THIS invention consists in preparing coloring matters for dyeing fabrics, by mixing them with oils, alcohol, essences, and spirits, and then applying them to the fabrics in the manner hereafter described.

Two methods of conducting the preparation of the colors are adopted by the patentee: the first is, to dilute with an essence or oil, coloring matters, some of which are soluble, or, at least, may be chemically separated; and the second is, to dilute the insoluble coloring matters with alcohol, or a mixture of alcohol and essence, or oily material.

In order to render the fabrics soft and pliable, they are submitted to baths of alkali or soap, mixed with linseed oil, in the proportion of ninety-two grains of the former to two pounds of the latter, and, when thoroughly dry, they are in a fit state to be dyed: this operation may be repeated after they are dyed; but it is quite unnecessary.

Three modes of dyeing fabrics are proposed by the patentee: The first consists in diluting the coloring matters with essence of turpentine, and immersing the fabric therein as many times as are requisite to produce the desired tint: the smell of turpentine is afterwards removed from the fabric by exposure to the air. The second mode consists in applying the coloring matters to one or both sides of the fabric, by hand; for this purpose, the fabric is stretched, and fixed upon a table of marble or other suitable material, and the coloring matter, having been diluted with one of the above vehicles, is applied with a brush or other instrument. The third method consists in employing mechanical means to expedite the process, and render the work more regular; this is effected by passing the fabric between rollers, revolving in opposite directions, and at the same time applying the coloring matter with a brush. The fabric may be pressed on planks or metal plates; or, sometimes, a plank and roller is used, and the coloring matter is caused to penetrate the fabric by moving the roller over it.

In all cases, the coloring matter is used in a cold state. Any organic or mineral colors may be employed, according to the brightness of color required. When articles that have been previously dyed are to be operated upon, they should be thoroughly cleaned before being re-dyed.

The patentee claims the mode of coloring or dyeing fabrics, by the use of coloring matters, diluted with spirits or essences, with oily or fatty matters, or with alcohol, either alone, or mixed with the oily matters, whether operating upon the whole or part of the surface of the fabric; and also for fabrics that have been previously dyed, so that the brightness of the color may be restored, and the fabrics have the appearance of new ones.—[*Inrolled in the Inrolment Office, September, 1844.*]

To JAMES HARTLEY, of *Wear Glass Works, Sunderland, glass-manufacturer, for improvements in the manufacture of glass.*—[Sealed 6th July, 1843.]

THIS invention consists, firstly,—in a peculiar method of heating cylinders of glass, after they are split, in order to flatten them; secondly,—in an improved flattening stone; thirdly,—in a new construction of bed, to receive the glass which is to be ground or polished; and fourthly,—in the admission of air into the furnace in which the “nose” of crown-glass is heated, before “flashing.”

With respect to the first head of the invention, the patentee states, that, according to the present construction of flattening furnaces, the workman, when about to flatten a number of glass cylinders, first places one cylinder in the furnace to heat; he then removes it to the flattening stone, and places another in the furnace on the right-hand of the flattening stone, and so on, placing a fresh cylinder to the right of the stone for every one that is taken off it, in order that one cylinder of glass may be heated and be ready to supply the place of the glass which has been flattened and removed from the stone. But the fire, being on the left-hand of the flattening stone, and consequently some distance from the cylinder to be heated, catches one side of the cylinder, causing it to fall over, or partly flatten, while the other side retains something like its former shape. Now, as the cylinder is moved to the flattening stone, and its hotter surface necessarily approaches the fire, it is likely to be burned in that part, while sufficient heat is given to the other part to cause it to fall. To remedy this, the patentee employs a rotary stone, on which the cylinders to be flattened are successively placed, before being removed to the flattening stone, whereby the workman is enabled to turn the less heated side of the cylinder to the fire, before removing it to be flattened. This stone is of a circular form, about ten inches in diameter, and is mounted on an axle, which turns in suitable bearings, thus allowing the workman to turn the stone, with the cylinder of glass upon it, as he may desire.

The second part of the invention consists in making a number of small holes (about the eighth of an inch in diameter) through the flattening stone, to permit the air between the glass and the stone to escape. By this means the resistance which the air under the glass now gives to the flattening process, will be obviated, and the glass will lay more even on the stone; any marks that the holes may occasion, can be removed by the after process of grinding and polishing.

The third part of the invention refers to the grinding bed, and consists in substituting, in lieu of sand, plaster of Paris, or other substances now employed, a layer of sheet India-rubber, about three-eighths of an inch thick, as a bed for receiving the plate or sheet-glass which is to be ground or polished. When, in cold weather, the surface of the India-rubber bed becomes hard, it will be necessary to warm the surface before the glass is laid thereon.

The fourth head of the invention consists in an improvement in the furnace employed for heating the nose of crown-glass, before it is introduced to the flashing furnace. At the opening of this furnace, where the nose of the glass is applied, called the "nose-hole," there is a strong rush of flame, caused by the air which is admitted to the furnace under the ignited fuel, but with the flame a quantity of dust and prejudicial vapours are carried, which have the effect of injuring the surface of the glass. To obviate this defect, the patentee proposes to introduce a current of air at the top of the ignited fuel, and thus prevent the rising of the dust to the nose-hole. The furnace employed is similar in all respects to those now in use, with the addition of means for introducing air in thin streams above the fire-place. For this purpose, on each side of the furnace, a chamber is made, which opens into a tube coming from the exterior of the glass-house, to admit atmospheric air; these chambers open into the furnace just above the fuel, and by means of dampers the supply of air to the fire may be regulated.

The patentee claims, Firstly,—the improvement in the flattening kiln by the application of a stone, capable of rotating horizontally, for successively receiving the cylinders

of glass to be flattened, before they are moved on to the flattening stone; Secondly,—employing a flattening stone, perforated with numerous holes, as above stated; Thirdly,—the application of India-rubber for holding sheets or plates of glass to be ground or polished, as above described; and Lastly,—the mode, before described, of constructing furnaces used for heating the nose of crown-glass, previous to introducing the glass to the flashing furnace.—[*Inrolled in the Inrolment Office, January, 1844.*]

To WILLIAM GODFREY KNELLER, of Wimbledon, in the county of Surrey, chemist, for improvements in the preparation of zinc, and in combinations of zinc with other metallic bodies.—[Sealed 14th March, 1844.]

THIS invention consists in purifying zinc by the employment of melted lead, and, by the use of such purified zinc, forming combinations with copper and other metals of a more useful character than can be obtained with zinc in its ordinary state.

The zinc and lead are melted together (by preference, in equal quantities) and, after being well stirred, the impurities that rise to the surface are skimmed off; powdered charcoal is then thrown on the surface, to prevent oxidation, and the metals remain in a melted state for about three hours, when the lead will have descended to the bottom of the vessel, leaving the purified zinc floating at the top; the charcoal and other impurities are then removed from the surface, by skimming, and the zinc is drawn off through a pipe in the side of the pot. The patentee generally uses a melting pot similar to those used for melting 14 cwt. of lead, but rather deeper, and puts into it 7 cwt. of zinc and 7 cwt. of lead.

When it is desired to combine a small portion of the zinc with the lead, so as to form an alloy, the metals are not allowed to stand for three hours, as above; but, after an hour has elapsed, the greater part of the zinc is drawn off, leaving a thickness of about an inch upon the lead, which, as it cakes, in cooling, is skimmed off, and the lead remaining will be

found to be combined with zinc. The zinc, that has been drawn off, contains a certain quantity of lead, which may be separated by keeping it in a heated state.

For making alloys with copper and other metals, zinc is used from which the lead has been completely separated.

The patentee claims the mode, herein described, of preparing zinc, by retaining that metal melted with lead, and allowing the lead to separate, as herein described. And also, manufacturing alloys of such purified zinc with other metallic bodies.—[*Inrolled in the Inrolment Office, September, 1844.*]

To PETER WARD, of West Bromwich, in the county of Warwick, practical chemist, for an improvement in combining matters for washing and cleansing.—[Scaled 4th March, 1844.]

THE object of this invention is to combine glue or gelatine, and mucilage, with soda or potash, in such a manner as to render the compound suitable for washing and cleansing purposes.

The mode of forming the compound, preferred by the patentee, is as follows:—By means of edge-stones, or other machinery, a quantity of soda-ash of commerce is ground with a solution of glue (formed by dissolving one hundred-weight of glue in forty-five gallons of water) into a thick paste or dough, which is spread on the floor of a room to dry; after four hours have elapsed, it is turned with a shovel, and then allowed to remain for ten hours longer, when it is again turned, and left for about ten hours more, or until it is quite dry; after which it is passed through a sieve of four meshes to the inch. Although soda-ash is preferred by the patentee, soda in other states may be used: and likewise potash may be substituted for the soda.

The above matters may also be obtained in a combined state, by dissolving the glue and alkali in water.

When mucilage is to be used, instead of, or with glue or gelatine, a thick jelly is made from linseed, or linseed oil-cake, and, after the insoluble matters have been strained off,

it is mixed and ground with the alkali, in the same manner as the dissolved glue, or gelatine.

The patentee states, that he does not claim the combining animal gelatinous matters with alkali, generally; his invention requiring that the animal gelatinous matters which may be employed should be converted into glue or gelatine; but he claims the mode of preparing matters for washing and cleansing, by combining glue, or gelatine, and mucilage, with soda or potash, by grinding, and mixing them mechanically, or by solution, as described.—[*Inrolled in the Inrolment Office, September, 1844.*]

To JOHN SYLVESTER, of Great Russell-street, Bloomsbury, in the county of Middlesex, engineer, for improvements in applying heat to brine, and other matters, contained in vessels.—[Sealed 13th December, 1843.]

THE object of these improvements in heating brine, and other matters, as stated by the patentee, is to obtain regulated and constantly-uniform temperatures above 212° Fahr.; and, for this purpose, he causes a column of fluid (by preference, water) to act upon the fluid used as the medium or means of transmitting heat to the brine or other matters. According to the height of the column, so will be the temperature maintainable in such fluid; and this temperature may be varied, from time to time, by increasing or diminishing the height of the column; which is effected by turning a cock at the bottom of the pipe containing it. The vessel containing the brine, or other matter, is placed within another vessel; and they must both be sufficiently strong to resist the pressure of the column of fluid necessary for maintaining the required temperature; a space is left between the two, of from two to three inches, for containing the fluid on which the column acts; and under the outer vessel is a suitable furnace or fire-place.

A column of water, of from thirty-two to thirty-four feet high, will allow of a temperature of about 250° Fahr. being maintained; hence, the pipe should be of that height for

processes requiring a temperature approaching the one just mentioned; and when greater degrees of temperature are required, a higher column will be necessary. A force-pump should be applied to the pipe, so as, by forcing water into it, to increase the column of fluid therein, and thus admit of a higher temperature being maintained.

The patentee claims the mode of heating brine, and other matters, in vessels, by applying a column of fluid, so that it may act, by its pressure, on the fluid medium with which it is connected, and to which heat is to be applied, in combination with other apparatus, as herein described, in such manner as to obtain and maintain desired temperatures, above 212° Fahr., without subjecting the vessels employed to greater pressure than is due to the column of fluid.—
[Inrolled in the Inrolment Office, June, 1844.]

ON THE LAWS RELATING TO LETTERS PATENT FOR INVENTIONS.

No. XIX.

THE PATENT LAWS OF SWEDEN AND NORWAY.

THE first legislative enactment in Sweden and Norway, for the protection of new and useful inventions, was passed in the reign of the late King, in the year 1819; but, as that law was found to be imperfect, and susceptible of considerable improvement, a new law was prepared, which received the royal assent towards the end of the year 1834. This latter Act has made various important alterations in that of 1819, and has, in fact, in a great measure superseded it. It will only be necessary, therefore, to lay before our readers the more recent enactment, that being the one upon the authority of which all proceedings connected with patents for inventions are founded. No mention in the law is made of any tax upon patents, nor of any expence attending the issue of these documents: it may be as well, therefore, to state, that the principal expence incident to obtaining patents in Sweden and Norway, arises from the preparation of the specification and drawings, together with certain small official fees, and the cost of publishing the invention in the newspapers, as prescribed by

the law. The following is a translation from an official copy of the law, which was promulgated on the 13th December, 1834:—

We, CHARLES JOHN, by the grace of God, King of Sweden and Norway, &c. &c. Know ye, that, in consequence of suggestions or propositions made by our Representatives at the present Diet, for certain additions to and alterations in the present law touching letters patent for inventions, (stat. Charles John, Apr. 28th, 1819,) in order to bring the same more in accordance with the laws of other countries on similar subjects, and having permitted this subject to come under our royal consideration: We have been pleased, through this amended Act, to decide, direct, and ordain, what it will be necessary for persons to do and observe, who may be desirous of obtaining exclusive privileges for their inventions or improvements in the arts and manufactures, which are denominated Patents.

SECTION I.—Patent-right insures the exclusive advantage and liberty, during a certain number of years, limited by the patent, to the patentee himself, or to the patentee through others, to put into practice and receive the benefits from an invention, by working or manufacturing, or by vending to others the right of working or manufacturing, the invention for which the patent is granted, and also to vend, or cause to be vended, the produce of the same invention, which produce shall be marked with the name, signs, or marks of the patentee, or of the person or persons to whom the patentee has granted the right to work his invention.

SECT. II.—As a general rule it shall be observed, that patents cannot be granted for a principle only, so as to insure to the patentee the exclusive right to the use of that principle in all its various forms and adaptations; but only to make use of it in the manner, or for the purpose or purposes, which are determined, described, and explained in the specification of the patent.

SECT. III.—Patents may be obtained:—

1. For new inventions in the arts or manufactures.
2. For improvements upon inventions already in use, on condition that the improved invention does not infringe upon any patent or patents already in existence for the same invention.

3. For inventions which are known and used in other countries, but are not yet introduced into this kingdom.

Patents shall not, however, be granted, if such invention is so simple, or can so easily be understood, that it may be manufactured and brought to work by any person, merely from some printed description of the same invention.

SECT. IV.—The longest terms for which patents shall be granted are,—For new inventions, 15 years; for improved inventions, 10 years; for inventions introduced from abroad, 5 years. These terms may be altered, and a shorter time granted, in either class, in proportion to the presumed value of the invention for which the patent is to be obtained; and although the longest term of a patent for an invention which has been introduced from abroad, is mentioned above to be five years, the grant for such patent may however be extended to ten years, in cases when it can be proved, either that the invention is of great importance, or that the importation of it from another country has been attended with considerable risk, trouble, and expence.

SECT. V.—Patents may be obtained by any person of well-known character, residing in Sweden and Norway. They may also be granted to inhabitants of foreign countries, on condition that, before the end of one year from the date of the patent, they shall either themselves be established and naturalized in this country, or they shall, within the same period, have transferred their patent to a person or persons who are subjects of this country.

SECT. VI.—Petitions for the grant of patents shall be presented to our Board of Commerce, and in them it shall distinctly be stated whether the invention is entirely new; whether it is an improvement upon an invention already in use; or if the invention is introduced from abroad; also for how many years the petitioner prays for the patent to be granted. A true description or specification of the invention shall accompany the petition, together with explanatory drawings and models, when necessary for the illustration of the specification. If the petitioner be prevented from presenting the specification at the same time with his petition, then such fact shall be stated in the petition. The Board shall, in that case, allow the petitioner one month for preparing his specification. The patent shall not, however, be granted until the specification has been presented; and the petition shall

be rejected, if the petitioner fails in presenting his specification within the time thus prescribed.

SECT. VII.—When the petition praying for a patent, prepared in compliance with Sect. 6, and accompanied with the specification and the necessary drawings and models, has been presented within the time prescribed, then our Board of Commerce shall immediately grant the patent, which, as enacted by our Board, will contain,—

1. A copy of the specification.
2. The period for which the patent is granted.
3. The duties devolving upon the patentee, as prescribed by this Act.
4. The rights and advantages assured to the patentee by the patent.

A copy of the specification, with drawings or models, shall be deposited by the patentee with our Board of Commerce; liberty being given for any person to examine the same.

In the patent will also be stated,—

1. That the patent does not guarantee that the invention is new, and not before known or used in this country; neither that the invention can be applied with success or advantage.
2. That every person has a right to oppose the patent within the time prescribed in this Act.

SECT. VIII.—When more than one petition for a patent shall be presented for the same invention, then the Board shall grant a patent for the same to him, who has been the first in petitioning the Board for the same patent.

SECT. IX.—As soon as a patent has been granted, the Board shall make it known to the public, by a written notice being posted up in the anti-chamber to the Board, stating the date of the patent.

SECT. X.—When a patent has been granted, it is the duty of the patentee, within two months from the date thereof, to make it publicly known, by causing the whole of the specification to be inserted or advertised, three different times, either in the official newspaper (the *Stats-Tidning*), or in the Mail and Inland newspapers (*Post* and *Inrikes-Tidningar*).

SECT. XI.—Should any person be in a condition to prove, that

an invention for which a patent has been granted, was known and put into operation in this country previously to the date of the petition for the same, or that the patentee, in order to obtain a longer term for the patent than he is entitled to, has stated in his petition that the invention was *new*, when, in fact, it is only an improvement upon an invention previously known and used in this country, or that the same invention has been introduced from abroad; any such person, objecting to the validity of such patent, and intending to proceed against it, shall, within six months from the day the specification was advertised the third time in the State's newspaper, present his petition to the Board of Commerce, in order to begin proceedings for opposing the said patent.

SECT. XII.—Suits or proceedings, as mentioned in the previous or 11th Section, shall be decided by arbitrators, to the decision of whom our Board of Commerce shall refer them, after the petitions have been filed. These arbitrators shall be five in number, two of whom are to be chosen by the complainant, and two by the defendant or patentee. The fifth arbitrator shall afterwards be elected by these four. If, in the election of the fifth, two persons shall receive an equal number of votes, then it shall be decided by lot which of the persons shall be elected. The arbitrators shall thereafter immediately proceed to give their decision, against which no appeal can be made.

SECT. XIII.—Any complainant proceeding against a patent shall, within two months from the filing of his petition, present to our Board of Commerce, in writing, the declaration and decision of the arbitrators. If the necessary inquiries are of so extensive and complicated a nature, as to prevent the declaration from being made out before the expiration of the two months, and if the complainant shall, in a petition to the Board, have stated the circumstances by which the delay has been occasioned, then the Board shall consider, and decide, whether or not any prolonged term above the two months may be granted. Should the complainant fail, within the prescribed time, to present to the Board the decision and declaration of the arbitrators, or omit to petition the Board for an extension of the time for presenting it, then the Board shall declare the suit to be rejected; unless complainant be in a condition to prove, that the delay has been caused by the defendant, in which case the Board shall fix a time, within which, under a penalty, the defendant shall be bound to

proceed. If the declaration of the arbitrators is made out and presented to the Board within the time prescribed, and if the said declaration states, that the invention for which the patent is granted, is not new, but was known and used in this country previous to the date of the petition for the same patent; or if the declaration of the arbitrators states, that the patentee has erroneously set forth the nature of the invention, and that he has thereby obtained a longer term for his patent than he is entitled to; in such cases the Board shall proceed according to the directions given in the 19th and 20th Sections of this our decree.

SECT. XIV.—When a patent is opposed and proceeded against, the patentee shall not be prevented from using or working his invention during the time the proceedings are pending; neither shall the patentee be prevented from using his patent during the time before the expiration of which proceedings for opposing his patent can be entered upon.

SECT. XV.—If the patent shall not be opposed within the time prescribed in Sect. XI., the patentee shall have, use, and exercise the full advantage and right of his patent, on condition that he obeys the directions and prescriptions given in this our royal decree.

SECT. XVI.—Every patentee shall, within two years from the date of the patent, bring his invention into operation. Should the invention be so complicated, that the above time is insufficient for completing it, then it should be so stated in the petition for the patent, when the Board will consider, whether an extension of the time can be granted or not. When such prolongation is granted, the extended term shall be stated in the patent. Every patentee shall also, until the patent expires, be obliged once every year to prove to our Board of Commerce, that the invention is in full operation.

SECT. XVII.—Any patentee may, in case of infringement upon his patent, seek a remedy by an action at law for damages. If the verdict be in his favour, then a fine shall be inflicted upon defendant, the first time of one hundred rix-dollars; and, for every repetition of the offence, two hundred rix-dollars; the half for the benefit of the patentee, and the other half for the benefit of the poor of the parish where the defendant is residing. The value of all articles or goods thus manufactured or sold by the defendant, shall also be made good by him to the patentee.

SECT. XVIII.—Patents and patent rights shall be considered as lawful property. Patents and patent rights shall be hereditary as lawful property. Patents and patent rights may, by means of any lawful transaction, be transferred, or made over, to any well-known person or persons, residing and naturalized (if foreigners) in this country; but such transaction shall first be petitioned for, and receive the sanction of our Board of Commerce. Every patentee shall, in the exercise of his invention, be entitled to the same advantages and privileges which are granted to manufacturers in general.

SECT. XIX.—Patents are void :

1. If they are not published or advertised in the State's newspaper within the time prescribed. (Sect. X.)
2. When, in case of an action at law, the arbitrators shall decide that the invention is not new, or that it has been previously known and used in this country; or, that it is so simple, that it may be executed and brought to work by any person, merely from information gathered from some general printed description.
3. When, in case of an action at law, the arbitrators shall decide, that the patentee has erroneously set forth the nature of the invention, and thereby obtained a longer term for his patent than he is entitled to.
4. When a patentee, within two years from the grant of his patent, shall not have proved to our Board of Commerce, that the invention is in operation. (Sect. XVI.)
5. If a patentee omits, once every year, to state and prove to our Board of Commerce, that the invention is in operation; and, in case the patentee should be a foreigner, if he does not, within one year from the grant of the patent, establish and naturalize himself in this country; or, if he has not, within the same period, made his patent over to some person, who is a subject of Sweden.

SECT. XX.—When a patent has become void, as also when a patent is expired, information or notice thereof shall be inserted or advertised in the State's newspaper by our Board of Commerce, stating the patent to be void, or expired (as may be), and reference is to be made to the description or specification of the patent, which was advertised or published by the patentee in that paper.

SECT. XXI.—When, in this our royal decree, the conditional terms, upon which certain duties shall be discharged, are expressed in months, it is to be understood, that every month shall be reckoned to consist of thirty days.

SECT. XXII.—This, our royal decree, shall enter into force or operation at the beginning of next year, 1835.

CHARLES JOHN.

Stockholm, Dec. 13th, 1834.

EXTENSION OF PATENT RIGHTS.

DURING the past Sessions of Parliament an Act was passed, giving greater powers to the Privy Council, and regulating certain proceedings that come under the cognizance of the Judicial Committee. By the following clauses, extracted from this Act, it will be seen that the Privy Council have now the option of granting an extension of a patent, for any term not exceeding fourteen years, from the expiration of the original grant; and also, a disclaimer and memorandum of alterations may be entered by the proprietor of a patent, whether he be the patentee, or the proprietor by purchase, or otherwise.

An Act for amending an Act passed in the Fourth Year of the Reign of His late Majesty, intituled An Act for the better Administration of Justice in His Majesty's Privy Council; and to extend its Jurisdiction and Powers.

WHEREAS the Act passed in the fourth year of the reign of his late Majesty, intituled *An Act for the better Administration of Justice in His Majesty's Privy Council*, hath been found beneficial to the due administration of justice: and whereas another Act, passed in the sixth year of the said reign, intituled *An Act to amend the Law touching Letters Patent for Inventions*, hath been also found advantageous to inventors and to the public: and whereas the Judicial Committee, acting under the authority of the said Acts, hath been found to answer well the purposes for which it was so established by Parliament; but it is found necessary to improve its proceedings in some respect, for the better dispatch of business, and expedient also to extend its jurisdiction and powers.

And whereas it is expedient, for the further encouragement of inventions in the useful arts, to enable the time of monopoly in

patents to be extended in cases in which it can be satisfactorily shewn that the expence of the invention hath been greater than the time now limited by law will suffice to reimburse; be it enacted, That if any person, having obtained a patent for any invention, shall, before the expiration thereof, present a petition to Her Majesty in Council, setting forth that he has been unable to obtain a due remuneration for his expence and labour in perfecting such invention, and that an exclusive right of using and vending the same for the further period of seven years, in addition to the term in such patent mentioned, will not suffice for his reimbursement and remuneration, then, if the matter of such petition shall be by Her Majesty referred to the Judicial Committee of the Privy Council, the said Committee shall proceed to consider the same after the manner and in the usual course of its proceedings touching patents; and if the said Committee shall be of opinion, and shall so report to Her Majesty, that a further period greater than seven years extension of the said patent term ought to be granted to the petitioner, it shall be lawful for Her Majesty, if she shall so think fit, to grant an extension thereof for any time not exceeding fourteen years, in like manner and subject to the same rules as the extension for a term not exceeding seven years is now granted under the powers of the said Act of the sixth year of the reign of His late Majesty.

Provided always, and be it enacted, That nothing herein contained shall prevent the said Judicial Committee from reporting that an extension for any period not exceeding seven years should be granted, or prevent Her Majesty from granting an extension for such lesser term than the petition shall have prayed.

And whereas doubts have arisen touching the power given by the said recited Act of the sixth year of the reign of His late Majesty in cases where the patentees have wholly or in part assigned their right; be it enacted, That it shall be lawful for Her Majesty, on the report of the Judicial Committee, to grant such extension as is authorized by the said Act and by this Act, either to an assignee or assignees, or to the original patentee or patentees, or to an assignee or assignees and original patentee or patentees conjointly.

And be it enacted, That in case the original patentee or patentees hath or have departed with his or their whole or any part of his or their interest by assignment to any other person or persons, it shall be lawful for such patentee, together with such assignee or assignees, if part only hath being assigned, and for the assignee or assignees, if the whole hath been assigned, to enter a disclaimer and memorandum of alteration under the powers of the said recited Act; and such disclaimer and memorandum of such alteration, having been so entered and filed as in the said recited Act mentioned, shall be valid and effectual in favour of any person or persons in whom the rights under the said letters patent may then be or thereafter become legally

vested; and no objection shall be made in any proceeding whatsoever on the ground that the party making such disclaimer or memorandum of such alteration had not sufficient authority in that behalf.

And be it enacted, That any disclaimer or memorandum of alteration before the passing of this Act, or by virtue of the said recited Act, by such patentee with such assignee, or by such assignee as aforesaid, shall be valid and effectual to bind any person or persons in whom the said letters patent might then be or have since become vested; and no objection shall be made in any proceeding whatsoever that the party making such disclaimer or memorandum of alteration had not authority in that behalf.

And be it enacted, That any new letters patent which before the passing of this Act may have been granted, under the provisions of the above-recited Act of the sixth year of the reign of His late Majesty, to an assignee or assignees, shall be as valid and effectual as if the said letters patent had been made after the passing of this Act, and the title of any party to such new letters patent shall not be invalidated by reason of the same having been granted to an assignee or assignees: provided always, that nothing herein contained shall give any validity or effect to any letters patent heretofore granted to any assignee or assignees where any action or proceeding in scire facias or suit in equity shall have been commenced at any time before the passing of this Act, wherein the validity of such letters patent shall have been or may be questioned.

Provided always, and be it enacted, That in the case of any matter or thing being referred to the Judicial Committee, it shall be lawful for the said Committee to appoint one or other of the clerks of the Privy Council to take any formal proofs required to be taken in dealing with the matter or thing so referred, and shall, if they so think fit, proceed upon such clerk's report to them as if such formal proofs had been taken by and before the said Judicial Committee.

Scientific Adjudication.

SOUTH LANCASHIRE SUMMER ASSIZES.

NISI PRIUS COURT.

(Before Mr. Justice Cresswell and a Special Jury.—August 30th and 31st.)

BENTLEY v. FLEMING.

THIS was an action, before a special jury, to try the validity of a patent granted to William Carr Thornton, on the 21st December, 1841, for "certain improvements in machinery or apparatus for making cards for carding cotton and other fibrous substances." The counsel for the plaintiff were Mr. Watson, Mr. Rotch, and

Mr. Webster; and for the defendant, Mr. Knowles, Mr. Baines, Mr. Addison, and Mr. Cowling appeared. In the declaration, the assignment of the patent by Thornton to Joseph Williamson, and a subsequent assignment by Williamson to the plaintiff, were set out.—The defendant pleaded the general issue, and a variety of other pleas, to the effect that Thornton was not the true inventor of the machine; that the invention, at the time of the granting of the letters patent, was not new; and that the parts of the invention claimed as original were useless, trivial, and immaterial for effecting the purpose intended.

Mr. Watson stated the case. The plaintiff was a roller and spindle manufacturer, at Salford; and the defendant was a card-maker, at Halifax; the action was brought by the plaintiff as assignee and owner of the patent, against the defendant, for an infringement of that patent. By law, where the sovereign had granted letters patent to a person, he had the exclusive use of the patent for the period mentioned therein, which was fourteen years. The Crown, when it granted a patent, granted it only to persons who were the first and true inventors, and where the invention was new: these were two questions which would arise in the present case. The patent in question was for a machine for making cards, for carding wool and cotton, one of the most beautiful pieces of machinery, probably, that was ever seen; and the patent machine, of the infringement of which the plaintiff complained, was discovered by William Carr Thornton, of Cleckheaton, in the county of York. In 1837 he turned his attention to making a machine of this kind; he was several years making experiments, but it was not till December, 1841, that he was able to produce a perfect machine for making good cards. During that time he had a mill at Cleckheaton; he was not able to occupy the whole of the mill; and probably, in the course of the present case, it would become a matter of observation, that two persons named Carver and Brierley occupied a part of that mill. [*The learned counsel here proceeded to explain the construction of Thornton's machine, one of which was brought into court in its perfect state, and also one of the machines manufactured by the defendant, which was sometimes called Oddie's and sometimes Carver's machine.*] The parts claimed as new in Thornton's invention were the following:—1st, the carriage or head-work had to travel along a fixed notch-bar; 2nd, the manner of changing or reversing the motion of the carriage; 3rd, the method of raising up the sheet; 4th, the mode of suspending the jaw-frame, for giving the proper angle at which the teeth were to go in; 5th, the invention for giving steadiness to the carriage or head-work; and the 6th part of the invention consisted in simply mounting the crown head upon a metallic spring. The chief difference between Dyer's machine, which was the old machine by which cards were made, and Thornton's machine, was this, that in the latter the motion was given to the carriage or

head-work, whereas in Dyer's machine the motion was given to the jaw-frame, and it passed to and fro, while the head-work was stationary. There was a great advantage in Thornton's machine over Dyer's, which required double the length of Thornton's machine in working. Mr. Thornton, after many failures, succeeded in perfecting his invention in December, 1841, and proceeded to obtain a patent; the money for that purpose being advanced by a gentleman named Williamson. During the time he was making models, and at the time he was perfecting his invention, some persons named Carver were living upon the same premises. The report had gone about the country, that Mr. Thornton was making great progress in the discovery of a new and efficient carding machine, and several persons were anxious to find out what he was doing; but he (Mr. Watson) thought he should be able to prove, that before the date of the patent a machine had never been discovered by any person, the same in principle as the plaintiff's patent machine. From December, 1841, to the 21st June, 1842, the time allowed for specifying his invention, Mr. Thornton's attention was closely directed to the perfecting of his machine, and on that day his specification was duly enrolled. At the latter end of 1842, or the beginning of 1843, some persons, who had surreptitiously or otherwise got into Mr. Thornton's work-shop, and saw what he was about, made some machines like his. He unfortunately fell into difficulties, and was not able to combat with the number of persons who had leagued together in order to defeat his patent; and he assigned the patent to Mr. Joseph Williamson, who had advanced £130 in order to obtain it. In 1843 the patent was sold by Mr. Williamson to Mr. Bentley, who was now the owner and sole assignee of the patent. It would be found, that the persons who were in court to dispute the validity of the patent were in league, and he (Mr. Watson) thought he should prove, by the clearest evidence, that this was a good and valid patent; that the defendant had infringed that patent; and that the plaintiff had a right of action against him. He (Mr. Watson) understood that an attempt would be made to shew that this was not a new invention, that Thornton himself, and a person named Robertshaw, discovered the invention, and used it before the patent was granted; but it would be proved that all the experiments made by Mr. Thornton, previously to obtaining the patent, differed materially in point of principle from the invention which was the subject of this present action. He believed it would also be set up for the defence, that Mr. Thornton, on one occasion shortly before the granting of the patent, received an order from a person named Naylor, to make a machine for him; and that, not having made the machine in a certain time, he allowed Naylor to come to his premises, and work at a machine already set up. It would be proved, however, that the machine he allowed Naylor to use a few weeks before the date of his patent, was essentially different

from the invention for which he obtained the patent. As to Mr. Robertshaw, his attention had been turned to making carding machines, and he had made some progress; but he had not perfected a good machine before the date of the patent: besides, his invention was not similar to that of Mr. Thornton. A gentleman, named Walton, invented a machine, for which he obtained a patent; but that was what was termed a fillet machine, which was a different machine altogether. The public had derived a great benefit from this invention. At the time of its discovery, Dyer's machines cost about £70; but they had since been reduced to £40. It was alleged that the specification was not a correct one. That would be a question for his Lordship; but there was another question,—Was the specification such as would enable a competent workman to make the machine? because that was what it should be. He should call before the jury both persons acquainted with the manufacture of machines and scientific men, who would state that the specification was such as would enable any man acquainted with the manufacture of machines to construct one from the specification. It was a curious thing, that the machine pirated by Carver was to-day called Oddie's machine. All the witnesses would state, that, although the form of the machine varied, its principle was identical with that of the patent machine. The defendant, Mr. Fleming, who was a cardmaker at Halifax, had bought one of the pirated machines, and sent it to a person named Birley, who was employed to make cards for him; and therefore, that he infringed the patent would be proved beyond all doubt. When application was made to him, he offered to pay £10; and it was only when he associated with Mr. Carver, Mr. Goldsworthy, and others who composed this league, that he thought proper to defend the present action. The letters patent, the specification, and the assignment to the plaintiff, were then put in evidence, and the following witnesses were called:—

Mr. William James Pendleton stated, that about seven years ago he went into the service of Messrs. Curtis, Parr, and Walton, card and machine makers, of Manchester. Witness never saw any machine upon the same principle as the plaintiff's before he saw that machine. He considered Carver's, or Oddie's, machine an infringement. Mr. Dyer's machine was called the "long-sheet machine," and the plaintiff's the "short-sheet machine," as distinguished from Mr. Dyer's.

Mr. George Cottam, engineer, stated that he had seen the specification of Thornton's patent, and had compared it with the machine. It was such a specification as would enable a competent workman to make a similar machine. There was a slight difference between the machine and the specification, but not in the principle. The witness then pointed out what he considered to be the infringements complained of in the machine used by the defendant.

Mr. George Birley, of Halifax, stated that he had worked cards for the defendant, Mr. Fleming, upon the machine produced, which Mr. Fleming obtained from Mr. Oddie. They had another machine of the same description before that; but it was taken away.

Joseph Williamson proved that the machine in question was purchased from Mr. Oddie, the manufacturer.

His Lordship remarked, that the purchase of a patented invention was not an infringement.—Mr. Rotch referred his Lordship to the case of *Gibson and Brande* on the point in question.—His Lordship said, in this case he had not found that the defendant procured the making of the machine. Suppose Mr. Oddie had manufactured half a dozen of those machines, and offered them for sale, and the defendant had gone and bought one, would he immediately be liable to an action for infringing the patent?—Mr. Webster: Yes, my lord; because it would be a question whether he did not intend to adopt it, and use it in the way of his trade.—His Lordship: Then would the using in trade make him liable?—Mr. Webster: Not more liable in law, my Lord; it would in equity to damages. I would submit to your Lordship, that it is precisely in the terms of the judgment in the case of *Gibson and Brande*, in adopting an article which the party might have known was a patented invention.—His Lordship: I don't appreciate the value of the argument "intending to use it," only that it is a step towards using it. Then, would using it make him liable to the action? If it would not, then the intention to use it would not make him worse.

After some further conversation, his Lordship said there was evidence for the jury, and the question might go to the jury. Mr. Mordecai Robertshaw, machine-maker, was then called, and stated that his carding machine resembled the plaintiff's in two or three of the parts claimed as original. In cross-examination, however, it appeared that the witness's machine was materially different in some respects at the time Mr. Thornton obtained his patent to what it was at present. At the conclusion of this witness's examination, the Court adjourned to nine o'clock next morning.

The trial of this cause being resumed,

Mr. Watson said, he had, in conjunction with his learned friends, taken the question which arose the previous evening into consideration, as to the general issue, and there was considerable doubt on the subject. It was a matter entirely novel, and there was no decision to guide his Lordship's judgment in the case.—His Lordship said the opinion he threw out was to this effect, that there was some, though very little, evidence of an infringement, and that he did not expect that upon that evidence, if it was not amended at all, the jury would find for

the plaintiff. At the same time there were other issues, and it might be of use to have the verdict of the jury on them.—Mr. Watson said the question was, whether the circumstances amounted beyond all doubt to an infringement.—His Lordship: I quite agree that working constitutes an infringement.—Mr. Watson said, that working, using, making cards, and selling, were infringements; and, therefore, he thought any person who purchased the machine was an infringer.—His Lordship: Yes, but you are in another difficulty, assuming that to be so. I don't think the evidence as it stands, although there may be something to go to the jury, amounts to that.—Mr. Watson said, there was evidence that the defendant offered to pay £10 for the use of the patent, and the evidence of Birley was, that a machine was sent to his premises, and partly put up, but no cards were ever made; but he said it was a 32-inch machine, and what the defendant wanted was a 42-inch.—The Judge: But he repudiated it, and said he would not have it.—Mr. Watson: Yes, but the reason he assigned for it was, that it was too small; and he got a 42-inch machine after the commencement of the action. Now, that was undoubtedly a case of a machine being bought by the defendant.—His Lordship said, there would be this point of law. Assume that he ordered one of those machines, to make such cards as he wanted, 40-inch. If he got it made, he would be guilty of an infringement; and if he gave an order for a machine to be constructed upon the patent principles, and it was constructed correctly, then he would be responsible for it as an infringement of the patent. But then this curious question arose. Suppose he ordered a man to make him a machine of 40 inches, and he made him one of 30 instead. He said it was not according to his order, and he would not have it. Well, then, if it was made according to the patent principle, was he the maker of it? He never recognized it. Mr. Watson said, he recognized it because he said it was not of the proper size. Assume that its being in Birley's possession was the possession of the defendant. It was sent to Birley to be used for the defendant, and it remained in Birley's possession for six months. His Lordship could not say that it was in the defendant's possession, because he repudiated it. There was nothing to fix him as the purchaser. There was nothing to shew, that he ordered the machine. It was probably sent in execution of another order. If it was so, why did he not pay for it? He thought there was something to go to the jury on that point; but, as to the general issue, he considered it must go against the plaintiff.—Mr. Watson: It would be a good usor, I apprehend, to defeat the patent.—His Lordship: No; the making of such a machine might be evidence that the plaintiff was not the first and true inventor. You are in great peril as to the question of fact, whether he ever gave the order for the machine.

The following witnesses were then called :

John Middleton, of Cleckheaton, stated that he was formerly an apprentice of Mr. Thornton, and left him in December, 1841. At that time, Mr. George Carver occupied part of the same mill, and frequently came into Mr. Thornton's premises, and saw the machine which he had been engaged in constructing for about six years. When witness left Mr. Thornton, he went into Mr. Carver's employ, and assisted him to finish a machine similar to the invention of Mr. Thornton. The machine was in a rough state when witness first saw it.—Cross-examined by Mr. Knowles : Thornton sold Mr. Sutcliffe Broadbent a short-sheet machine, before December, 1841. The head-work of that machine traversed instead of the card. The machine now pointed out to me was the machine I saw at Carver's when I went. I now work for Thornton.

Joseph Sellers, machine-maker, stated that he first heard of Thornton's machine being patented in the beginning of 1842. At that time Messrs. Carver and Brierley occupied a part of Thornton's premises, and witness had some dealings with them about patterns. There was a verbal agreement between witness and Messrs. Carver and Brierley, that they were to pay half the expense of the patterns of the machine that Thornton had made up to that time. Witness made the patterns ; but they never had them. Witness made a machine of the same construction as Thornton's, and set the first card on it on the 24th December, 1841. He took the card to Messrs. Carver and Brierley's, when they told him they were bringing out a superior machine to what that card had been set on.—Cross-examined : Before December, 1841, witness was acquainted with the principle of the head-work changing instead of the jaw-frame. He first commenced his machine in September, 1841, and got his ideas from a machine made by Mr. Thornton, which he saw at work in Mr. Naylor's room in Thornton's mill.

Mr. Bennett Woodcroft, of Manchester, stated, that, in his opinion, a person acquainted with making machinery would find no difficulty in making Thornton's machine from the specification.

Mr. Wm. Carr Thornton, the inventor of the plaintiff's machine, stated that, a few weeks before the date of the patent, he allowed Mr. Naylor to have a short-sheet machine on trial, but never sold him any machines until after the patent was obtained. Witness was engaged in constructing his machine from 1837 to 1841, and, before the patent was granted, never heard of any one being engaged in constructing a similar machine. Carver frequently came into witness's premises, while he was engaged in constructing the machine ; and, on one occasion, offered to buy the invention.—Cross-examined : The machine C, now produced, is the machine Naylor had lent him. The word "patent" was put on the machine a few months after the date

of the patent, by witness's direction. It had been in a state to work only five or six weeks before it was lent to Naylor. After the patent was taken out, Naylor bought two or three of the machines.

Mr. Knowles then addressed the jury for the defence. He submitted, in the first place, that the witness Middleton had entirely disproved the novelty of the invention; for it appeared that Mr. Thornton had sold a machine upon the patent principle to Mr. Broadbent, and that he was using it before the date of the patent.—The Judge: I don't know that Broadbent was using it.—Mr. Knowles apprehended it was not necessary to shew that the machine was actually used by Broadbent.—The Judge: I don't know that it is necessary.—Mr. Knowles said, that was one instance, and he apprehended that would be fatal to the plaintiff's case.—His Lordship said, he understood the witness to state, that, although the machine was sold, he could not tell when it was sent to Mr. Broadbent.—Mr. Knowles: I trust your Lordship will ask him.—The Judge: Oh, yes, certainly, if you wish to re-examine him.

John Middleton was then recalled, and stated that Sutcliffe Broadbent, in 1841, occupied a room in Mr. Thornton's mill; and, two or three months before Christmas in that year, he got a machine with a travelling headwork from Mr. Thornton, and witness had seen it at work in Broadbent's room.

William Carr Thornton recalled: Witness sold Sutcliffe Broadbent a machine, with a travelling head-work, about twelve months before the date of the patent; but it differed in many respects from the patented machine, and was never worked: the machine had a loose notch-bar.

Mr. Knowles resumed, arguing that there was no proof that since the date of the patent, the defendant, Mr. Fleming, had been guilty of any act which made him liable upon the invention of Thornton, supposing it to be a valid patent. The question was, had Mr. Fleming been guilty of using this machine before the date of the patent, and before the bringing of the action? The action was brought on the 14th November, 1843. Was there any evidence to shew, that, before the 14th November, 1843, the defendant used the patent at all? It appeared that Mr. Fleming did not make his machines himself, but employed a person named Oddie, who was called into the box to produce the machine, and was dismissed without a single question being put to him. It seemed that Mr. Fleming had his cards worked by Birley; and that Oddie sent to Birley's shop this machine, in February last, two or three months after the commencement of the action. So far the plaintiff's case failed; but then the witness said that there was another machine sent before the commencement of the action, and sent back. There was no evidence of any contract at all, certainly no contract which would compel the defendant to take it. Whether under

contract or not, the jury were not informed ; but it appeared that Oddie sent the machine ; and, the moment Mr. Fleming saw it, he repudiated it, and said he would have nothing at all to do with it. It was never used at all as a carding engine ; and how, in the name of common sense, could there be any usor of the machine on the part of the defendant ? It was not shewn that Mr. Fleming bought it ; it was shewn that he did not buy it, because, although it was sent, it was taken away ; and the counsel for the plaintiff did not venture to ask Oddie a single question as to what induced him to send the machine to Mr. Fleming. Upon the plea of not guilty, therefore, he submitted that the defendant was entitled to a verdict. But he now came to the other points, and he contended that, at the time Thornton's patent was taken out, there was no novelty in the invention. No doubt, a man engaged in perfecting an invention might make experiments in his own workshop, not making them public to the world ; and, when, at length, he took out his patent, he could not be met by the observation, " This is not new, because a year or two ago you had it in use yourself ;" but the case was quite different if a party made his experiments before the world ; and if Mr. Thornton had made his experiments publicly, if he allowed mechanics to come and watch him, and thereby enabled them to make similar machines, and they did make them, then all claim of novelty was entirely gone, and the patent would go with it. If, again, when the patent was taken out, you found other persons making machines upon the same principle, then he had no right to a patent. But the case was still more strong in the present instance ; for, if a party himself made a machine before he took out a patent, if he sold a machine embodying the principle of the patent, and sold it before the time the patent was taken out, then it would be a fraud upon the public to allow him to have a patent for that which he had exercised for his own benefit, and which he had sold to another man. It was monstrous to suppose, that Mr. Thornton could sell a machine embodying the principle of the patent, and then take out a patent, which, if valid, would make the party to whom he had sold the machine guilty of infringing that patent. It was proved by the evidence of Thornton himself, that he had sold a machine embodying the principle of the patent the year before the patent was granted, and therefore the patent was clearly gone. On that ground, therefore, and also on the ground that there was no novelty in the invention, Mr. Robertshaw having constructed a similar machine before the date of the patent, he (Mr. Knowles) submitted that the verdict of the jury must be for the defendant.

His Lordship then charged the jury, and left three questions for them to determine,—1st, Whether the defendant was guilty of an infringement,—and he would be guilty of an infringement if he had procured to be made for him a machine on the patent principle before the action was brought ; but if he ordered

a machine which was not made for him, but one of another size, on the patent principle, which he repudiated, and refused to take, and was not bound to take, because he did not order it, that would be no infringement by him. 2d. As to the novelty of the invention, whether a machine involving one of the principal parts of the invention, namely, the travelling head-work, was sold by the patentee, or lent by him, and publicly used in England before the date of his patent; and, 3d, Whether they thought, from the evidence, that the travelling head-work of the machine sold to Broadbent was substantially the same as the travelling head-work in the machine for which the patent was taken out. Although Thornton might be the first and true inventor, yet, if he had exhibited his invention to the public, or had offered it for sale before he took out the patent, then he had forfeited his right to the patent; and it would not be a new invention, so as to allow him to have the sole benefit of it, if he exhibited it in England before he took out the patent.

The jury having retired to consider their verdict, came into court after six hours' consultation, and returned a verdict for the plaintiff.

Monday, Sept. 2.—In the course of this day's proceedings, Mr. James Smith, one of the special jurors in the case of *Bentley v. Fleming*, tried on Saturday, took occasion to address his Lordship in reference to the verdict which had been returned in that case. He said, three questions had been left to the jury, and their answers to these were in effect a verdict for the defendant. Notwithstanding this, however, the foreman gave a verdict for the plaintiff. He (Mr. Smith) felt quite astonished at this, and said, before he left the box, that that was not the verdict of the jury, but he was so confused at the time, that he could not take the steps he ought to have taken.

Mr. Watson said, he understood that the question was asked on Saturday night, whether the jury gave their verdict conditionally or unconditionally, and they said, their verdict was unconditional—

His Lordship: No, the officer positively declined asking.

Mr. Smith repeated his former statement, and said he could not allow the verdict to go to the world, without making the circumstances known.

His Lordship said, no doubt steps would be taken; but that was not the place.

August 31st, and September 2nd.

CROSSKILL *v.* GROUNSELL.

THIS was an action brought by the plaintiff, Mr. William Crosskill, agricultural implement maker, at Beverly, Yorkshire, against

the defendant, Mr. William Grounsell, who is engaged in a similar line of business at Louth, Lincolnshire, for the alleged infringement of the plaintiff's patent, dated 8th September, 1841,* for "improvements in machinery for rolling and crushing land, and in machinery to be used in the culture of grass land."

The counsel for the plaintiff were Mr. Knowles, Mr. Martin, and Mr. Unthank; for the defendant, Mr. Watson and Mr. Webster.

The instrument which the plaintiff complained had been infringed by the defendant, was called a "Clod-crushing roller," and was said to be a very effective machine for the purpose for which it was designed. The defendant pleaded the general issue; that the plaintiff was not the inventor of the machine; that the invention was not new; and also that it was not accurately described in the plaintiff's specification.

The clod-crusher generally employed previously to this invention, consisted of a number of metal discs deeply notched in their edges, and placed parallel with each other, on a square axis; the whole, therefore, as the machine was drawn over the surface, revolved together, and the notches coming in contact with the clods, broke up and crushed them. Besides these notches, there were placed, on each side of every disc, at the angles of the notches, lateral teeth, with their edges in the direction of the radius of the disc, which teeth acted in the same way with those formed by the notches themselves. It was found, however, that this compound roller injured the headland, in turning, especially when young crops were in the ground; the teeth of the disc at each end of the roller were dragged through the soil, and did considerable injury. To remedy this inconvenience, it occurred to the plaintiff to make the axis circular, instead of square, so that the discs could revolve upon it, each independent of the other. From this there were two beneficial results. The machine could not clog, as the old one was liable to do, inasmuch as the discs, revolving with unequal speed, according to the greater or less obstruction they met with on the surface, any clods which might find their way between them were rubbed out as the machine proceeded. The greatest advantage, however, was in turning on the headland, for, as each disc revolved independently of the others, those at one end of the axis could turn in one direction, and those at the other end in the other direction; by which means, the soil was not at all deranged while the implement was turning. Another improvement introduced by the plaintiff was, in the position of the lateral teeth. Those in the old machine were in the direction of the radius of the disc, and in consequence of the edge of the disc sinking in its progress some

* For report of the specification, see Vol. XXI., C. S. p. 427.

way into the ground, these teeth met the clods with the side rather than the edge. By changing their position, and placing them at a certain angle to the radius, they were found to meet the clod perpendicularly, and the machine was much more effective.

A number of witnesses—machinists, practical farmers, and others—were called on both sides; and their evidence, as to the novelty of the invention, was very conflicting. It was, however, proved that the defendant had made clod-crushers, in which a number of the discs at each end were made to revolve on a circular axis, those in the middle being fastened on a square axis, as before.

For the defence it was contended, that the invention was not new,—that before the date of the patent a similar machine had been used by the defendant on his own farm, and that others had been sold to different individuals. It was further alleged by Mr. Booth, an engineer at York, that he had himself made a similar machine so long ago as the year 1824.

The jury found a verdict for the plaintiff, damages 40*s.*, thereby affirming the validity of the patent, and its infringement by the defendant.

A NOTICE OF SOME IMPORTANT ARTICLES CONTAINED
IN BERZELIUS' "RAPPORT ANNUEL SUR LE PROGRES
DE LA CHIMIE."

*Presented to the Royal Academy of Sciences at Stockholm,
March 31, 1843.*

Variation of the Boiling Point of Water in Vessels of different Materials.—M. Marcet (Ann. de Chim. et de Phys. v. 449) has made a series of accurate experiments upon the variations of the boiling point of water, dependent upon the nature of the vessel in which it is made to boil. The following are the results of his researches:—1st. The boiling point of water in glass vessels is from 100·3° to 102° cent., varying with certain circumstances, more especially with the different kinds of glass. In these cases the temperature of the vapour of water is constantly the same, and some hundredths of a degree lower than when water is boiled in metallic vessels. 2d. Whatever the nature of the vessel in which the ebullition takes place, the temperature of the vapour is always lower than that of the water from which it is generated. This difference in the case of glass vessels is about 1·06° cent.; in metallic vessels 0·15° to 0·20° cent. There is only one exception to this rule, which is, when the interior of the vessel, whether of glass or metal, is covered

with a thin coat of sulphur or gum lac, or any other substance which exercises a repulsion for water; the boiling water and the vapour then have the same temperature. 3d. Contrary to the opinion generally admitted, it is not in metallic vessels that the boiling point is lowest under an increased pressure, but in glass vessels covered internally with a thin coat of the substances mentioned above. 4th. In glass vessels having the internal surface perfectly smooth and free from foreign matter, water and alcohol can be heated several degrees above their boiling point before they enter into ebullition. Water can thus be heated to 105° cent. If the experiment does not succeed, it is because there is foreign matter adhering to the glass. The experiment may be performed successfully with a new vessel, by first heating sulphuric acid in it to 150° cent., then washing it out with pure water.

The Action of Light upon an Iodized Silver Plate, generates a Current of Electricity.—M. Becquerel (Pogg. Ann. lv. 588) has shewn that two iodized silver plates, plunged in water in the dark, afford no current of electricity when connected by a galvanic multiplier,—but that a current is immediately produced when the light strikes the iodized side of one of the plates. The plate receiving the influence of the sun becomes positive.

Nitric Acid.—M. Millon (Ann. der Chim. und Phar. xlv. 109) has made a great number of experiments upon the solvent power of nitric acid upon the metals; and he has discovered that when perfectly exempt from nitrous acid, it possesses only a very feeble solvent power at the ordinary temperature, even upon metals that we know it dissolves with the greatest energy. This is owing to the fact that the nitric acid ordinarily employed contains nitrous acid, although colorless. If nitric acid is deprived of nitrous acid by ebullition, and then added to a metal which it does not dissolve, it is only necessary to add a very small quantity of some nitrite to bring about the commencement of the solution. M. Millon explains this phenomenon by supposing, that the veritable oxidizing agent is nitrous acid,—this acid forming a nitrite with a disengagement of nitric oxide, (part of the acid has been decomposed to oxidize the metal, and from this nitric oxide is the residue,) which becomes converted into nitrous acid at the expense of the nitric acid; the nitric acid in its turn drives the nitrous acid from the newly-formed salt, and in this manner there is constantly a sufficient quantity of nitrous acid, until the whole of the nitric acid becomes saturated, or the metal entirely dissolved.

New Sulphur Acid.—MM. Fordos and Gelis (Ann. de Chim. et de Phys. vi. 484) have discovered a new sulphur acid, which has a singular composition. When to two equivalents of hyposulphite of soda, one equivalent of iodine is added, the iodine

dissolves and affords a limpid and neutral solution, containing 1 at. iodide of sodium and 1 at. of a salt formed of 1 at. of soda, 4 ats. of sulphur, and 5 ats. of oxygen. The two atoms of hyposulphurous acid combine, in this reaction, with the oxygen liberated by the iodine, forming an acid composed of 4 ats. sulphur and 5 ats. oxygen. They have called this bisulphuretted hyposulphuric acid.

Cyanogen.—M. Wöhler has shewn, that when nitrogen gas containing moisture is passed over a mixture of potash and charcoal, cyanide of potassium is formed, but if the gas be dry, no cyanogen is formed.

Combinations analogous to Cyanogen formed by the combination of Boron and Silicon with Nitrogen.—M. Balmain (Phil. Mag. xxi. 270) has described some very interesting experiments, which seem to prove that boron and silicon form with nitrogen combinations endowed with the halogen properties of cyanogen. When a mixture of 7 parts of anhydrous boracic acid and 20 parts of cyanide of potassium are exposed in a well-covered crucible to a white heat, there remains after cooling a porous mass. The proportions of this mixture are calculated in such manner as that the carbon of the cyanide of potassium suffices exactly to reduce the boracic acid in being converted into carbonic oxide. The substance as taken from the crucible is white and porous, and easily reduced into powder. It is infusible and insoluble in cold water and in warm water, in a cold solution of an alkali, in nitric, hydrochloric and sulphuric acids, and in aqua regia. It is not altered by hydrogen at the temperature of incandescence; the vapor of water on the contrary decomposes it at a temperature below red heat—boracic acid, potash, and ammonia, being the products; all those bodies which retain water at an elevated temperature decompose it, as caustic potash, phosphoric acid, lime, &c. By heating the cyanides of the different metals with boracic acid, similar compounds are formed. In heating in the same manner 6 parts of silicic acid, and 13 parts of cyanide of potassium, a brittle porous mass is obtained, which after washing affords ammonia by fusion with caustic potash.

Formation of Ammonia.—M. Rusët (Jour. de Phar. et de Chim. ii. 257) has shewn that a mixture of hydrogen gas and nitric oxide, passed through a tube containing heated peroxide of iron, gives rise to the formation of ammonia; in the space of half an hour, he obtained sufficient to saturate an ounce of hydrochloric acid. The oxide of iron exercises simply a catalytic action, and is not reduced so long as there is no excess of hydrogen.—*Translated for Silliman's American Journal.*

DESCRIPTION OF A NEW GLAZE OR ENAMEL FOR
GLAZING POTTERY, MANUFACTURED WITHOUT WHITE
LEAD, BY MESSRS. HARDTMUTH, BROTHERS, OF
VIENNA.

MESSRS. HARDTMUTH, Brothers, manufacturers, of Vienna, have discovered a method of covering articles of pottery with a very brilliant and solid glaze or enamel, without the employment of white-lead, and without rendering the articles much more expensive than the usual method.

The following statement on this subject was communicated by the manufacturers to the Society of the Grand Duchy of Hesse. The substances employed for this glaze are borax, felspar, and refractory earth. These substances must be severally treated or prepared in the following manner, in order to render them fit for entering into the mixture. The borax, which is the ordinary borax of commerce, must be pulverised and sifted. The felspar, in a crude state, without regard to its purity or whiteness, must be washed in pure water, and afterwards calcined in the fiercest fire that is used in potters' ovens, and finely pulverised. The clay or *argil* is passed through a fine sieve, and afterwards baked to a red color.

Mixture.—Take 50 kilogrammes of borax, 25 kilogrammes of felspar, and 23 kilogrammes of earth, prepared as above mentioned, and mix them carefully in a suitable vessel, until the several properties or natures of these substances can no longer be distinguished. During this time, several cases (*gazette*) of earth are prepared, and lined with a layer of finely-pulverized silica, about 12 or 14 millimetres in thickness; this silica must be previously calcined to facilitate its pulverization, and afterwards converted into a thick paste, in order to prevent the mixture about to be fused from adhering to the case, and to facilitate its removal therefrom. The cases, having been charged, are exposed to the fiercest fire in the oven, where the mass is fritted into a vitreous substance.

Immersion.—The glaze is diluted with water, until a liquid is produced, marking 40° of Beaumé's aerometer. This may, however, be varied, according as the articles are required to be baked at a greater or less degree of heat, and consequently to be immersed more or less. This operation is performed in the ordinary manner, and does not therefore require description.

Baking.—The process of baking is well known to manufacturers: it will be as well, however, here to observe, that the degree of heat which ought to be employed with this glaze, as well as the length of time for baking, must be the same as in establishments where good well-baked pottery is manufactured, but with white-lead glaze, and not like those where, to save the

wood, the baking is imperfectly performed, which augments the danger already presented by these utensils. Although this glaze is much more expensive than that made with white-lead, the inventors, nevertheless, assert, (and which has been verified by a commission appointed for that purpose) that the difference in price for a vessel containing about three pints, does not exceed three centimes (about a farthing).

The Society of Manufacturers of the Grand Duchy of Hesse having appointed a commission to make experiments upon this glaze, the following is an extract from the Report addressed to the Society on the subject:—

“We have made every effort to find materials of the greatest degree of purity possible, in order to repeat the process which had been communicated to us; but, as it is very difficult to procure Bohemian felspar at Darmstadt, and probably in many other places, we have determined to make our experiments with mixtures, the price of which would be about the same as the felspar, and we have consequently chosen the following composition:—100 parts of borax, 20 parts of ordinary potter's earth, 22 parts of white sand of Ueberau, and 12 parts of potash of commerce.

“Two mixtures were made, viz:—No. 1, according to Messrs. Hardtmuth's plan; and No. 2, according to the proportions lastly mentioned; and the two fritted in precisely the same manner. No. 2, vitrified better than No. 1, and our compound appeared to melt somewhat easier than the other. The two frits were afterwards severally passed through the mill, finely pulverised, and mixed with water, and the articles, previously warmed, plunged therein, and lastly baked in the oven with the others.

“The two compounds furnished a fine solid glaze, of a pale reddish yellow color, in which there was very little difference.

“In most cases the glaze acquires the fine color above mentioned; we therefore resolved to make another experiment with a kind of felspar less pure, viz., that which German mineralogists call *Feldstein*, and which is to be met with in beds of porphyry at Darmstadt and other places, and may be easily procured. We chose specimens of this feldstein, of a clear color, that is to say, not containing too large a quantity of iron and manganese, and we made therewith (because of the quantity of silica it contained) the following mixture, 100 parts of borax, 50 of feldstein, 50 of earth, and 4 of calcined soda. With this mixture No. 3, applied as before, a perfect glaze was obtained, the color of which, however, (a greyish brown,) was very inferior to that of the two other mixtures, besides being more difficult of fusion, a defect which is easily avoided by a larger proportion of soda.

“These experiments have sufficiently demonstrated that the recipe from Vienna, as well as the one we have deduced there-

from, in which the use of felspar is avoided, furnish glazes which will bear comparison with the ordinary white-lead varnish used by potters, as regards duration and impermeability to liquids; but, on the other hand, it is to be feared, that the price thereof, even deducting the cost of the borax, which is the principal ingredient, would be too high, as the materials must be fritted, and afterwards passed through the mill, diluted with water, and applied upon articles already baked in the biscuit form; whereas the white-lead glaze ordinarily employed by potters, which, as is well known, consists of equal portions of litharge and sand, or sandy earth, which is mixed in the mill with water, and applied to articles simply dried in the air, saves the combustible which would be employed for fritting and baking the biscuit. At all events it seems to us, and has been already proved by experience, that articles glazed with a soluble glaze, made without white lead, must come to about double the price of ordinary products of the same kind."

Mr. Schneider, jun., manufacturer of pottery at Mayence, also made, a short time ago, before the Society of Manufactures of the Grand Duchy of Hesse, a favourable report upon the pottery glazed without white-lead, sent by Messrs. Hardtmuth to the exhibition of manufactures which took place lately in that town, and has also mentioned their price as an obstacle to their general use; he took that opportunity of communicating to the Society the result of experiments, made by himself, upon a process communicated to him by Mr. Bernagoud, of Mayence, which has for its object the obtaining, at a moderate price, a glaze free from metal, without the use of borax.

The mixture employed for this purpose consists of 100 parts of silica (washed sand of the Rhine), 80 parts of purified potash, 10 parts of saltpetre, and 20 parts of caustic lime, baked, and reduced to powder by a little water. These ingredients are mixed, and afterwards fritted in a crucible or a reverberatory furnace until perfectly fused. The mixture must be stirred several times during the fusion, as at the beginning it swells considerably from the disengagement of the carbonic acid from the potash. The melted mass is poured upon a suitable iron plate, and, after cooling, reduced to a fine powder. The articles are first passed lightly through the oven, and afterwards immersed some time in water, after which the glaze is applied or sifted thereon as evenly as possible; they are then left in the air, and the glaze is baked in the ordinary manner in the oven.

This glaze resists acids almost as effectually as common glass; and, by the addition of smalt or other metallic oxides, it may be readily colored.

Mr. Schneider has also stated, that Mr. Fuchs, of Munich, had recommended his soluble glass as a glaze for pottery, and proposed to plunge the articles first into the solution of glass, and

afterwards to cover them with his dust in a dry state. The liquor, according to his statement, penetrates into the pores of the substance, and increases its consistency. Mr. Bernagoud had, from what Mr. Schneider said, made trials of this soluble glass; but, far from finding its consistency augmented, he remarked that, after a time, the potash became efflorescent, and consequently the soluble glass was not suitable for this purpose.

Mr. Schneider said, in conclusion, that he had also made experiments upon the preparation of glaze without white-lead, by means of dross from smelting furnaces, and that he had remarked that the glaze did not melt until it had attained such a heat as to cause the earth to contract, and that not above one earth in ten would bear this application. Now, as baking at a high temperature deprives the articles of the property of resisting changes of temperature, and as in that case they break easily, it will be seen that the latter glaze is not applicable to ordinary cases.

This result agrees, at least in a general point of view, with those shewn by Mr. Gœrtler, some time ago, before the Society of Manufactures in Darmstadt.

MODE OF COLORING DAGUERRETYPE PICTURES.

BY CHARLES G. PAGE, M.D., PROF. CHEM. COLUMBIA COLLEGE, WASHINGTON.

IN the month of December, 1842, I instituted a course of experiments to determine the effects of oxidation upon the surface of Daguerreotype pictures, and arrived at some beautiful results in fixing, strengthening, and coloring these impressions. Numerous and arduous duties of a public nature have prevented me from investigating the subject as I wished, and I therefore present the facts for others to adopt, as the basis of what promises to be a most interesting course of study and experiment.

First, a mode of fixing and strengthening pictures by oxidation:—The impression being obtained upon a highly polished plate, and made to receive, by galvanic agency, a very slight deposit of copper from the cupreous cyanide of potassa, (the deposit of copper being just enough to change the color of the plate in the slightest degree,) is washed very carefully with distilled water, and then heated over a spirit lamp until the light parts assume a pearly transparent appearance. The whitening and cleaning up of the picture, by this process, is far more beautiful than by the ordinary method of fixation by a deposit of gold. A small portrait fixed in this way, more than a year since, remains unchanged, and continues to be the admiration of persons interested in this art. One remarkable effect produced by this mode of fixing, is, the great hardening of the surface, so that the impression is effaced with great difficulty. I have kept a small portrait,

thus treated, unsealed and uncovered for over a year, and have frequently exposed it in various ways, and rubbed it smartly with a tuft of cotton, without apparently injuring it; in fact, the oxidized surface is as little liable to change as the surface of gold, and is much harder.

As copper assumes various colors, according to the depth of oxidation upon its surface, it follows, that if a thicker coating than the first mentioned can be put upon the plate, without impairing the impression, various colors may be obtained during the fixation. It is impossible for me to give any definite rules concerning this last process, but I will state, in a general way, that my best results were obtained by giving the plate such a coating of copper as to change the tone of the picture, that is, give it a coppery color, and then heating it over a spirit lamp until it assumes the color desired. I have now an exposed picture treated in this way at the same time with the two above mentioned, and it remains unchanged. It is of a beautiful green color, and the impression has not suffered in the least by the oxidation. Should this process be perfected, so as to render it generally available, it will be greatly superior to the present inartistical mode of stippling dry colors upon the impression; for the color here is due to the surface of the picture itself. For pure landscapes, it has a pleasing effect, and by adopting some of the recent inventions for stopping out the deposit of copper, the green color may be had wherever desired. In some pictures a curious variety of colors is obtained, owing to the varying thickness of the deposit of copper, which is governed by the thickness of the deposit of mercury forming the picture. In one instance a clear and beautiful ruby color was produced, limited, in a well-defined manner, to the drapery, while all other parts were green. To succeed well in the first process, viz., that for fixation and the production of the pearly appearance, the impression should be carried as far as possible without solarization, the solution of the hyposulphite of soda should be pure, and free from the traces of sulphur*, the plate should be carefully washed with distilled water, both before and after it receives the deposit of copper,—in fact, the whole experiment should be neatly performed, to prevent what the French significantly call *taches* upon the plate, when the copper comes to be oxidized.—*Journal of the Franklin Institute.*

* The presence and deposit of sulphur, is a fault of most of the hyposulphite of soda of commerce, and it is the action of this sulphur upon the silver that puzzles so many Daguerreotypers, by clouding, staining, and marking the plates in various ways. It may be obviated by repeatedly filtering the solution, or by keeping it in lightly-corked bottles a long time before it is used.

In addition to the above I may state, that exposure of the coppered picture to the vapour of hydrosulphuret of ammonia, produces sometimes a pleasing effect, but usually spoils the impression.

LIST OF REGISTRATIONS EFFECTED UNDER THE ACT FOR PROTECTING NEW AND ORIGINAL DESIGNS FOR ARTICLES OF UTILITY.

1844.

- Aug. 28. *John Harcourt Brown*, of Stokes Cottage, Ramsgate for a safety horse-shoe.
28. *William Lea*, of Horsley-fields, Wolverhampton, for a double-action mortice-bolt.
31. *Tylor & Pace*, of London-fields, Hackney, for a detector envelope.
- Sept. 3. *Thornhill Warrington*, of 66, Upper Berkeley-street, Portman-square, for valves, glazed and unglazed, for ports, &c.
5. *J. Whitmee*, of 70, St. John's-street, Clerkenwell, for a mill for grinding drugs and groceries.
10. *George Jones*, of Walsall, Staffordshire, for a design for a perforated-edge tooth-brush, with waxed back.
10. *Charles Gatliff*, of Coleman-street, London, for an improved escritoire.
11. *John Russell*, of Greenock, for an improved sugar-vacuum pan.
12. *Henry Clement*, of Bath, for a chimney-guard and ventilator.
13. *Charles Godfrey Jarvis*, of New Church-street, Lisson-grove, for a bird-cage fountain and seed supplier.
13. *Mark & Lumb*, of Leeds, for an improved form of machinery for fulling woollen-cloth.
13. *William S. Villiers Sankey*, of Caroline House, Hampstead, for a self-protecting envelope.
14. *Frederick Benjamin Geithner*, of 40, Fleet-street, Birmingham, for a metal steady for window-frames.
16. *Samuel Messenger & Sons*, of Birmingham, for a design for raising the cotton-wick in vesta-lamps by a grooved wheel pressing against the cotton.
17. *William Mason*, of Great Bourton, near Banbury, for a drill for agricultural purposes.
18. *E. Rose*, of Ogley, Staffordshire, for an expanding scuffle or stubble-plough.
19. *Thomas Robinson*, of Ripon Iron Works, Ripon, for a novel form of clod-crusher.

- Sept. 19. *Joseph Taylor*, of Southampton-street, Pentonville, for a portable apparatus, with self-acting friction-band, spring, or crip, for escape from elevated places, in cases of fire, &c., and for lowering goods or persons generally.
21. *George Thompson*, of Woodstock, for a design for the formation of a glove.
21. *George Kershaw*, of Wilderness-row, Clerkenwell, for an improved leaf and pamphlet-holder.
24. *William Peirce*, of Siddal's-road, Derby, for "Peirce's sash-fastener."
24. *Webster & Son*, of Cornhill, London, for the "Ortho-chronograph, or accurate guide to the time-keeper."

List of Patents

That have passed the Great Seal of IRELAND, to the 20th of September, 1844, inclusive.

To John George Bodmer, of Manchester, in the county of Lancaster, engineer, for certain improvements in grates, furnaces, and boilers; and also in manufacturing and working iron and other metals, and in machinery connected therewith.—Sealed 3rd August.

Thomas Southall, of Kidderminster, in the county of Worcester, druggist, and Charles Crudginton, of the same place, banker, for improvements in the manufacture of iron and steel.—Sealed 26th August.

Wilton George Turner, of Gateshead, in the county of Durham, Doctor in Philosophy, for the manufacturing of salts of ammonia and cyanogen from a substance never before applied to that purpose.—Sealed 26th August.

Joseph Martin Kronheim, of Castle-street, High Holborn, in the city of London, engraver, for improvements in stereotyping,—being a communication.—Sealed 30th August.

James Fenton, of Manchester, in the county of Lancaster, engineer, for an improved combination or alloy, or improved combinations or alloys of metals, applicable to various purposes for which brass and copper are usually employed in the construction of machinery,—being a communication from a foreigner residing abroad, and improvements made by himself.—Sealed 20th September.

List of Patents

Granted for SCOTLAND, subsequent to August 22nd, 1844.

- To Joseph Martin Kronheim, of Castle-street, Holborn, in the city of London, engraver, for improvements in stereotyping,—being a communication from abroad.—Sealed 3rd September.
- Robert Ferguson and John Clark, both of the city of Glasgow, in the county of Lanark, for an improvement in printing and calendering.—Sealed 4th September.
- James Pillans Wilson, of Belmont, Vauxhall, in the county of Surrey, Gent., for improvements in treating fatty and oily matters, and in the manufacture of candles.—Sealed 4th Sept.
- François Stanislas De Sussex, of Bethnal-green, in the county of Middlesex, chemist, and Alexander Robertson Arrot, of Torrington-square, in the same county, chemist, for improvements in the recovery of manganese, and in making bleaching powder.—Sealed 4th September.
- James Smith, late of Deanston, now of Queen-square, London, civil engineer, and William Gairdner Jolly, residing in Endrick Bank, parish of Drymen, and county of Stirling, Scotland, for certain improvements in the form of tiles for draining, in implements for manufacturing thereof, and in the modes of manufacture.—Sealed 4th September.
- John Lionel Hood, of Old Broad-street, in the city of London, Gent., for an improved composition or mixture of metals, applicable to the manufacture of sheathing for ships and other vessels, bolts, nails, or other fastenings,—being a communication from abroad.—Sealed 9th September.
- Peter Ward, of Oldbury, in the counties of Salop and Worcester, late of West Bromwich, in the county of Stafford, practical chemist, for an improvement in combining matters for washing and cleaning.—Sealed 12th September.
- Edwin Sheppard, of Manchester, in the county of Lancaster, builder, for certain improvements in machinery or apparatus for planing, sawing, and cutting wood and other substances.—Sealed 13th September.
- John Beare, of St. John's Wood, in the county of Middlesex, civil engineer, for certain improvements in engines or machines for raising or conveying water and other fluids.—Sealed 18th September.
- James Petrie, of Rochdale, in the county of Lancaster, engineer, for certain improvements in steam-engines.—Sealed 19th September.

New Patents

SEALED IN ENGLAND.

1844.

- To James Pillans Wilson, of Belmont, Vauxhall, Gent., for improvements in treating fatty and oily matters, and in the manufacture of candles. Sealed 29th August—6 months for enrolment.
- William Brunton, Jun., of Pool, near Truro, civil engineer, for improvements in the manufacture of shovels for mining purposes. Sealed 29th August—6 months for enrolment.
- François Stanislas de Sussex, of Bethnal-green, chemist, and Alexander Robertson Arrott, of Torrington-square, chemist, for improvements in the recovery of manganese, used in making bleaching powder. Sealed 29th August—6 months for enrolment.
- Mark Freeman, of Sutton Common, Esq., for improvements in apparatus called ever-pointed pencils. Sealed 29th August—6 months for enrolment.
- Moses Poole, of Serle-street, Gent., for improvements in pumps,—being a communication. Sealed 29th August—6 months for enrolment.
- James Smith, of Queen-square, London, civil engineer, and William Gairdner Jolly, of Endrick Bank, Scotland, for certain improvements in the form of tiles for draining, in implements for manufacturing thereof, and in the modes of manufacture. Sealed 29th August—6 months for enrolment.
- Frank Fielder, of Old-street, St. Luke's, for certain improvements in wire-work for the manufacture of paper, and the application thereof to such purposes,—being a communication. Sealed 29th August—6 months for enrolment.
- William Newton, of the Office for Patents, 66, Chancery-lane, in the county of Middlesex, civil engineer, for improvements in the means or apparatus for preventing shocks or accidents on railways, or in lessening the dangerous effects arising therefrom; being a communication. Sealed 29th August—6 months for enrolment.
- Pryce Buckley Williames, of Llegodig, Montgomeryshire, North Wales, for certain improvements in the manufacture of artificial stone. Sealed 29th August—6 months for enrolment.

- Jean Albert Palmaert, of Brussels, Colonel of Staff, for improvements in the means of economizing and applying heat obtained from known processes,—being a communication. Sealed 29th August—6 months for enrolment.
- Hippolyte Auguste Richard, of Skinner's-place, Sise-lane, Gent., for a certain improved apparatus for heating and lighting. Sealed 5th September—6 months for enrolment.
- Robert William Sievier, of Henrietta-street, Cavendish-square, Gent., for certain improvements in looms for weaving, and in the mode or method of producing plain or figured goods or fabrics. Sealed 5th September—6 months for enrolment.
- James Pillans Wilson, of Belmont, Vauxhall, Gent., for improvements in treating fatty and oily matters, and in the manufacture of candles. Sealed 9th September—6 months for enrolment.
- George Bucknall Picken, of Crosby-row, Walworth, linen-draper, for improvements in umbrellas and parasols. Sealed 12th September—6 months for enrolment.
- Martin Cawood, of Leeds, in the county of York, iron-founder, and William Pritchard, of the same place, for improvements in power looms. Sealed 12th September—6 months for enrolment.
- John Chanter, of London, civil engineer, and George Lodge, of Leeds, engineer, for improvements in furnaces, fire-bars, hot air generators, and flues. Sealed 12th September—6 months for enrolment.
- James Vibart, of Chilliswood House, Somersetshire, Lieutenant, for certain improvements in the means of obtaining and applying power for working or driving thrashing-machines, mills, chaff-cutters, and other machines or apparatus. Sealed 12th September—6 months for enrolment.
- Henry Cooper, of Royton, Lancashire, cotton manufacturer, for certain improvements in machinery or apparatus to be used for doubling cotton, worsted, and other fibrous materials. Sealed 12th September—6 months for enrolment.
- Elias Robison Handcock, of Rathmoyle House, Ireland, and 16, Regent-street, London, for certain improvements in mechanism applicable to a method of propelling vessels on the water. Sealed 12th September—6 months for enrolment.
- Alfred Simpson, of Farnham-place, Gravel-lane, Southwark, hat-manufacturer, for improvements in the manufacture of hats. Sealed 12th September—6 months for enrolment.

Charles Wearg Clark, of Westbourne Grove, Paddington, surveyor, and James Reed, of Hamworthy, Dorsetshire, brick and tile maker, for improvements in the manufacture of bricks and tiles for chimneys and flues, and for other uses. Sealed 12th September—6 months for enrolment.

James Power, of Threadneedle-street, merchant, for improvements in the manufacture of candles and soap, and in treating a certain vegetable matter for such manufactures, and for other uses. Sealed 12th September—6 months for enrolment.

William Newton, of the Office for Patents, 66, Chancery-lane, in the county of Middlesex, civil engineer, for certain improvements in treating and preparing oil or fatty matters,—being a communication. Sealed 12th September—6 months for enrolment.

Webster Flockton, of the Spa Road, Bermondsey, turpentine distiller, for certain improvements in machinery or apparatus for sweeping or cleansing streets, roads, or ways. Sealed 12th September—6 months for enrolment.

Robert Ferguson and John Clark, of Glasgow, for an improvement in printing and calendering. Sealed 14th September—6 months for enrolment.

Christopher Vaux, of Frederick-street, Gray's-inn-road, Gent., for improvements in apparatus for bathing. Sealed 19th September—6 months for enrolment.

William Birkmyre, of Mill Brook, chemist, for certain improvements in the manufacture of potash and soda, alum, sulphuric acid, and sulphate of soda. Sealed 19th September—6 months for enrolment.

James Francis Pinel, of Skinner's-place, Sise-lane, chemist, for certain improvements in the modes of treating farinaceous substances. Sealed 19th September—6 months for enrolment.

Michael Fitch, of Chelmsford, Gent., for an improved substance for preventing decomposition in provisions, and for the method of manufacturing the same, and of condensing and applying a certain gas or fume to certain perishable articles. Sealed 19th September—6 months for enrolment.

Antoine Vieyres, of Pall-mall, watchmaker, for improvements in the manufacture of cut nails. Sealed 19th September—6 months for enrolment.

William Newton, of the Office for Patents, 66, Chancery-lane, in the county of Middlesex, civil engineer, for improvements in machinery to be employed in the manufacturing of nails, rivets, screws, and pins,—being a communication. Sealed 19th September—6 months for enrolment.

CELESTIAL PHENOMENA FOR OCTOBER, 1844.

D. H. M.		D. H. M.	
1	Clock after the sun, 10m. 26s.	—	Saturn R. A. 20h. 12m. dec. 20.
—	☽ rises 7h. 45m. A.	—	36. S.
—	☽ passes mer. 3h. 9m. M.	—	Georg. R. A. 0h. 14m. dec. 0.
—	☽ sets 11h. 18m. M.	—	43. N.
7 5	♃'s second sat. will em.	—	Mercury passes mer. 22h. 42m.
12	☽ in Apogee	—	Venus passes mer. 20h. 56m.
2 8 28	♃'s first sat. will em.	—	Mars passes mer. 22h. 16m.
13 51	♀ greatest elong. 46. 13. W.	—	Jupiter passes mer. 10h. 9m.
3	Occul. 16 Geminorum, im. 12h. 38m. em. 13h. 35m.	—	Saturn passes mer. 6h. 35m.
	Occul. ♁ Geminorum, im. 13h. 12m. em. 14h. 11m.	—	Georg. passes mer. 10h. 36m.
4 4 29	☽ in ☐ or last quarter	5 57	♃'s third sat. will em.
12	☽ stationary	12 15	♃'s second sat. will em.
5	Clock after the sun, 11m. 57s.	12 38	♀ in the ascending node
—	☽ rises Morn.	16 12 19	♃'s first sat. will em.
—	☽ passes mer. 7h. 10m. M.	17	Pallas greatest Hel. Lat. N.
—	☽ sets 2h. 39m. A.	18 3 16	☽ in ☐ or first quarter
11 2	♄ in the ascending node	6 48	♃'s first sat. will em.
—	Occul. α2 Cancri, im. 12h. 40m. em. 13h. 32m.	14 48	♃ in conj. with the ☽ diff. of dec. 5. 4. S.
6 9 24	♄ stationary	19	Occul. ζ1 Aquarii, im. 7h. 54m. em. 8h. 57m.
7 15 15	♃'s first sat. will em.	20	Clock after the sun, 15m. 10s.
21 20	Vesta in conj. with ♃ diff. of dec. 5. 24. S.	—	☽ rises 2h. 25m. A.
8 2 6	♀ in conj. with the ☽ diff. of dec. 4. 43. N.	—	☽ passes mer. 7h. 44m. A.
9 40	♃'s second sat. will em.	—	☽ sets 0h. 1m. M.
9 10 23	♃'s first sat. will em.	21	Occul. κ Aquarii, im. 6h. 10m. em. 6h. 41m.
9 23 56	♄ in conj. with the ☽ diff. of dec. 6. 25. N.	8 35	♄ greatest hel. lat. S.
10	Clock after the sun, 13m. 2s.	22	Occul. κ2 Piscium, im. 7h. 12m. em. 8h. 27m.
—	☽ rises 4h. 22m. M.	22 7 4	♃'s third sat. will em.
—	☽ passes mer. 10h. 23m. M.	21 20	♃ in conj. with the ☽ diff. of dec. 6. 56. S.
—	☽ sets 4h. 11m. A.	—	Occul. κ1 Piscium, im. 7h. 23m. em. 8h. 14m.
28	♄ in Perihelion	14 51	♃'s second sat. will em.
8 58	♄ in conj. with the ☽ diff. of dec. 6. 21. N.	—	Occul. 16 Piscium, im. 13h. 29m. em. 14h. 10m.
11 11 24	Ecliptic conj. or ● new moon	23 11 44	♃ in conj. with the ☽ diff. of dec. 5. 43. S.
13 10	☽ in Perigee	14 14	♃'s first sat. will em.
12 20	♀ greatest elong.	18 55	☽ in ☐ with the ☉
15	Mercury R. A. 12h. 18m. dec. 0. 1. N.	25	Clock after the sun, 15m. 51s.
—	Venus R. A. 10h. 32m. dec. 9. 5. N.	—	☽ rises 4h. 10m. A.
—	Mars R. A. 11h. 54m. dec. 1. 48. N.	—	☽ passes mer. 11h. 30m. A.
—	Vesta R. A. 20h. 19m. dec. 25. 38. S.	—	☽ sets 5h. 35m. M.
—	Juno R. A. 8h. 55m. dec. 6. 12. N.	8 43	♃'s first sat. will em.
—	Pallas R. A. 16h. 38m. dec. 7. 25. N.	26 5 5	Ecliptic oppo. or ○ full moon
—	Ceres R. A. 16h. 50m. dec. 23. 56. S.	—	Occul. ρ2 Arietis, im. 17h. 45m. em. 18h. 16m.
—	Jupiter R. A. 23h. 47m. dec. 3. 2. S.	27 8 35	Vesta in conj. with the ☉
		29	Occul. ω2 Tauri, im. 6h. 10m. em. 6h. 59m.
		29 3	☽ in Apogee
		14 1	♃'s third sat. will em.

J. LEWTHWAITE, Rotherhithe.

THE
LONDON JOURNAL
AND
REPERTORY
OF
Arts, Sciences, and Manufactures.

CONJOINED SERIES.

No. CLV.

RECENT PATENTS.

To JOHN HICK, of Bolton-le-Moors, in the county of Lancaster, engineer, for certain improvements in steam-engines, and in apparatus to be connected therewith, for driving machinery; part of which improvements are applicable to forcing, lifting, and measuring water."—[Sealed 5th December, 1843.]

THESE improvements apply, Firstly,—to that particular class of steam-engines called "rotary engines," and consist in a novel and peculiar construction and arrangement of the working parts of the engine, which, by the application of steam, air, water, or other fluid, produce a rotary motion, with diminished friction: the engines thus made, are equally suitable for stationary, locomotive, or marine purposes. Secondly,—these improvements apply to the construction of slide-valves, employed for the admission of steam into the cylinders of all steam-engines where valves are used; and consist in removing a great proportion of the pressure from the valve-face, by sustaining it on rollers or other bearings, as hereafter shewn and described, and thereby diminishing the friction of the valve. Thirdly,—these improvements apply

to the coupling or connecting steam-engines, or other driving power, with shafts and machinery, and disconnecting the same, in such a manner as to modify the intensity of the first impulse of the driving power; that is, gradually to transmit or withdraw the motion of a primary moving power, to or from machinery, to be started or stopped at intervals; and they consist in a simple arrangement of apparatus (which may be readily modified and adapted to suit the various situations in which it may be employed) for tightening and slackening the friction straps, or slips, ordinarily in use, for stopping and starting machinery, by a more simple and perfect arrangement of mechanism than has hitherto been employed for such purposes, and thus avoiding the inconvenience frequently arising from machinery being thrown suddenly into, or out of gear. Fourthly,—these improvements apply to forcing, lifting, and measuring water, and other fluids; and consist, firstly, in the application to such purposes of a similar construction or arrangement of apparatus, to that above described, as employed for a rotary steam-engine; and, secondly, in a novel and simple arrangement of mechanism, designed to be employed as an hydrometer, or machine for measuring and registering the flow of water, or other fluids.

In Plate X., fig. 1, is a sectional elevation of the improved rotary engine, with the front or side plate removed, in order to shew the working parts of the engine clearly; fig. 2, is a vertical section of the engine, taken in the reverse position, and through about the middle of the engine; fig. 3, is an exterior side elevation of the same; and fig. 4, is a sectional view of the inner cylinder detached, exhibiting the mode of packing the piston therein. *a, a, a*, is an outer case or annular cylinder, bored out perfectly true, having one end or side *b, b*, cast fast, or screwed on by bolts, as may be most convenient. *c, c*, is a smaller annular cylinder, occupying the larger portion of the space within the cylinder or case *a*, as regards its diameter, and made to fit accurately at both ends, and so placed, that one portion of its periphery is always in contact with the outer case or cylinder; to this is connected the driving-shaft *d*. *e, e*, is a loose cover, or end, which may be removed at pleasure, so as to examine the interior working

parts. *f*, is a centre or fulcrum, round and upon which the vane, wing, or piston *g*, *g*, freely revolves, and is packed at its outer extremity with metallic or other packing, so as to prevent the escape of steam, and at its sides, in a swivelling block or packing *i*, *i*; metallic or other elastic packing may also be adapted at the sides, though it is not absolutely necessary, as the cover *e*, *e*, may be ground up, if the vane or piston is lessened by wear. In the upper part of the outer cylinder *a*, *a*, as shewn at fig. 1, are openings *h*, *h*, for the admission or exit of the steam, or other fluid. Each of these openings may be used for either purpose, in order to cause the driving-shaft *d*, to revolve either way; the reversing motion is accomplished by means of the slide-valve *j*, which is to be worked by rods and levers *z*, *z*, as usual. This valve is of further use, in preventing the steam passing from the ingress and through the egress openings at the moment when the vane or piston is moving between the two; the valve is opened and shut at proper intervals, by an excentric fixed on the shaft *d*. The mode of action is as follows:—Steam being admitted by the pipe *k*, through the opening *h*, acts upon such portion of the vane or piston *g*, as is exposed in the excentric space between the two cylinders *a*, and *c*, and thus forces the interior cylinder round, until the vane has reached the exhausting opening, when the steam is shut off by the valve *j*, and so remains, until the vane has passed the entrance *h*; the motion being kept up by the momentum previously given to the fly-wheel *l*, which may also serve as a driving-pulley, if required.

As the peculiar arrangement of the slide-valve constitutes the second feature of novelty, and is equally applicable to all steam-engines, the patentee proceeds to describe them with reference to the detached figures of the valve, which are drawn upon a much larger scale for this purpose. Fig. 5, is a vertical section, taken through part of a steam-cylinder and valve-box, shewing the slide-valve also in section; fig. 6, is a horizontal section of the valve-box, shewing the upper portion of the slide-valve, as seen from above; and fig. 7, is a representation of the interior of the valve-box, shewing the back of the slide-valve complete. *a*, *a*, represents portions of

the box. *b, b*, is the valve itself, having a loose back or cover *c*, to which are attached the rollers *d, d*, by means of the shafts *e, e*, passing over, and secured to the back of the valve. These rollers move with the valve, and bear upon the projecting ledges or rails *g, g*, planed true and parallel with the face upon which the valve slides. *f*, represents a packing ring, which is screwed against any kind of elastic packing, so as to prevent the passage of steam. Thus it will be observed, that a great proportion of the pressure is taken from the valve-face, and is sustained by the rollers *d, d*, bearing or running on the rails *g, g*, and thus diminishing the friction on the valve-face. This valve may be applied in place of the ordinary D-slide, or other valves, at present in use for similar purposes, and in steam-engines of any description.

With reference to the first and second parts of his improvements, the patentee claims the peculiar arrangement and combination of the working parts of the rotary engine, above described, so as to produce a rotary motion. He does not confine himself to its use or adoption as a motive power; but it may also be employed as a pump for lifting or forcing fluids; in which case the openings should be made much larger than when steam, &c., is to be used. He likewise claims its use as a water-meter; for which purpose two vanes or wings should be applied, so as to prevent any water passing without turning the central shaft.

The third part of these improvements is shewn at figs. 8, and 9, which represent the improved driving apparatus as applied to a pair of bevil or mitre-wheels, driving a bleacher's mangle. The main driving-shaft *a*, has the wheel *b*, keyed firmly on, and is working into the wheel *c*, prepared on its back with a suitable projection *d*, and fitted with a pair of ordinary friction-straps *e*, in the usual way, and running loosely on the cross shaft *f*, which has to be put in motion. Instead of the bolts commonly used for tightening the friction-straps on the block at the back of the wheel, there are two screws *g, g*, introduced, with right and left-handed threads, and having a toothed-pinion *h, h*, on the middle of each, working in between two jaws, cast upon the driving-

arm *j*, which arm is keyed fast on the shaft *f*. This driving-arm is fitted with two toothed quadrants *k, k*, gearing into two toothed racks *l, l*, at the nearest point to the centre of the shaft; one end of each of these racks is screwed to a ring *m*, which slides on suitable keys let into the shaft *f*, and is carried round with it when in motion. This sliding ring is moved in and out by the usual levers, &c., used for a common catch-box. When the shaft *f*, and the driving-arm *j*, together with the toothed quadrants, pinions, right and left-handed screws, and friction-straps, attached thereto, are stationary, the wheels only are in motion, the ring *m*, attached to the racks *l, l*, will project out, say, the length of the rack, as shewn in the drawing; then, by forcing up the sliding-ring and racks with the usual levers, motion is communicated through the quadrants to the pinion, and the right and left-handed screws; thereby tightening the friction-straps, and causing the mangle, or any other machine, to which it may be applied, to be gently and gradually put in motion, without any of those disagreeable and injurious shocks consequent on using the common catch-box. This plan is especially adapted for starting bleacher's mangles, calenders, dash-wheels, and all other kinds of machinery where the common friction-straps and catch-boxes are used; and it may be applied to the existing gearing of the before-mentioned machines, with little, and, in some cases, no alteration, further than the substitution of the driving-arm, with its racks, pinions, and quadrants, for the common catch-box. With reference to this part of his improvements, the patentee claims the method of tightening and slackening the friction-straps, now commonly in use, by the toothed-rack, quadrants, and pinion, in connection with the right and left-handed screws, or instead of these racks, quadrants, &c., levers and joints may in some cases be used.

The fourth part of the improvements consists in the construction and arrangement of apparatus constituting an hydrometer or machine for measuring and registering the flow of water, &c., through pipes, as represented in the following figures:—Fig. 10, shews a vertical section; fig. 11, a cross section, and fig. 12, a front elevation of the apparatus. It

consists of a spiral-shaped wheel or hollow drum *a*, which is divided into separate compartments *b, b*, each communicating with a central chamber *c*, of the drum; this drum is mounted upon a fixed stud *d*, in the side of a case or box *e*, in which it can revolve freely, and through an opening in one of its sides, is introduced an inlet pipe *f*, through which the water or other fluid to be measured is brought to the machine. The case *e*, has a water-tight cover *g*, screwed on its top, and is filled with mercury, or some other fluid, specifically heavier than water, as high as the line *l, l*; this level being higher than the top of the central hole in the side of the revolving drum, but below the orifice of the inlet-pipe *f*, through which the water is introduced; an outlet-pipe and cock is brought from any convenient part at the top of the machine, as at *h*, and above the mercurial line *l, l*: this pipe is of a smaller bore than that of the inlet-pipe. Now it will be seen, that when water is introduced into the machine by the inlet-pipe *f*, from a level higher than that of the machine, it will fill the space within the casing above the mercurial line *l, l*, and upon the outlet tap being opened, will exert its pressure upon that chamber of the revolving drum, the inner opening of which is communicating with the orifice of the inlet-pipe *f*, above the level of the mercury *l, l*, the outer orifice of the chamber being below it; and the drum will then begin to revolve in the direction shewn by the arrow, and continue to do so, as the chamber fills with water, until the inner opening of the next chamber rises above the line *l, l*; the previous one having now descended below it, and each opening or chamber thus successively communicating with the inlet pipe *f*, at the centre, will cause the drum to revolve, so long as the outlet-pipe is open to take away the water delivered from the successive chambers as they rise above the mercurial line *l, l*. It is evident that so long as the discharge-pipe is of less bore than the inlet-pipe, no water can pass through the machine without causing it to revolve; and the speed at which it revolves will be in exact proportion to that at which the water is allowed to flow from the discharge-pipe; and when the discharge-cock is closed, the drum will cease to revolve, as the pressure from the inlet-pipes ceases

at the same moment to exert any power upon the inside of the chambers communicating with it.

The mode of registering the quantity of water which passes through the machine is as follows:—Fig. 12, shews this part of the apparatus; a spur-wheel 1, is fixed on the revolving drum, giving equal motion to another wheel 2, the shaft of which projects through a stuffing-box in the side of the outer casing *e*; upon this shaft is a pinion 3, which gives motion to the wheel 4; this wheel has a finger attached to it, pointing to numbers of gallons marked upon the index-plate 5; each gallon passed through the machine corresponding with one gallon marked upon the index.

With reference to this part of the improvements, the patentee does not limit himself to four chambers, as shewn in the drawings, or to the particular form or dimensions of them, or to the shape of the casing in which the drum revolves, or, indeed, to the particular mode of mounting the drum upon a fixed stud, or that of communicating motion from the drum to the index finger outside the machine, as these may be varied in practice, according to the size and proportion of the machine. But he claims the application of a drum, divided into compartments, revolving within a water-tight chamber, containing mercury, or other fluid specifically heavier than water, in such a manner that the drum is made to revolve by the pressure of water or other fluid exerted upon its inner surface, thus causing it to register the quantity of water passing through it.—[*Inrolled in the Petty Bag Office, June, 1844.*]

Specification drawn by Messrs. Newton and Son.

To PHILIP WALTHER, of Angel-court, Throgmorton-street, in the city of London, merchant, for certain improvements in the construction of steam-engines.—[Sealed 12th October, 1843.]

THE class of engines to which this invention relates, are those which act by means of jets of steam, issuing into the air, so as to cause a revolving motion; and which engines

are known by the name of "Brunier's re-action steam gyrator." The improved engine, forming the subject of this patent, consists of two arms, of equal length, fixed upon a horizontal axis, supported by suitable bearings; at the outer end of each arm is a receiver, into which steam is alternately admitted, and discharged therefrom, in successive jets, instead of a continuous stream, as usual in this description of engines. A small reciprocating steam-engine is carried by one of the arms, and is employed to open and close the passages by which steam is admitted into, and discharged from, the receivers; the slides or valves being so arranged, that while steam is admitted into one receiver, the passage for its discharge shall be closed, and the action of the receivers shall, in this respect, be reciprocal. One end of the horizontal shaft is made hollow, and forms a passage for the steam to the engine, cylinder, and receivers; the steam being admitted from the boiler into a steam chamber, on the framework of the engine, in which the end of the shaft enters.

In Plate X., fig. 1, is an elevation of the engine and its framing; fig. 2, is a vertical section; and fig. 3, a front view of the revolving arms, and their appendages. *A*, is the base plate of the engine; *B*, the side framing; *C, C*, the ends of the revolving arms, which are affixed to the horizontal shaft *D*, supported in bearings *E*. The hollow part of the shaft *D*, extends from its end *b*, to the revolving arms, as indicated by the dotted lines *a*, and the end *b*, of the shaft works in a stuffing-box, which forms part of the steam chamber *F*; this chamber is supported by a bracket *c*, attached to the frame *B*, and steam is admitted into it from the boiler through a pipe *j*, furnished with a throttle-valve *k*. The steam proceeds from the hollow shaft *D*, through the tubes *d, d*, into the small chambers *e, e*, and thence into the receivers *f, f*, through the passages *g, g*, which are opened and closed by the slide-valves *i, i*; these valves also open and close the passages *h, h*, for the discharge of steam from the receivers, and are worked by the small steam-engine, above mentioned. *H*, is the cylinder of the engine; *G*, the piston; and *l*, the piston rod, which works through stuffing-boxes *m, m*, at each end of the cylinder, and is elongated, so as to constitute the rods of the

slide-valves *i, i*; its ends passing through stuffing-boxes *n, n*, attached to the receivers, and through guides *o, o*, within the receivers. *p, p*, is a frame, which surrounds and works clear of the shaft *D*, and serves to connect the two portions of the rod *l, l*. A small steam-pipe *t*, provided with a regulating cock *u*, leads from the hollow part of the shaft *D*, to the valve-box *v*, of the small engine, which contains an ordinary *D* slide-valve for opening and closing the induction and eduction passages, as shewn. The rod of this slide-valve has on its outer end a tappet *s*, which enters a slot in a piece of metal *g*, fixed to the frame *p*; the extent of the slot is shewn by the letters *r, r*, and the tappet *s*, when acted on by the upper and lower ends thereof, causes the valve to slide within its box. It will be seen, that by this connection, the action of the slide-valve, and the valves *i, i*, are rendered simultaneous and uniform, and that when the steam is being admitted into one receiver, it is in the act of escaping from the other.

w, is a counterpoise to the small steam-engine, to render the momentum of the two arms equal; *x*, is a pinion, fixed upon the shaft *D*, and communicating motion, through the large spur-wheel *y*, to the machinery required to be driven; or any other description of gearing may be employed for that purpose. The arms revolve within a case *1*, (represented by dotted lines) which is secured to a flange *J*, on the base plate *A*, and has a steam pipe *z*, at its top.

When the engine is to be applied to the purpose of navigation, where it is desirable that the motion of the arms should be readily reversed, the patentee employs four arms, instead of two. In this case, both ends of the shaft *D*, may be made hollow, so that the steam can be supplied to either pair of arms, as required.

Fig. 4, represents a longitudinal section of a modification of the engine. In this arrangement, the same letters of reference are used as in figs. 1, 2, and 3, for the parts which correspond in their action with those previously described. From the shaft *D*, the steam passes through the pipes *d, d*, chambers *e, e*, and passages *g, g*, into the receivers *f, f*, and escapes therefrom through the eduction-pipes *h, h*, which

extend to the exterior of the casing 1, enclosing the engine, and revolve with the casing on the shaft *D*. The passages *g, g,* and *h, h,* are opened and closed by separate valves 1, 1, and 2, 2, and these valves are worked by means of two steam cylinders, *H, H,* bolted on the ends 3, 3, of the receivers. The pistons *G, G,* of the cylinders *H, H,* are fixed on one rod *l,* which passes through the shaft *D,* and through the stuffing-boxes 4, 4; at the extreme ends of this rod are the valves 1, 1, and to it also the valve-rods 5, 5, of the valves 2, 2, are attached, by means of the transverse pieces 6, 6. In the centre of the end 3, of the receivers, is a hole, through which the rod *l,* passes; but the diameter of the rod being less than that of the hole, an annular space is left around it, for the admission of steam into the cylinders *H, H,* to work the pistons *G, G.* A hole 7, is formed in each cylinder, to allow the air to enter, when the piston is moving in one direction, and to escape, when it is returning; so that, in whatever direction the pistons are moving, the air enters one of the cylinders, to occupy the space which would otherwise be a vacuum, while it escapes from the other cylinder, where the piston tends to compress the air. The pistons, after passing the holes 7, 7, at the end of the stroke, compress the small quantity of air remaining in the cylinder; by the elasticity of this compressed air, the returning motion of the pistons is facilitated, and all shocks are prevented. The pistons, with the valves, may, if preferred, be worked by hand, by introducing a lever or other instrument through the slots 8, 8, in the case 1, and causing it to act on the transverse pieces 6, 6.

The engine is intended to be worked with steam at a pressure of from five to six atmospheres.

The patentee claims, as his invention, obtaining the rotary motion of the arms of the engine, above described, by the successive and rapid discharges of steam through orifices such as are represented at *h, h,* in the accompanying drawings; which orifices are made in steam receivers, and governed by valves; the supply of steam, and the reciprocal action of the said valves, being effected and regulated by an arrangement of parts substantially the same with that herein described. And also the employment of a small steam-engine

or engines, attached to one or both of the revolving arms, and so connected and combined with the valves in the receivers as to cause them to regulate the admission of steam into, and its discharge from, the said receivers, for the purpose and in the manner above described. He then says,—“I will here observe, that I have, in the first instance, claimed the manner in which I have constructed the receivers, with their valves, for the supply and discharge of steam in successive instants, separately and distinctly from the claim to the employment of the small steam-engine for opening and closing the valves in the receivers; and this I have done, because I am aware that, by means of tappets or other devices, attached to the framework of the engine, or to the case which surrounds it, the said valves might be made to open and close without the aid of said steam-engine, though not, as I believe, with equal advantage.”—[*Inrolled in the Rolls Chapel Office, April, 1844.*]

To ELIJAH GALLOWAY, of Nelson-square, Blackfriars-road, in the county of Surrey, for certain combinations of materials, to be used as a substitute for canvas and other surfaces employed as grounds for painting; some of which combinations are applicable to other purposes.—[*Scaled 14th February, 1844.*]

THIS invention consists in the application of certain mixtures or compositions to canvas or other woven materials, to be used as grounds for painting, and to the surfaces of walls, &c., as hereafter described.

The mixtures consist of India-rubber, combined with earthy, woody, or fibrous matter, and any insoluble substance capable of being reduced to fragments not coarser than sand or sawdust, and, in some instances, to a fine powder. The India-rubber is prepared by a well-known process (fully described in the specifications of other patents,) of grinding or crushing, in a vessel heated by steam, so as to bring it to a plastic or pasty state; the pulverized matters are then mixed with it, by a process resembling kneading or

rolling, and the mass is reduced to a uniform thickness, by being passed between cast-iron rollers.

The mixtures, prepared in this manner, are to be attached to some other body, by India-rubber cement or other adhesive material; that is to say, if intended to remain fixed, like cartoons or other decorations of walls, they are to be cemented to the walls, ceilings, floors, or other surfaces; but if they are to be moveable, like a painting, they are cemented to canvas, network, or other coarse fibrous fabric. For large paintings, the particles of pulverized matter may be of the coarser kind above mentioned; but for small works, chalk, dried clay, or similar materials, capable of being reduced to fine powder, are employed. When the mixtures are used for covering floors, and are to have ornamental designs painted upon them, finely-powdered cork is mixed with the plastic India-rubber. In cases where they are employed out-of-doors, and exposed to moisture, mouldiness is prevented by the addition, to each hundred pounds of India-rubber, of half an ounce of corrosive sublimate, or other metallic salt which will resist vegetable decomposition.

These mixtures are also intended to be used in ship-building instead of felt, between the copper and planking of the ship; being made in thin sheets, which are cemented in their places, and then coated on the outside with cement, and before this becomes dry, the copper is fixed on in the usual manner. They are also made into blocks or masses of suitable forms, and applied to the purpose of filling the spaces between the timbers or planking of ships; being cemented to the wood, and to each other, so that the whole becomes impervious to water. For boat-building, the mixtures are formed into sheets, planks, or slabs, and used with or without timber courses.

A substitute for floor-cloth is formed, by rolling the material into large thin sheets, the sides of which are cut parallel, and bevilled off to thin edges; these edges are rubbed over with India-rubber cement, and united by causing them to overlap, and then pressing them carefully together; when the cement is dry, the side that is not intended to be printed upon is coated with cement, and a piece of canvas, cloth, or

other woven fabrics applied thereto; the substitute for floor-cloth, thus made, is now ready to be printed on.

For covering roofs, walls, or other surfaces, where it is required to exclude rain and moisture, the material is rolled into sheets, which are cemented to the surfaces to be covered, and to each other.

For paving or covering floors or road-ways, the sheets or slabs are cemented to the "subsurface," and to each other.

The patentee says, in conclusion,—“ I hereby declare that I lay no claim to the invention of any of the mixtures herein referred to, nor to the method of preparing them; such mixtures, and the processes of preparation, being already well known. But what I claim, as my invention, is, their application to the purposes herein described, in the manner I have pointed out; more particularly the cementing the said mixtures to some other body, and to each other, according to the respective purposes to which they are to be applied.”—*[Inrolled in the Inrolment Office, August, 1844.]*

To WILLIAM SHELDON, of Birmingham, in the county of Warwick, japan painter, for improvements in the manufacture of buttons, and in japanner's ware, and articles in substitution of papier-mâché.—*[Sealed 21st February, 1844.]*

THE first part of this invention consists in an improved mode of making buttons. A mixture is made of eight pounds of glue, dissolved in water, six ounces of cotton or flock, six ounces of linseed oil, and three ounces of Venice turpentine; then forty pounds of whiting, or blue-black (or a mixture of those matters), five pounds of lamp-black, and five pounds of fine flour emery, are mixed together; and these two mixtures are combined, forming a composition of the substance of thick dough. This composition is rolled into sheets of from a quarter to half an inch thick, according to the size of button required, and, after remaining for a day, it is cut into discs, with the tools ordinarily used for making horn buttons. Wire or other shanks are now to be applied to the

discs ; the shanks preferred by the patentee are thus formed :

 and after being pressed into the composition, by the aid of pliers, they are turned partly round, so that their projections may be well imbedded in the backs of the discs. The discs are next brought to the form of the intended button, by pressure between dies, and are then coated, by means of a brush, with a composition of white of egg, mixed with Prussian or Italian blue (to color it), and well ground together ; when this is dry, the discs or buttons receive two or three coats of a varnish, composed of naphtha polish, ground with a little Prussian or Italian blue. The buttons are then pressed in cold dies, engraved or not, as in making horn buttons ; after which the rough edges are removed, and a coating of varnish is applied to the edges and back.

Black buttons are produced by the process above described ; but dark-colored ones may be made, by mixing suitable colors with the coatings of egg and varnish, together with or instead of the Prussian or Italian blue. A light drab, or other light color, is obtained, by omitting the lamp-black, and using suitable coloring materials, and more whiting or white-lead ; a corresponding color being also given to the white of egg and varnish. Instead of whiting, other earthy powder, and white-lead, may be employed ; and paper or other fabric may be applied to one or both surfaces of the disc, as hercafter described for japanner's ware.

The second part of the invention consists in improvements in making japanner's ware, and articles in substitution of papier-mâché. The mode of operating is as follows :—Six pounds of glue dissolved in seven gallons of water, twelve pounds of flour, six pounds of sharps (separated from flour), nine pounds of spent hops, four pounds of whiting, and two pounds of finely cut hair, are reduced, by boiling, to a thick paste, which, after it has become cool, is rolled into sheets of the required size for manufacturing trays or other articles. To make a tray, or similar article, a sheet of the composition is placed between two thin sheets of paper, and subjected to pressure, between a pair of moulds or dies, for an hour or more, to cause it to assume the desired shape ;

two thick sheets of paper are now damped, and one is applied to each die ; after which, paste (consisting, by preference, of equal parts, by weight, of flour and glue) is spread over each sheet, and over the thin sheets of paper which enclose the composition, and the whole is subjected to great pressure, between the dies, for about an hour. The tray, thus far made, is then placed between two iron trays, of the same shape, and dried in a stove ; when dry, it is removed from the iron trays, and dressed ; then dipped in oil, and finished in the usual manner of treating japanner's ware.

The following is another method, adopted by the patentee, for making trays and other articles of japanner's ware, or in substitution of papier-mâché :—Six pounds of pulp (made in the ordinary manner), in a stiff state, one pound of sharps, one pound of spent hops, one pound of fuller's earth, and one pound of flour, with or without glue, are mixed with water, so as to form a thick yet fluid composition, which is run on to a sieve (such as is used in making paper by hand), and a sheet, of a suitable thickness for making a tray or other article, is thereby produced. After standing for a few minutes, the sheet of composition is inserted between two felts or flannels, and placed in a press (in this state, when dry, it may be used for making buttons, instead of the ordinary button-board) ; after which, the sheet is taken from between the felts or flannels, and submitted to pressure, between dies, to bring it to the required form ; it is then clamped, or otherwise secured, between two sheet-iron shapes or moulds, and dried in a japanner's oven ; when dry, it is dressed, treated with oil, and finished in the ordinary manner.

The patentee does not confine himself to the materials or proportions above mentioned ; but he claims, Firstly,—the mode, herein described, of making die and pressure-made buttons, by employing a composition of fibrous materials and adhesive matter with other materials. Secondly,—the mode of making japanner's ware, and articles in substitution of papier-mâché, by applying a composition of fibrous materials with adhesive matter, between surfaces of paper, as herein described. Also the mode of making japanner's ware, and articles in substitution of papier-mâché, and button-board

for making buttons, by combining fibrous materials with adhesive matter and pulp, as herein described.—[*Inrolled in the Inrolment Office, August, 1844.*]

To HENRY PERSHOUSE PARKES, of Dudley, in the county of Worcester, manufacturer of chain cables, for improvements in the manufacture of flat pit chains.—[Sealed 14th March, 1844.]

THIS invention consists in a mode of manufacturing that description of chain, commonly known as the flat pit chain, by stamping the links out of metal plates, and connecting their ends by welding.

The plate of iron or other metal for each link is rolled in such a manner as to leave a greater thickness of metal at those parts which are most liable to wear. In Plate X., figs. 1, represent the plate in plan and edge view. The pieces *a, b, c, d, e*, (fig. 2) are then punched out, to form the knuckles of the link; after which the plate is bent into the shape represented in fig. 3; and the ends being then welded together, a perfect link is produced, as seen at fig. 4. The links are connected together by pins or axes *f*, which are secured by nuts, or by "upsetting" both ends thereof, as shewn in the plan view, fig. 5; and, in some cases, to the sides of each link, a plate or link *g*, (fig. 6) is applied.

Fig. 7, is a plan view of a modification of the improved chain, composed of a link *h*, and two links *i, i*, placed alternately; the knuckle joint being produced by the manner of arranging the links, which are formed by rolling a plate of metal, and welding the ends together, as above described, with reference to figs. 1, 2, 3, and 4; but without punching out any portion of the plate: side plates or links *g*, are also employed in the construction of this chain.

The patentee claims the mode, herein described, of manufacturing flat pit chains with welded links.—[*Inrolled in the Inrolment Office, September, 1844.*]

To ANDRE DROUOT DE CHARLIEU, of the Sablonière Hotel, Leicester-square, in the county of Middlesex, Gent., for improvements in rails for railways, and in wheels for locomotive carriages,—being a communication.—[Sealed 20th March, 1844.]

THESE improvements in rails for railways consist, firstly, in applying an angular flange to the side of the rail, to prevent the wheels from running off (the flange being either formed in one piece with the rail, or made separately, and affixed by bolts or pins); and, secondly, in applying to wooden rails, of the same shape, flat metal bands, or strips of iron, in such a manner that the pressure of the wheel shall take place on those parts, so that the ordinary rail will not have to be made so thick.

Fig. 1. Fig. 1, is a transverse section of a rail, the flange *a*, for which is formed separately, and attached to it by bolts. The angle preferred by the patentee for the flange is 105° ; but he does not confine himself thereto. The part *b*, on the top of which is the flange, may be made either of wood or metal; but the flange must be of metal.

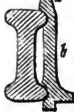

Fig. 2.



Fig. 3.



Fig. 4.



Fig. 2, is a section of a rail made in one piece with its flange; fig. 3, a rail and flange formed separately; and fig. 4, a rail and flange in one piece.

The form of rail to which the flat bands of iron or other metal are to be fastened is represented at fig. 2; the bands may be placed at intervals upon the rail, so that the pressure of the wheel will take place at those parts: the dotted lines in fig. 2, shew the position of the bands; the upper line representing them as placed over the whole of the rail and flange; and the under line indicating the situation of those parts where the friction takes place.

The improvement in wheels for locomotive carriages consists in dispensing with the ordinary flange, which is rendered unnecessary by the use of the improved rails: those sides of

the wheels which press against the flange of the rail are made to correspond with the angles of the flange, or are rounded.

The patentee claims, Firstly,—constructing rails with flanges, when the flange is at an angle to the rail of not less than 93° , whether the flange be a part of the rail, or a separate piece, bolted thereto, as herein described. Secondly,—the application to wooden and other rails of bands of metal, in such a manner that the pressure of the wheel acts upon such bands on the surface of the rail. Thirdly,—dispensing with the flanges on the wheels of locomotive carriages.—*[Inrolled in the Inrolment Office, September, 1844.]*

To CHARLES WILLIAM SPICER, of Portman-square, in the county of Middlesex, Esq., for an invention called the *Nautilus*, or portable life-preserver and swimming-belt, in a communication.—*[Scaled 28th March, 1844.]*

THE swimming-belt, or life-preserver, which is the subject of

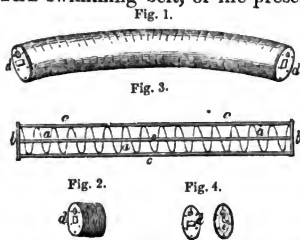

this patent, is shewn at fig. 1, in its distended form; fig. 2, exhibits it in its compressed state; fig. 3, is what the patentee terms a skeleton view, the outer covering being removed; and, at figs. 4, an outside and an inside

view of one of the ends is shewn. *a*, is an elastic helical frame of metal, the terminal coils of which are rivetted to the insides of two broad metal rings *b, b*; to these rings are also secured the ends of the tapes *c, c*, which are likewise attached to each of the coils of the frame; so that the frame cannot be drawn out any further than the length of the tapes, and its coils will be kept at about an equal distance from one another. On each ring *b*, a valve-plate *d*, is fixed, having an opening in it, closed by a valve *e*, which is formed in one piece, with a spring lever, attached to the inside of the ring *b*, (see fig. 4); the covering of the belt is made of

waterproof cloth, and its ends are secured by inserting them between the rings *b*, and plates *d*, when in the act of screwing them together.

The belt is distended by catching hold of the two ends, and pressing the valves *e*, inwards, with the thumbs, so as to admit the air, at the same time drawing out the belt to its full extent; on withdrawing the thumbs, the valves spring back, and effectually prevent the escape of the enclosed air; the belt may then be fastened round the body by means of the spring catch *g*, and hasp *h*. The belt is restored to its original size by opening the valves, and pressing out the air.

The patentee claims "the employment of waterproof air-cases or belts, constructed in the particular manner before described; whereby they can be compressed within so small a compass as to be conveniently portable, and can almost instantaneously be inflated for use, by such manual exertion as persons, under all circumstances, can readily apply. Also the employment of elastic spiral frames in articles adapted to the said purposes; whether the same consist of one continuous spiral only, such as before described, or of two or more such spirals."—[*Inrolled in the Inrolment Office, September, 1844.*]

[A life-preserver, very similar in its construction to the above, was patented in June, 1839, by Mr. Furnival.—Ed.]

To MONTAGU MACDONOUGH, of St. Alban's-place, in the county of Middlesex, Gent., for improvements in spindles, flyers, and bobbins, for spinning, roving, twisting, and reeling all sorts of fibrous or textile substances, and in the application or adaptation of either, or all of them, to machinery, for the same purposes,—being a communication.
—[Sealed 6th January, 1842.]

THE improvements in spindles, flyers, and bobbins, which constitute this invention, are shewn in Plate XII., fig 1, being an elevation of the spindle and flyer; fig. 2, a vertical section of the bobbin, and what is termed the bobbin-carrier; and fig. 3, an elevation of the spindle, bobbin, bobbin-carrier,

&c., as they appear in the spinning-frame. *a*, is the spindle, on the top of which the flyer *b*, is secured, by means of a screw, in order that it may be readily detached; *c*, is the bobbin, and *d*, the bobbin-carrier, consisting of a tube, with a ledge *e*, formed on it, to support the bobbin; the tube *d*, passes through a bearing in the fixed rail *f*, and its lower end works in a bearing in the fixed rail *g*; motion is communicated to it by an endless band, passing around the pulley *h*, fixed upon it, and the bobbin is caused to rotate with the tube, by a projection *i*, on the ledge *e*, entering an opening in the bobbin. The spindle *a*, passes through the tube *d*, and turns freely therein; its lower end working in a bearing carried by the rail *j*, which has an ascending and descending movement, to cause the yarn to be wound properly on the bobbin, in the same manner as is effected by the ordinary coping motion. The spindle is not driven by an endless band, passing around a pulley upon it, as usual; but it is caused to turn by the drag of the yarn, as it passes through the eye of the flyer to the bobbin: friction is applied to the lower end of the spindle, by means of a pulley and weighted cord, or other convenient arrangement.

The patentee prefers that the bobbins should be of larger diameter and shorter than those usually employed: when the bobbins are of considerable diameter, and the flyers wider in proportion, the reeling on to such bobbins will render the ordinary process of reeling unnecessary.

He claims the mode of constructing spindles, flyers, and bobbins, and applying or adapting the same to machinery used in spinning, roving, twisting, and reeling, by so forming spindles and flyers that they turn freely by the draught of the fibres which are receiving twist, and without motion being communicated to such spindles or flyers by a wharve or pulley and endless band, as heretofore; the pulley or wharve and driving-band being only applied to the bobbin, which is so arranged as to turn freely.—[*Inrolled in the Inrolment Office, July, 1842.*]

To THOMAS LAMBERT, of *Albany-street, Regent's Park, in the county of Middlesex, musical-instrument maker, for improvements in the action of cabinet piano-fortes.*—
[Sealed 15th January, 1842.]

THIS invention consists in dispensing with the strips of leather hitherto used for connecting certain parts of the "action" of a cabinet piano-forte, and substituting joints of wire; the wire, constituting each joint, having a screw formed on it, to afford the means of adjustment.

In Plate XII., fig. 1, exhibits the action of a cabinet piano-forte; and figs. 2, are front views of the parts to which this invention is applied, detached from the instrument. The sticker *a*, is attached to the under lever *b*, by a wire *c*, one end of which is screwed into the sticker, and the other end is bent into a hook, and passed through a hole (lined with woollen cloth) in the projection *d*, of the lever *b*. At the upper end of the sticker a leather hinge-joint is applied; but, instead of fastening the hinge-piece *e*, to the hammer-butt *f*, in the usual manner, it is screwed thereto, so as to admit of the sticker being readily removed. The wire *g*, for lifting the damper *h*, is connected with the lever *i*, by bending its lower end, and inserting it into a hole (lined with woollen cloth) in the projection *j*, on the top of the lever *i*; on the upper or screwed end of the wire *g*, is placed a piece of wood *k*, which, by being turned, is elevated or depressed, and the action of the wire *g*, is thus regulated to a nicety. The sticker *l*, that works the damper and check part of the action, is connected with the lever *i*, by the wire *m*, which is screwed into the sticker, and the wire is then bent, and its end passed through a hole (lined with woollen cloth) in the projection *n*, on the under side of the lever *i*.

The object of these improvements is to enable the manufacturer or tuner to regulate the length and action of the above parts with great exactness.

The patentee claims as his invention, Firstly,—the mode of connecting the sticker *a*, with the lever *b*, by means of the wire joint *c*. Secondly,—the mode of connecting the parts *g*, and *i*, by bending the wire *g*, and thus producing a wire

joint with the part *j*, as described. Thirdly,—the mode of connecting the sticker *l*, with the lever *i*, by means of the wire joint *m*, as described.—[Inrolled in the Inrolment Office, July, 1842.]

To ARCHIBALD TRAIL, of Great Russell-street, Bloomsbury-square, in the county of Middlesex, Gent., for an improvement in the manufacture of sails for ships and other vessels.—[Sealed 24th February, 1844.]

THIS invention consists in strengthening sails by the application of bands and cords or lines, crossing each other in several places, so as to sustain the sails, and prevent them from being torn by the action of the wind.

In Plate XI., is a representation of a portion of a sail made according to this invention, where the bolt-rope runs parallel with the selvages of the cloth; but the invention is equally applicable to sails of a triangular or other shape. Parts of three cloths of a sail are shewn, having a bolt-rope *a*, at the edge as usual; *b, b*, are a series of strengthening cords or lines, arranged parallel to each other, in a diagonal direction, on one side of the sail; and *c, c*, are another series of cords, extending in an opposite direction on the other side. These cords are secured to the cloth of the sail by sewing bands of canvas *d*, over them; and the ends of the cords are fastened to the bolt-ropes in the manner shewn: in some instances, where the bands *d*, are made of a very strong fabric, the cords or lines *b, b*, and *c, c*, may be dispensed with.

The ordinary linings and strengthenings of canvas, now commonly used on the "leeches" and middle of a sail, and the reefing-bands, may be used in conjunction with this improvement.

The patentee claims, as his invention, the mode of manufacturing sails, by applying strengthening bands, cords, or lines, in such a manner as to divide a sail into numerous equal, or nearly equal parts, and support the canvas of which a sail is composed at intervals, and thereby give additional strength to sails for ships and other vessels.—[Inrolled in the Inrolment Office, August, 1844.]

To JOHN WRIGHT and RICHARD WRIGHT, both of Richmond, in the county of York, boot and shoe makers, for certain improvements in boots and shoes, and other the like coverings for the feet.—[Sealed 6th July, 1843.]

THE first part of this invention consists in making boots, shoes, &c., from leather prepared in the following manner:—When the skin or hide is taken out of tan, instead of proceeding to sam, shave, and scour it, as usual, the patentees oil the grain with good clean oil, then stuff the fleshy side with a mixture of oil, tallow, and turpentine, and hang it up to dry; after this they sam, shave, and scour it, then stuff it lightly with oil and tallow, and, when again dry, whiten and finish it.

The second improvement consists in dispensing with the welts of boots and shoes, and employing an extension of the upper leather as a substitute.

In Plate XII., figs. 1, and 2, are transverse sections of a thick heavy shoe; fig. 1, exhibiting the mode of connecting the upper leather *a*, and the inner sole *b*, by the stitches *c*, according to this improved method, without any welting, (the extension *d*, of the upper leather being substituted for the welt); and fig. 2, shews the manner in which the extension *d*, of the upper leather is connected with the middle sole *e*, and outer sole *f*, by the stitches *g*.

The third improvement is shewn at figs. 3, and 4, and consists in sewing on a small strip of neat leather, with the stitch that secures the extension of the upper leather to the inner sole; so that when the stitch, which fastens on the outer sole, is passed through the strip of leather, it draws the strip over the stitches that unite the upper leather to the inner sole, thus concealing them, and leaving only one row of stitches to be operated upon by the finishing iron, which method is an improvement in making light or dress shoes.—Figs. 3, and 4, are transverse sections of a light shoe; the former figure representing the method of connecting the upper leather *a*, inner sole *b*, lining *h*, and strip of leather *i*, by the stitches *c*; and the latter figure shewing the manner of securing the upper leather and strip *i*, to the outer sole *f*, by the stitches *g*.

The patentee claims, Firstly, the preparation of the leather, as hereinbefore described. Secondly,—doing away with the ordinary welt, in boots, shoes, and other the like coverings for the feet, and substituting, in lieu thereof, an extension of the upper leather, to which the sole is to be sewn, in the manner above described. Thirdly,—the introduction of the thin strip of neat leather, shewn at figs. 3, and 4, and marked *i*, in the manner and for the purpose hereinbefore described.—[*Inrolled in the Inrolment Office, January, 1844.*]

To WILLIAM GEEVES, of Little Portland-street, in the county of Middlesex, cork and cork gun-wadding manufacturer, for improvements in preparing wood for lighting or kindling fires.—[Sealed 12th February, 1844.]

THIS invention consists in combining several bars or pieces of wood, in such a manner as to leave a space between the adjoining bars, both longitudinally and vertically; so that, when the bars or pieces are lighted, for the purpose of kindling a fire, the flame may move freely in a horizontal and vertical direction.

In the edges or ends of the main bars, or pieces of wood, several saw-cuts or notches are made; any required number of these bars are then combined, by ranging them in a row, at short distances apart, with their notches corresponding, and driving into each set of notches (*i. e.* those in the same line) the edge of a thin and narrow piece of wood, which is of the same length as the mass is required to be. A piece of rag, or paper, saturated with any readily inflammable matter, may be attached to the combined mass, by inserting its edge in one of the notches, previous to driving in the thin piece of wood; and the wood may also be dipped in any suitable inflammable matter.

The patentee claims, the mode of combining bars, or pieces of wood, having saw-cuts or notches, with pieces of wood which have no corresponding saw-cuts or notches, as herein described.—[*Inrolled in the Inrolment Office, August, 1844.*]

To WILTON GEORGE TURNER, of Gateshead, in the county of Durham, Doctor of Philosophy, for his invention of improvements in the manufacture of alum.—[Sealed 8th October, 1842.]

THIS invention consists in the manufacture of alum from felspar rocks, or any other rocks or mineral substances containing silica and alumina, sufficiently free from other substances to be subjected to the process, (which is performed by the aid of potash or of soda: when the former is used it is called potash alum; and when the latter, it is called soda alum). If desirous of making a potash alum, the patentee proceeds by fusing felspar, or other rock or mineral substance containing silica and alumina, with such salts of potash as will yield, when fused at a red or white heat, a uniform glassy substance; this glassy substance, if sufficient potash has been used, is readily decomposed by water. The quantity of the salts of potash required will, in general, be about twice the weight of the mineral substance used, although, under certain circumstances, smaller quantities may answer. The aqueous solution contains silicate of potash, and the insoluble residuum is a light porous substance, similar in chemical composition to the mineral commonly called alæolite; this porous substance is decomposed by sulphuric acid, and forms alum by the separation of its silica. If the above process be performed with the salts of soda, instead of potash, the light porous substances obtained will be similar in chemical composition to the mineral known commonly as nepheline; and its decomposition by sulphuric acid will give rise to the formation of a soda alum.

The manner of carrying the invention into effect is as follows:—In order to make a potash alum, the best substance to operate upon is a potash felspar. This felspar is ground in a common edge-stone mill to the consistency of fine sand (a process which is much assisted by heating it to redness, and then plunging it in cold water); it is then mixed with its own weight of sulphate of potash, and placed in the upper part of the inclined bed of a rever-

beratory furnace, similar in construction to that known in the potteries as a frit-furnace, and which furnace has previously been brought to a full white heat. When, by the action of the heat, a glass has been produced, and is observed to flow down the inclined bed of the furnace, to such glass is to be added gradually, at the lower end of the furnace, as much carbonate of potash as was before used of sulphate of potash; and this process of placing the mixture of felspar and sulphate of potash at the upper part of the bed of the furnace, is to be repeated, adding, at the lower part of the bed, gradually and proportionately, as the glass flows down from the upper part, the carbonate of potash, as before mentioned: this is continued until the sack of the furnace is filled with the glass, which is then fit for the next process.

The preparation of the glass may also be effected in a reverberatory furnace with a flat bed, and the facility of removing it from such a furnace is an advantage. In this case no carbonate must be added to the mixture until the sulphate of potash is observed to be completely decomposed.

On boiling the glass in water, the same quantity of potash as was added to the felspar, and two thirds of silica, contained in the felspar, are dissolved, while the remaining one-third of the silica, and the alumina, and an equal quantity of potash to that which the felspar originally contained, are left in the form of a light porous substance, similar in chemical composition to the mineral commonly called *alæolite*. This porous substance is carefully separated from the said solution, and washed with water until freed from the silicate of potash; it is then placed in an open leaden cistern or boiler, and boiled with dilute sulphuric acid of the specific gravity 1.2. This acid will contain about the quantity of water required for the solution and crystallization of the alum produced by the decomposition of the *alæolite*: the quantity of the dilute sulphuric acid must be such as will contain about 160 lbs. of dry sulphuric acid for every 285 lbs. of felspar rock (if that rock be used), and in like proportion to the silica and alumina contained in the substance, if any other substance be used. As it is important that the alum solution, thus obtained, should not contain an excess of acid, the patentee

recommends that only four-fifths of the proposed quantity of dilute sulphuric acid should be used in the first operation, which will leave a portion of the alæolite undecomposed; but, by acting upon this undecomposed portion, after the solution has been drawn off, with a full quantity of dilute acid to be used in the next operation, it will be completely decomposed, and the alum thus formed becomes part of the next batch: in this way a neutral solution of alum is obtained at each process. The boiling solution, after the sediment subsides, is drawn into coolers, such as are commonly used for the crystallisation of alum: about four-fifths of the alum held in solution, will form into crystals. The mother liquor is then drawn off, leaving the alum, which is now ready to undergo the usual process of washing and roaching. The mother liquor, from the coolers, is boiled in any convenient boiler to dryness, in order to render the silica it contains insoluble; this residuum is boiled, either in water, or in the mother liquor, from the roaching tubs, so as to dissolve the alum it contains, and the process of crystallization is repeated.

Had the above process been performed with the salts of soda, instead of potash, a soda alum would have been formed. For this purpose, the soda felspar, or albite, should be selected. The potash or soda (as the case may be) contained in the liquor drawn, as aforesaid, from the alæolite or nepheline (which is formed when soda is used) may be recovered by either of the following processes:—The strong solutions, which are obtained about the specific gravity 1.2, are placed in any convenient vessel, in which a stream of carbonic acid gas, obtained by any convenient method, may be driven through them; the carbonic acid becomes absorbed, and the solution assumes the form of a gelatinous mass: this mass consists of carbonate of potash or soda, and hydrate of silica. On drying this mass in a furnace, which must never be allowed to rise to a red heat, even in the dark, the silica loses its water, and becomes insoluble; the potash or soda may then be separated from it, in the form of a sesquicarbonate of potash or soda, by solution, and evaporation to dryness.

The other process, which, under most circumstances, will be found more economical and convenient, is to allow the

boiling solution of silicate of potash or soda to filter through a bed of caustic lime, when it will be found that the lime has combined with the silica, and caustic potash or soda-ley obtained :—This process may be conveniently conducted in an apparatus similar to that used by soap-makers for the preparation of their caustic leys. The potash or soda may then be readily obtained, as caustic potash or soda, or as a carbonate, by the ordinary processes. The weak solutions of silicate of potash or soda are used to decompose another portion of the glassy substance.

The patentee claims the improvements aforesaid ; and the production of substances similar to *alæolite* and *nepheline* artificially, by the decomposition, by water, of the glassy substances produced by the fusing of *felspar*, or other mineral substances containing silica and alumina, with salts of potash and soda ; and the use and application of such artificial *alæolite* and *nepheline*, in the production and manufacture of alum, as aforesaid ; he also claims the process, as above described, for separating the alkalies from silica, by means of caustic lime.—[*Inrolled in the Inrolment Office, April, 1843.*]

To WILLIAM EDWARD NEWTON, of the Office for Patents, 66, Chancery-lane, in the county of Middlesex, civil engineer, for an invention of improvements in the preparation of caoutchouc or India-rubber, and in manufacturing various fabrics of which caoutchouc forms a component part, —being a communication.—[Seald 30th January, 1844.]

THIS invention, communicated to the patentee by a foreigner residing abroad, consists chiefly in combining with caoutchouc, or India-rubber, certain portions of sulphur and white-lead ; and in submitting the compound thus formed to the action of heat, at a regulated temperature ; by which combination and exposure to heat it will be so far altered in its qualities, as not to become softened by the action of the solar rays, or of artificial heat, at a temperature below that to which it was submitted in its preparation, say, to a heat of 270° of Fahrenheit's scale ; nor will it be injuriously

affected by exposure to cold; it will also resist the action of the expressed oils, and likewise of spirits of turpentine, or of the other essential oils, at common temperatures, which oils are its usual solvents.

In combining the sulphur and white-lead with the India-rubber, these materials may be employed in varying proportions, but that which has been found to answer best, and to which it is advisable to approximate in forming the compound, is the following:—Take twenty-five parts of India-rubber, five parts of sulphur, and seven parts of white-lead. The India-rubber is to be dissolved in spirits of turpentine, or other essential oil; and the white-lead and sulphur are ground in spirits of turpentine, in the ordinary way of grinding paint. These three articles, thus prepared, may, when it is intended to form a sheet by itself, be evenly spread upon any smooth surface, or upon glazed cloth, from which it may be readily separated; but, for this purpose, the cloth made according to the present specification is preferred, as the compound spread upon this article separates therefrom more cleanly than from any other. Instead of dissolving the India-rubber in the manner above set forth, the sulphur and white-lead, prepared by grinding, as above directed, may be incorporated with the substance of the India-rubber by the aid of heated cylinders or calender rollers, by which it may be brought into sheets of any required thickness; or it may be applied so as to adhere to the surface of the cloth, or of leather of various kinds. This mode of producing and of applying the sheet caoutchouc by means of rollers, is well known to manufacturers. To destroy the odour of the sulphur in fabrics thus prepared, the surface is washed with a solution of potash, or with vinegar, or a small portion of essential oil, or other solvent of sulphur.

When the India-rubber is spread upon the firmer kinds of cloth, or on leather, it is liable to be peeled therefrom by a moderate degree of force; the gum letting go the fibre by which the two are held together. The inventor has, therefore, devised another improvement in this manufacture, by which this tendency is, in a great measure, corrected; and by which also, the sheet gum, when not attached to cloth or

leather, is better adapted to a variety of purposes than when not prepared by this improved mode, which is as follows:— After laying a coat of the gum, compounded as above set forth, on any suitable fabric, a bat of cotton-wool, in the state in which it is delivered from the doffer of a carding-machine, is laid over the fabric, and this bat is covered with another coat of the gum; a process which may be repeated two or three times, according to the required thickness of the goods. A very thin and strong fabric may be thus produced, which may be used in lieu of paper, for the covering of boxes, books, or other articles.

When this compound of India-rubber, sulphur, and white-lead, whether to be used alone in the state of sheets, or applied to the surface of any other fabric, has been fully dried, either in a heated room, or by exposure to the sun and air, the goods are to be subjected to the action of a high degree of temperature, which will admit of considerable variation, say, from 212° to 350° Fahr., but, for the best effect, approaching as nearly as may be to 270°. This heating may be effected by running the fabrics over a heated cylinder; but the inventor prefers exposing them to an atmosphere of the proper temperature, which may be best done by the aid of an oven, properly constructed, with openings through which the sheets or web may be passed by means of suitable rollers. When this process is performed upon a fabric consisting of the above-named compound, it must be allowed to remain upon the cloth on which it is made, in order to sustain it, as it is so far softened during the operation as not to be capable of supporting its own weight without such aid. If the exposure be to a temperature exceeding 270°, it must continue but a very brief period.

One of the improved manufactures or fabrics which forms part of this invention, consists of the India-rubber, prepared or compounded in the manner above described, and which is denominated “corrugated India-rubber goods.” These goods are formed by cutting sheet India-rubber into narrow strips or threads, say, of one-eighth or one-sixteenth of an inch, more or less, in width, and usually of about the thickness of a card. These strips are then stretched

upon a suitable board or table, in such a manner that they may pass backwards and forwards, parallel to each other, say, at the distance apart of one-fourth of an inch, more or less. The table or board is provided with pins or notches at each end; and around these pins, or through the notches, the threads are to be stretched, as they are passed backwards and forwards; the stretching of these strips may amount to twice, more or less, of their quiescent length. Whilst so stretched, two laminæ of cloth, or of other suitable material, of the requisite width and length, which are covered on one side with moist India-rubber cement, are to be placed one on either side of the stretched threads, the cemented sides being towards the said threads; these laminæ are to be brought into contact with each other, between the threads, which may be readily done by passing a smooth piece of metal, ivory, or other article, along the side of each of the threads.

Having stated the manner in which the corrugated or "shurred" India-rubber goods are made by hand, the inventor proceeds to describe a machine by which the process of manufacturing the said goods is greatly facilitated.

In Plate XII., fig. 1, is a longitudinal vertical section, and fig. 2, a top view, of a part of the machine; the stretching-frame *A, A*, which may be of great length, say 80 or 90 feet, being represented as cut off, and shewing only its two ends and a part of its middle portion. *B, B¹*, are two calender rollers, usually made of metal, between which the two laminæ of cloth, coated with India-rubber cement, and the stretched narrow strips of India-rubber, are to pass. These rollers, and others to be described, may be supported on a separate frame *c, c*, placed at one end of the stretching-frame *A, A*. At fig. 1, the frame *c, c*, and its appendages, are shewn in vertical section from front to back, through the middle. *D, D*, are two rollers, around which the cloth is to be wound, and carried thence to the two rollers *B, B¹*, between which it passes, embracing the stretched strips *a, a, a*, of India-rubber between them. *b, b*, represents the cloth in its passage from the rollers *D, D*, over those marked *B, B¹*. Around the roller *B¹*, and around a tightening roller *E*, passes an endless apron

c, c, c: this endless apron consists of gum-elastic cloth, or woollen, or other yielding material; its use being to cause the two laminæ of cloth, which have been coated with India-rubber cement, to be brought into contact between the stretched threads of India-rubber. *F*, is a part of a tightening frame, borne out by screws *G*, for tightening the endless apron *c, c*. *H, H*, are the screws for regulating the distance apart of the calender rollers. *I, I*, is a sliding-frame, which rests upon the longitudinal pieces, or cheeks, of the stretching-frame *A*, along which it may pass from end to end, being kept from lateral motion by suitable rebates or guides. To a cross piece *J, J*, of this frame, one end of each of the strips *a, a, a*, is attached in such a manner, as that the said strips shall stand parallel to, and equidistant from, each other. From this sliding-frame, they are carried over a grooved roller *K*, which preserves their parallelism. To stretch the strips *a, a*, straps *L, L*, are attached to the sliding-frame *I*, and pass over rollers *M, M*, at the near end of the machine, and down around the ends of the shaft *N*, upon which they are wound. By turning the shaft *N*, the narrow strips of India-rubber *a, a*, may be stretched to any required extent, and when the shurred, plaited, or crimped goods are being formed, the frame *I, I*, is allowed to advance towards the calender rollers with the same speed at which the peripheries of those rollers move, and carry the cloth from the rollers *D, D*. The corrugated material, as it is formed, may be allowed to descend after leaving the calender rollers, as shewn at *O*.

Instead of the foregoing arrangement for the cross-piece *J, J*, of the sliding-frame, a grooved roller may be substituted, and the ends of each of the strips *a, a*, being joined together (thus forming an endless band), may be passed round the roller *J, J*, and round that marked *K*, and under the calender roller *B*. The corrugated cloth, as it passes from the calender rollers, instead of descending, as at *O*, is in this case conducted round under the calender roller *B*, to the roller *J, J*. The distance between the roller *J, J*, and the calender rollers, must, under this arrangement, be equal to half the length of the corrugated goods, in the stretched state. The manufac-

tured article is, when thus made, to be removed from the machine, by cutting it across.

Under this last arrangement, the frame *I, I*, does not approach the calender rollers during the process; the rollers *J, J*, merely revolving, after the strips upon it have received the proper tension by the action of the straps *L, L*. Fig. 3, shews a pall on the shaft *N*, for preserving the tension of the threads *a, a*.

The patentee does not restrict himself to the use of any particular material, to constitute the laminæ by which the elastic threads are to be covered, as one side, for example, may consist of thin leather, and the other of cotton or other cloth. In the manufacturing of braces, silk ribbon may be used for one of the laminæ, and cotton cloth for the other; but, in general, a material of much greater width than ribbon will be used, and the article, when dry, cut into strips of such width, or into such other forms, as may be required.

When the material, thus formed, is removed from the board or machine on which it is made, it will, by the contraction of the stretched threads of India-rubber, become corrugated, so as to form distinct plaits between them; and although the same amount of contraction takes place upon the threads themselves, this part will be comparatively smooth, and the whole will present a corded appearance, which is in itself neat; and the fabric will possess a degree of elasticity, limited only by the cotton, silk, or other non-elastic material, which constitutes one or both of the laminæ.

The patentee claims, Firstly,—combining India-rubber with sulphur and white-lead, so as to form a triple compound; such combination being made either in the proportions herein named, or in any other, within such limits as are substantially the same, and will produce a like result. And, although the best results have been obtained from using the carbonate of lead, some other salts of lead, or the oxides of lead, may be substituted, which will produce a good result; the substitution, therefore, of such salts or oxides, in the place of white-lead, so as to form a triple compound, is included in this claim. Secondly,—the formation of a fabric of India-rubber by interposing layers of

cotton batting between those of gum, in the manner, and for the purpose above described. Thirdly,—in combination with the foregoing, the process of exposing the India-rubber fabric to the action of a high degree of heat, such as herein specified; by means of which, this improved compound is effectually changed in its properties, so as to protect it from decomposition or deterioration by the action of those agents which have heretofore been found to produce that effect upon India-rubber goods. Fourthly,—he claims, as a new manufacture, what is herein denominated corrugated or “shurred” India-rubber goods; that is to say, the forming of such goods by the stretching of strips or threads of India-rubber to such an extent as may be desired, and covering the said strips or threads, on opposite sides, with laminæ of cloth, leather, or any other suitable material; which laminæ are to be united to each other, and to the threads or strips, by means of India-rubber cement; the same being effected so as to produce a manufactured article substantially such as is herein set forth and made known. And, lastly, with respect to the above-described machine, he claims, combining with the calender rollers an elastic endless apron, such as is represented at *c, c*; and a stretching-frame, with its appurtenances, such as is represented at *1, 1*, for the purpose of giving and preserving to the strips or threads their proper tension, and allowing them to pass between the laminæ of coated cloth or other material, so as to produce corrugated or “shurred” goods, by an operation of the respective parts, substantially as herein set forth.—[Inrolled in the Rolls Chapel Office, July, 1844.]

Specification drawn by Messrs. Newton and Son.

To JAMES ROOSE, of West Bromwich, in the county of Stafford, Gent., for his invention of an improvement or improvements in the mode or method of manufacturing welded iron tubes.—[Sealed 9th May, 1843.]

THIS invention relates to improvements in welding the joints or seams of wrought-iron tubes, when made by external

pressure, by passing the iron, in a state fit for welding, between dies or through holes.

The improvement consists in employing internal support, in such a manner that the mandril (which gives the internal support) is fixed or stationary, during the operation of welding the tube; an "internal slit sliding tube," and a fixed outer or outward tube, or pulleys and guides, being placed on the outside of the stem of the mandril, for the purpose of stiffening it, and for giving the internal support; by which means the requisite pressure is obtained. When the tube has passed the bulb, and is on the stem of the mandril, and the weld is completed, the mandril used for giving internal support, owing to its being of smaller diameter, when compared with the internal diameter of the finished tube, may readily be withdrawn.

The manner in which this invention may be most readily carried into effect, is described as follows:—Firstly, I take a strip of iron, of the required length, breadth, and thickness, depending on the diameter and length of tube required, and proceed to turn, draw, or convert it into a skelp, or form of tube. If for a lap-joint tube, I proceed to bend the strip of iron into a cylindrical shape, by bringing the edges together, or nearly so; the one edge lapping a little over the other edge, as is commonly practised in making welded lap-joint iron tubes. When the tubes are thus far prepared, they are placed in a furnace, so as to bring the two edges to a good welding heat, and when in this state, the tubes, having a mandril within each of them, are to be drawn through the dies. At the mouth of the furnace I place the end of a draw-bench, and upon this bench I place two stops;—against these stops a die or dies, or a pair of groove-rolls of the required size for the tube about to be welded. A mandril, made in the form of that shewn in Plate XII., fig. 1, is placed upon the draw-bench, as is shewn, with pulleys and guides placed upon the outside of the stem of the mandril. These pulleys have grooves in them, of the required diameter, and revolve by the passing of the tube, and are for the purpose of stiffening the stem of the mandril, so as to keep it from bending while the welding pressure is upon it. One end of

the mandril is to be made secure at the back end of the draw-bench, and the other end is to be passed through the die or dies, or groove of the rolls; a ferrule or ring of iron or steel is to be placed in the end of the tube which first passes over the mandril, and is capable of sliding over the stem thereof (see fig. 2). When these instruments are so prepared, and the skelp or tube is at a welding heat, the mandril is to be forced through the die or dies, and sufficiently inserted into the skelp or tube to allow of the end (which was previously made smaller,) being passed through the die or dies, or groove of the rolls. The iron or steel ring, or ferrule is now to be pushed inside the end of the skelp; the pliers shewn at fig. 3, should then take hold of that part of the skelp or tube in which the ferrule or ring is inserted; and the chain of the draw-bench, being attached to the pliers, should be immediately set in motion, when the hot skelp or tube will be drawn along and over the mandril, and through the die or dies, or through the groove in the rolls. The compression on the outer surface of the edges or join of the hot skelp or tube, and the resistance opposed by this way of using or stiffening the stem of the mandril within, will effect the welding of the joint or seam more firmly, and allow more or greater external pressure on the outer surface of the skelp or tube; this will cause a greater reduction of the substance or thickness of the iron, and lengthen the skelp or tube much more than is now done in the welding of wrought-iron tubes, which will be found most advantageous in such production.

The iron preferred by the patentee for welding into tubes upon the principle of lap-joints, is from nine to fifteen wire gauge; depending upon the reduction of each heat and strength of tube wanted; but he does not confine himself to any particular thickness or form of iron. The pliers (fig. 3,) are the same as those now used in the welding of iron tubes, when drawn, with this difference, that at the top of the perpendicular pillars they turn in, or are bent in a direction pointing to each other, and form at their end part of a circle, so as to go between the pulleys, and grasp the pipe or tube. The mandril has a bulb at one end, which first enters the tube, and should be a little taper. The back

end of the bulb should be the size required for the diameter of the tube, when the final welding pressure would be from the die or dies, or from the groove in the rolls, which would leave the inside surface smooth. The patentee does not confine himself to any particular form of mandril, but prefers the one shewn at fig. 1; the die or dies are in the form of hand-tongs, having a bell or enlarged mouth; these tongs are very similar to those now used in the welding of wrought-iron tubes. The patentee does not confine himself to the form or shape of the die or dies, but prefers the pressing dies in the form of tongs, on account of the cheapness of their construction, and the facility they offer for being cleansed, by dipping them in water after each using, when the scale, if any adhere, may be readily removed: such construction of dies also allows the workman to change them from one size to another more readily, at the same time. In making a butt-joint, the two edges of the skelp should stand up a little, or in preparing the skelp, the edges standing up should touch each other, (that part being partly of an oval form or shape) so that when the welding pressure is upon it, such would have the effect of pressing the joint together; the greater part of the pressure being on the joint or seam. The tube is again reheated, and drawn through the die or dies, as may be required; the same end first entering the die or dies as before, which may be kept a little larger than the bulb of the mandril, on account of its allowing the mandril to be quickly inserted, and the pliers to grasp it without chilling the heat. The tube, after being passed through the die or dies sufficiently often, so as to finish and complete the welding, and making it equal in its thickness, is then placed on a shortening-plate, the ends cut off, and then finished. If the grooved rolls are used in the drawing of the tubes, when in the process of welding they should revolve by the draught of the tube passing, and not by machinery.

Another method of producing welded iron tubes according to this invention, is as follows:—A strip of iron is first converted into a skelp or form of tube, by any of the known methods, and placed in the furnace, as before. Near the

mouth of the furnace is a pair of rolls, capable of being driven by machinery, having grooves of a required diameter and form. Between, or in each of the grooves of the rolls, is the bulb of a mandril, at the back end of which is a stop (see fig. 4.), inserted in a slot in the mandril. This stop is attached, and fastened in, or to, a trough, by which the mandril is suspended. On the outside of the mandril is a tube, having a slit nearly the whole of its length; the tube is much longer than the mandril, and the slit is for the purpose of allowing the tube to slide over the stop at the back end of the mandril. On the outside thereof, a fixed tube is placed, which is large enough in its diameter to admit the hot tube to pass without being an obstruction; and when the tube has reached a good welding heat, it is forced under the grasp of the rolls, and the draught or friction of the rolls passes the tube through, immediately the slit sliding tube is drawn off, by machinery, or any other means that may be preferred. When the hot tube is sliding on the mandril, the cold slit tube is sliding off. This sliding tube passes inside the fixed tube, and is for the purpose of preventing the end or edge of the hot tube offering resistance against the fixed tube. These two tubes, namely, the slit sliding tube, and the fixed outer tube, are for the purpose of giving support, and preventing the stem of the mandril from bending, so that it may retain its position while the welding pressure is upon it. After the hot tube has passed the bulb of the mandril, and the sliding tube has passed off, the back end of the stem of the mandril is heaved up and knocked with a hammer; the bulb is then taken hold of, and the hot tube drawn off. It is then placed in the furnace, and again passed under the pressure of the rolls, as often as found requisite. The patentee does not confine himself to the using of these tubes, as pulleys may be applied in this case.

Fig. 5, represents the draw-bench in elevation. *a*, is the mandril. *b*, *b*, are rollers mounted in the framing *c*, *c*, for supporting the mandril. *d*, is the stop at the back end of the mandril; and *e*, the stop for the tongs or dies; *f*, represents the pliers, shewn detached at fig. 3.

In conclusion, the patentee states, that, "What I claim as

this part of my invention, is giving support to the stem of the mandril, in whatever way it may be applied, for the purpose of giving support or stiffening. I likewise claim the construction of the mandril with a slit in it, in which the stop is fixed in; and I claim the construction of the pliers used for grasping the tube between the pulleys, &c. And, after having so far described the nature of my invention, I would wish it to be understood, that I do not confine myself to the various details shewn and described, provided the particular mode of applying internal support, when support is given to the stem of the mandril, combined with the welding of wrought-iron tubes, by external pressure, be retained, whereby a mandril with pulley, or pulleys and guides, or a slit sliding tube, and a fixed outer tube, is placed on the outside of the stem of the mandril, and is thereby caused to give any internal support that may be wanted to the seam, or joint of the tube, when being welded by external pressure; and whereby the mandril is stationary, while in the operation of the tube being welded, very similar to that called, and well known by tube masters, as the suspended mandril, and be released after the weld is obtained; owing to the stem of the mandril being smaller in its diameter than the internal diameter of the tube, and the support of the mandril being no obstruction, as above described."—[*Inrolled in the Inrolment Office, November, 1843.*]

To WILTON GEORGE TURNER, of Gateshead, in the county of Durham, Doctor in Philosophy, for the manufacturing of salts of ammonia, and compounds of cyanogen, from a substance never before applied to that purpose.—[Sealed 11th March, 1844.]

THIS invention consists in manufacturing salts of ammonia (the muriate and sulphate of ammonia), and compounds of cyanogen (the prussiates of potash and soda, and Prussian blue), from the substance called guano.

The patentee first describes his method of producing both salts of ammonia and compounds of cyanogen from guano, by one process: the salt of ammonia, in this case, being the

muriate, or sal-ammoniac, and the compound of cyanogen being the ferrocyanide of iron, or Prussian blue.

The guano is subjected to destructive distillation, in close vessels (similar to gas retorts), at a low red heat, during the greater part of the operation; but this temperature is increased towards the end. The products of distillation are conducted into an arrangement of vessels, constituting what is termed a "Woulfe's apparatus," by means of which the gases, evolved during the process, may be made to pass two or three times through water, before escaping into the air. This apparatus may consist of large wrought-iron vessels, connected by cast-iron pipes, and having each a pipe passing through the top, and trapped by the water in the vessel, to serve as a safety-valve: a series of three vessels will be sufficient.

The products of the destructive distillation consist principally of hydrocyanic acid, carbonate of ammonia, and carburated hydrogen, which being conducted into the Woulfe's apparatus, the two first-mentioned are rapidly absorbed by the water, forming a strong solution of hydrocyanate and carbonate of ammonia. The ammoniacal solution should be removed from the first receiver of the apparatus, and replaced by water, after the distillation is complete, if much ammonia has passed into the second receiver, as this is a criterion that the water in the first is saturated; the second receiver must in like manner be emptied, and refilled with water, when the ammonia begins to pass into the third. After the ammoniacal solution has been removed from the apparatus, a solution of protomuriate of iron is added to it, in such quantities as will yield sufficient iron to convert the hydrocyanic into hydroferrocyanic acid, and to convert the latter into Prussian blue, which is formed on the addition of muriatic acid in sufficient quantity to neutralize the free ammonia; the precipitate, thus formed, is now allowed to subside, and is carefully separated from the solution; and, by being boiled with a solution of potash or soda, will yield the ferrocyanate of the alkali, which is obtained by crystallizing, as usual. The solution (after the removal of the precipitate) should be freed from any excess of iron it may contain, by the careful addi-

tion of a fresh portion of the ammoniacal liquor, by which the oxide of iron will be precipitated, and a neutral solution of ammonia obtained. When the precipitated oxide and cyanide of iron have subsided, the solution of muriate of ammonia is drawn off by a syphon, and the sal-ammoniac obtained from it by the usual processes: the oxide of iron is added to the ammoniacal solution next operated upon.

If sulphate of iron and sulphuric acid had been used, sulphate of ammonia would be the ammoniacal salt produced; but the chemical changes and operations would be similar to the above.

The patentee next describes his mode of adapting the usual process of making compounds of cyanogen, when horn is employed, to the manufacture of compounds of cyanogen from guano.

If, without any preparation of the potash or guano, the latter be used in the same manner as dried blood, or any of the matters generally employed, no prussiate will be obtained, until enough guano has been burnt away for the residuum to form the excess of carbon required for the purpose; and, at the same time, the ammonia evolved is stifling. But, by mixing carbonaceous matters with the guano, and charging the potash with free carbon, the whole of the nitrogen may be converted into cyanogen, instead of escaping as ammonia. The carbonaceous matter preferred for mixing with the guano is coal tar or pitch, and a good clean coal: the employment of tar is very advantageous, for, besides furnishing carbon, it binds together the dry powder of the guano; and thus not only prevents the dry powder from being thrown out of the pot by the rapid combustion, but, from its tenacious qualities, holds in the ammonia until decomposed by the fused potash. Various mixtures of the materials may be made; but the following formula has been found advantageous:—Bring 42 lbs. of good Montreal ashes to a perfect fusion, by a strong red heat: add a mixture of 7 lbs. of coal and 3½ lbs. of hæmatite, finely powdered, in small portions at a time; and, after it is well worked in, allow the pot to “gather its heat again;” then work in a mixture of 7 lbs. of perfectly dry guano, 7 lbs. of coal, and 3½ lbs. of tar; and finish by

working in 21 lbs. of guano, with 10 or 11 lbs. of tar. The ball of metal or compound of cyanogen, produced by this operation, is as rich as one made from 42 lbs. of potash and 84 lbs. of horn, and should now be treated in the usual manner for obtaining the prussiate of potash therefrom.

If soda had been used, instead of potash, the compound of cyanogen obtained would be prussiate of soda.

The patentee claims, Firstly,—the use of guano for the production of salts of ammonia, and compounds of cyanogen, by one process of destructive distillation and treatment, as described. Secondly,—the use of guano, instead of other animal matters, heretofore commonly used in the manufacture of compounds of cyanogen; and the adaptation of guano to this process, by the admixture therewith and use of tar, coal, or other carbonaceous matter, as described.—[*Inrolled in the Inrolment Office, September, 1844.*]

To HENRY DU BOCHET, of 46, South Mall, in the city of Cork, Ireland, piano-forte tuner, for a new method of making piano-fortes.—[Sealed 11th February, 1843.]

THIS invention relates to the class of instruments termed “grand square piano-fortes;” and is shewn in Plate XII., at fig. 1, which represents the “action” of one of these piano-fortes. The improvements consist, firstly, in the application of a small block of wood *a*, (bevilled on one side,) to the upper end of the clapper *b*, of the hopper; from the under side of which block *a*, a wire *c*, with a screw formed upon it, projects, and is screwed into the head of the clapper; so that by turning the wire, the height of the block may be regulated with great exactness. Secondly, in fixing a piece of felted cloth or other elastic substance *d*, to the front of the check *e*: which cloth rises about a quarter of an inch above the head thereof, to check the hammer at a point between the said check and the string, when the key is struck with less force than is necessary to bring the hammer down to the check. The object of these improvements is to obtain a repeating touch which can be made available at any required depression of the key.

In cases where it is not considered requisite to use a regulating screw *c*, as above described, for the purpose of raising or lowering a block *a*, on the top of the clapper of the hopper, the repeating touch is obtained by altering the hopper in the manner shewn at fig. 2, combined with the application of the felted cloth to the check. A hole, one-eighth of an inch in diameter, is bored through the upper end of the clapper *b*, at about three-eighths of an inch from the top; through this hole is passed a piece of wire *f*, of a thickness equal to one-fourth the diameter of the hole, and three-fourths of an inch long, with a screw formed upon it from one end to the other; one end of the wire is screwed into a small block of wood *g*, (see the detached view, fig. 3,) bevelled in a similar manner to the block *a*, and on the other end of the wire is a wooden nut or button *h*, by means of which the block *g*, may be fixed at any position within the range of the hole.

The patentee says, that for instruments of an inferior description, he glues the block *g*, to the clapper.

He claims as his invention "the new method of making piano-fortes, as above described, being a new combination of mechanical means, by which the desired effect of the repeating touch is better than heretofore obtained in grand square piano-fortes."—[*Inrolled in the Inrolment Office, August, 1843.*]

To JOHN WOOD, of Parkfield, Birkenhead, in the county of Chester, merchant, for improvements in machinery or apparatus for affording additional or artificial buoyancy to sea-going and other vessels, or for lessening their draught of water; which improvements are also applicable to raising vessels or other heavy bodies, and for securing or supporting the same.—[Scaled 14th August, 1843.]

THESE improvements consist in the novel application of well-known principles and materials, and in the peculiar combination and arrangement of apparatus adapted to the above purposes. The improvements apply, firstly,—to sea-

going or other vessels, being designed to afford additional or artificial buoyancy, or to lessen their draught of water, and may be employed either externally or internally; secondly,—the improvements apply to raising vessels, or other heavy bodies, and consist in a similar application of apparatus, suitably adapted for such purposes; and, thirdly,—the improvements apply to sustaining or securing weight, and consist, also, in a further application and modification of similar apparatus, suitably arranged for the purpose. The main feature of novelty in each adaptation of these improvements, is the employment and use of common or condensed air, contained in suitable apparatus, and in the convenient application of the same to the circumstances required.

In Plate XI., the apparatus for affording additional or artificial buoyancy to sea-going and other vessels, or for lessening their draught of water, is exhibited. This apparatus may be used both externally and internally. Fig. 1, is a vessel, capable of retaining condensed air, made of any flexible material, as India-rubber or caoutchouc cloth, oiled silk or cloth. Fig. 2, represents a case for the former, made of a strong fabric of cloth, as canvass, or, if necessary, of metal or timber. The air-vessel is preferred to be made of India-rubber cloth, from its perfection in retaining condensed air, and its elasticity and strength. For the case, oiled canvas, from its combining great strength with flexibility, is preferable for general purposes. For the tackle, cordage is generally preferable to chain, not being liable to rust, nor to injure the ship's sides, and being more suitable to the other materials when of cloth. The shape of the air-vessel may be varied,—globular, cylindrical, triangular, &c., but the spherical form generally answers best, from its greater strength, capacity, and economy of material. Fig. 1, represents a globular air-vessel, of India-rubber cloth, with encircling bands of loops. *a, a*, are the apertures, in which are inserted brass union joints, for connecting the air-vessel with the hose through which the air is forced into it. Fig. 2, represents a case of canvas to enclose the air-vessel, having holes corresponding with the loops in fig. 1, and serving also for the freer egress of water; at *b, b*, the case divides into two parts,

which are united by lacing, or what sail-makers denominate a "latchet." At *c, c*, the case also opens, on one side, by unlacing; these openings are for the purpose of receiving the air-vessel; *d, d*, are apertures corresponding with those in fig. 1, for the union joints to pass through. Fig. 3, represents the holding tackle, of ropes, in size and number suitable to the weight they are intended to bear, and crossing each other, so as to act as a sort of second case for the air-vessel when inflated; the rope-work itself forming a true sphere, of a sort of net-work, the cross-ropes being tied or seized at the points where they meet. From *e*, to *f*, other ropes are attached; each of the latter taking hold of one of the former, so that the strain of the weight, when lifted, may be distributed as much as possible over the whole surface of the globular figure; the latter ropes are to be united to similar ropes on a second air-vessel, as represented in this figure, and the junction of these ropes forms a sort of cradle for the ship's bottom and sides to rest upon, between the two air-vessels; the air-vessel case, and rope-work, are then united together by the loops or latches; *g, g*, are the ropes for making fast on deck, to timber heads, or any part strong enough to hold. For the greater protection of the air-vessel, the canvas case is of rather smaller capacity than the former; and the casing of rope, again, rather smaller than the canvas one; by this arrangement, the air-vessel cannot burst by inflation, or external pressure, until the outer canvas does so, neither can the canvas burst, except through the apertures of the ropes (which may be made close enough to prevent it) until the latter give way, whilst each rope is measured to bear its own portion of the weight sustained. *h, h*, is the place of union of the rope-work, which may be united by means of "cliphooks and thimbles;" the extremities of each part may be removed, if necessary, to shorten the band of rope-work between the two air-vessels; and the inner set of hooks may be united to the corresponding thimbles, and the number of these divisions of the band may be increased if necessary. *i, i*, is the hose, made of the same material as the air-vessel, with a case of canvas, and a spiral rope running round the canvas, to keep it from injury, and

also to prevent the air-tube or hose inside, from being so bent at any part, as to prevent the passage of air through it ; for this latter object also, a piece of cord runs through the whole length inside the air-tube, fastened inside at each end. The tube, or hose, may be attached to the air-vessel, at either of the union-joints, or both apertures may be united to tubes ; the other end of the tube, or tubes, communicating with the nozzle of the air-pump or bellows on deck, by means of a union tube, of any convenient form ; or each air-vessel, by its hose, may communicate in succession with the bellows or air-pump. The second aperture, for the insertion of hose in the air-vessel, serves for the purpose of more rapidly inflating or exhausting the latter when necessary ; or it may serve for a safety-valve to indicate the degree of pressure of the air, upon the interior of the air-vessel.

The patentee shews a modification of the air-vessel, of India-rubber cloth, with the canvas case permanently united to it, by means of the caoutchouc process, so as to form of both one substance. Bands, with loops, are united by the caoutchouc process to the outside of the canvas ; the loops serving to confine the holding ropes, passing through them in their proper places. These ropes, when once fitted and fastened, may remain so ; thus making only one, instead of three parts ; and the globular rope-work, in this instance also, being of smaller capacity than the air-vessel, bears the chief strain in the first instance. Instead of ropes encircling the air-vessel, strong canvas bands may be substituted ; the latter being united to the outside of the canvas ; and at the points where they meet, at the lower part of the sphere, their ends may be left pendent, and so strengthened as to allow of the holding ropes being attached to them ; and this arrangement would reduce the apparatus to a smaller bulk.

Another arrangement of the holding tackle, or ropes, adopted by the patentee, is encircling the whole sphere with every rope, and arranging them so that they shall cross each other obliquely ; by which means, each set of ropes, converging at different points or poles, will allow of cables or chains being fastened to the air-vessel, at such points. The cables thus attached, passing under the ship's bottom and

sides, and the ends being made fast on deck, the strain or pull of each is distributed over the surface of the air-vessel.

Fig. 4, represents two cylindrical air-vessels, with the ropes or chains uniting them at *l, l, l*; these ropes pass under the ship's bottom, one air-vessel running along each of her sides; *g, g*, are the ropes for making fast on deck; and *i, i*, the hose for inflation. The encircling tackle may be arranged according to either of the preceding modes. The cylindrical shape has the advantage of being extended along three-fourths of the ship's length; thereby more equally distributing the pressure along the ship's side; but this advantage is counter-balanced by the increased expense, the spherical shape being the most capacious of any figure, and in that respect the cheapest, which is of importance, where so great a surface of material is required. Fig. 5, represents a side elevation of a ship, with three pairs of air-vessels, similar to those shewn at fig. 3. *a, a*, is the water line; *b, b*, are the air-vessels, each pair being united by the cradle of rope-work *c, c*; *d, d*, are the holding-ropes, attached to the deck; and *e, e*, are the hose-pipes, in connection with an air-pump, or bellows, on board the vessel; supposing the vessel to be drawing sixteen feet of water, when loaded, and the air-vessels each to be fourteen feet in diameter when inflated and immersed, each air-vessel will displace about forty tons weight of water, and the six together, 240 tons weight; and being firmly attached to the ship, by their upward pressure they lighten her weight by nearly so much, and her draught of water proportionably. Fig. 6, represents a portion of a ship, with one pair of spherical air-vessels, made according to the modification last described: supposing the ship to be drawing twenty-two feet of water, *a, a*, being the water-line; and suppose the diameter of each air-vessel to be twenty feet immersed and inflated, they will displace together also about 250 tons weight of water, lightening the ship's weight and her draught of water proportionably. *b, b*, are the ropes, extending from the corresponding air-vessel on the other side of the ship. To each air-vessel ropes are attached, which cross each other under the ship's bottom, and form for her a sort of cradle, which prevents the ship being strained by this mode of raising her as

effectually as in fig. 5 ; the vessel in this figure is necessarily shewn reversed. Fig. 7, represents a portion of a ship, with an air-vessel attached at the bow, corresponding with another attached at the stern. The air-vessels, in this instance, are united by cables, passing longitudinally from one to the other, under the bottom or bilges of the ship. The two ends of each cable are carried up on deck through the chain-ports *a, a*, and hauled tight by the windlass and capstan : slips of chain, at *b, c*, and *d*, are attached to the cables and to the air-vessels ; passing over rollers, if necessary. The air-vessel, on inflation, pressed upwards by the water, and swinging out from the vessel, pulls the slips of chain in the same direction, turning on the point at *b*, as on a sort of centre of action ; which motion also causes the air-vessel to escape contact with the rudder. In this way the burthen of the ship is thrown entirely upon the cables under her bottom.

To prevent the necessity of passing the holding tackle under the ship's bottom, ring-bolts or hooks may be inserted in the sides of the vessel, and to these the air-vessels may be attached, by means of iron rods run through thimbles in the holding tackle ; which rods, when hauled up the side of the ship, get under the rings or hooks in her sides, and being once hauled tight, the inflation of the air-vessel will keep them so. With regard to the most suitable and easy method of shipping the air-vessels in their proper places, this will depend upon the position of the air-vessels. The globular air-vessels may be applied in the following manner :—The ship being afloat at the time, each pair of air-vessels should be kept rolled up, (when not in use,) with all their tackle ready, something after the manner in which a mainsail is rolled up, for being carried to or from a ship ; they will then have somewhat of the appearance given in the sketch at fig. 8. *a, a*, are the two air-vessels rolled up ; *b*, the rope-work uniting them ; the part *b*, is dropped over the stern, and the collapsed vessels *a, a*, over the quarters ; the latter being held on by the ropes *d, d*, each of which has a noose, in which each air-vessel is held or lowered down, until secured. When the part *b*, is below the keel, the whole is hauled forward by the ropes *d, d*, on each side of the ship, to their

proper place; the ropes *e, e*, are then hauled up, but having been previously passed through thimbles, in the nooses *i, i*, they slacken, and pull up the nooses at the same time; and the ropes *c, c*, and *g, g*, being hauled horizontally, one a little forward, the other a little aft of the air-vessel, where they are made fast, the latter is completely opened out, the ropes *e, e*, being also first made fast on deck; the upper ends of the hose *f, f*, are screwed on to the bellows or air-pump on board the vessel. The second and third pairs of air-vessels are then put on the ship, in a similar manner, when inflation commences, and the ship is raised in the water.

These improvements for lessening the draught of water of vessels are also to be applied internally, and must be suitably arranged and modified to the adaptation of the interior of seagoing or other vessels, as circumstances shall require.

Firstly,—the air-vessels, with their furniture, already described, are adapted for vessels carrying little cargo, or having sufficient space in the ship for inflating them, varying only the holding tackle; so that the air-vessels may be secured down to ring-bolts, or other fastenings, into the frame of the ship, in number sufficient to divide the pull throughout the length of the ship, when the influent water, (from springing a leak) bears the air-vessels upwards.

Secondly,—air-vessels, of metal entirely; iron, copper, tin, &c.: the last, from its cheapness, is preferable. The shape of these must depend on the spaces they have to occupy in the ship. Like the former, when used internally, they are chiefly intended for ships having large unoccupied spaces, as vessels of war, channel and river steamers, &c. The globular figure of the air-vessels, for strength and economy, will here also answer best, and as the cubical contents of spheres increase in a greater ratio than their surfaces, the larger it can be made for the space allowed, the cheaper. The cylindrical figure shewn in fig. 9, is the next preferable shape, but the square, oblong, conical, or any other figure, is applicable to this purpose, the object being simply to occupy with an air-vessel every space in the ship, which, on her springing a leak, would otherwise be occupied with the same bulk of water. The air-vessels being first filled with condensed air;

and the aperture through which it is introduced hermetically sealed, are firmly secured down to the frame, of the ship as before mentioned, by chains or wire rope proportioned to their size.

Fig. 10, represents a longitudinal section of the after part of a river or channel steam-boat; *a*, is the cabin; *b*, the unoccupied space under the cabin; *c*, the space for ballast. The space *b*, instead of being left void, is to be filled with air-vessels *d, d*. If the steamer, by collision or other accident, now fills with water, the space which the water will occupy is curtailed by the air-vessels into such small compass, that its whole weight, added to the weight of the vessel and stores, will not augment her draught of water over a few inches. If the air-vessels be removed, the hold will be completely filled with water, the weight of which, added to the weight of the ship and her other contents, will cause her to sink. The air-vessels should, however, be placed as low in the ship as possible above the ballast. The necessity for this arrangement will be apparent, by supposing them placed in the space *a*, instead of in *b*; the space *b*, would then be entirely occupied with water, and although the air vessels in the cabin (whether of metal or cloth) would be sufficient to keep her afloat, yet she must sink nearly to the water's edge by the greater weight of water in the hold, and become in consequence more unmanageable. In the same manner the hold of a first-rate ship of war will give more effect to the air-vessel than the space on the orlop deck, and the latter for the same reason is preferable to the space on the first gun-deck. This description of air-vessels is also applicable, but at a comparatively great expense, to ships carrying cargo, by filling up therewith (in addition to flexible air-vessels for inflation in the cabin and fore-castle) the following and similar vacant or lost spaces in every vessel; namely,—the spaces about the ship's entrance and run, inside the interstices between the side timber or frame, between the beams and carlines of the upper and lower decks; the space reserved for "dennage" down the sides, the bilges, and the floor, being from six to nine cubic inches over nearly the whole of the ship's interior surface, under the berths, and all waste spaces in the cabins, state-rooms, fore-castle, &c.

Thirdly,—for the interior of vessels, in which the entire capacity of the hold is occupied with cargo, the following is a description of the most efficient apparatus: namely,—a lining or sack, equal in capacity to the hold, or made in two or more divisions, with mouths corresponding with the hatchways. The material of the sack is India-rubber cloth, or cloth well oiled, with a canvass or other strong covering or case, on both sides, loose, or forming together one substance with the former, and, by means of loops or ties on the canvas, united to another cover of strong and durable material, as matted cordage, with a soft surface next the canvas, and protecting the side of the canvas on the skin of the vessel, and the side exposed to the friction of the cargo. The side next the skin, deck, and beams of the vessel, is made fast thereto by ties, at suitable points, to keep the sack in its place; or it may be more perfectly secured from the friction of the cargo by a covering of strong boards, keyed together by a cross board; the latter, at convenient points, being secured by means of a screw, passing through it, and through the cloth, into the frame of the ship; the edge of the aperture in the cloth being carefully bound round the screw, to preserve its water-tight property from injury by the puncture. The lining may be taken out for airing, or drying, if necessary, after each voyage. The effect of this apparatus is obvious. The whole frame of the ship, with its exterior and interior planking, becomes a protection to the sack from external injuries, to which the ship herself is exposed; and so long as the sacks are uninjured, the vessel, becoming leaky, can only admit as much water into the hold as will be between the sack and the ceiling, or between the timbers of the vessel, which would not probably augment her draught of water more than an inch or two; the whole weight of the cargo pressing the sack close down to the ceiling.

The second head of these improvements, namely,—the apparatus for raising vessels, or other heavy bodies, consists (with the exception of a “jack,” described below) in the application and employment of the air cases already mentioned; the tackle only being varied, according to the position or nature of the body to be raised. In the case of a vessel

or heavy body that is sunk in deep water, holding tackle is attached to it in the usual manner; the tackling of the air vessel or vessels is then conveniently attached, and as the latter become inflated, the whole rises to the surface, or after being raised to the proper height beneath the surface, is floated into shallow water. If it be required only to raise the body a few feet, as on board ship from a lighter or boat, alongside, or from on board ship to the pier or quay, a metal-cased air-vessel, (represented at *a*, fig. 11,) suppose of one ton weight, or one with a case of wood having weights to that amount attached, is to be used; the air-vessel, by means of a chain or rope, secured to it, is lowered into the water, the other end of the chain passing over a crane or pulley *b*, to the body to be raised, as a hogshead of sugar; so long as the interior flexible air-vessel is inflated, it remains with its weighted case on the surface of the water; as the air is allowed to escape, the water rushes through the holes into the case, and it sinks with nearly the weight of one ton, which raises the hogshead at the other end of the chain, if of lesser weight; by reinflation, the descent of the air-vessel is checked at the proper point, or brought again to the surface. The flexible air-vessels are applicable also to raising heavy bodies on land, without the aid of water. For this purpose, such heavy bodies are to be laid on the cradle, bands, ropes, or chains, uniting two air-vessels; the air being first exhausted from them. The inflation causes them to rise to a height proportioned to their diameter, and the body, lying beneath, rises with them. By simply extending the surface of the air-vessels, and augmenting the degree of condensation of the interior air, any supposable weight may be thus lifted. Fig. 12, represents a sort of "jack" for raising weights. It consists of a strong cylindrical air-vessel *a, a*, of India-rubber cloth, or strong leather covered with India-rubber cloth, and moving in a strong iron frame *b, b*, by means of pins *c, c*, fastened to it at the top and bottom, and passing through regulating or steadying rings *d, d*, in the frame; the whole is provided with a strong iron pillar *e*, in the centre, on which the weight to be lifted is supported. In the figure the air-vessel is represented as in a collapsed state, or

exhausted, and its sides falling in; on inflation, it rises to the length of the pins, with the weight under which it has been placed; the air within being first condensed proportionably; the stop-cock *f*, is then turned, and the air-vessel remains inflated.

The third head of these improvements, namely,—the apparatus or machinery for securing and sustaining weights, consists of an iron platform, on which are secured air-vessels, of iron or other suitable material, filled with condensed air, and hermetically sealed, in number and capacity proportioned to the weight to be sustained; and adapted to form floating piers for permanent bridges over broad and deep rivers; and to sustain floating slips, lighthouses, or other erections. Fig. 13, represents an elevation of a floating pier, sustained by air-vessels of iron, well secured in a frame, with portions of a suspension bridge of the same material. The air-vessels are to be moored by anchors and chains; or, as represented in the plan, by the screw-pile moorings, which answer the purpose better. The air-vessels are in such number, and their available capacity is such, as to obviate danger from injury; and they are placed at a sufficient depth below low watermark to escape the agitation of waves, which is confined to the surface. As they are constantly immersed in the water, they are little affected by the rise and fall of the tide, and being ballasted by additional weight below, sufficient to counteract any leverage on the piles of the weight above water, they sustain or support the bridge with a sufficient degree of steadiness; the piers, from the principle of their construction, being at the same time uninjured by such vibrations as may occur from the action of the wind, or of heavy carriages crossing the bridge. The shape and number of the air-vessels may be varied according to circumstances. Fig. 14, represents a sectional plan view of the pier. *a, a, a*, are the screw-piles, which the patentee prefers to be of that description called "Mitchell's patent," fixed at the requisite depth in the bed of the river, and cross-braced in two heights, as shewn by the diagonal dotted lines; these piles are to be fitted with air-chamber guides and stops, to prevent such chambers rising too high. *b, b*, is the air-chamber frame, in three divi-

sions, the two upper for air-chambers, and the lower for ballast; *c, c*, are uprights, rising from the platform, above the air-chamber, and carrying the lower turn-plate and framing *d, d*, which is a horizontal frame, to receive a vertical spindle from the upper turn-plate; *e, e*, turn-plates, with rollers between them; *f, f*, pedestals for the chains, secured to the upper turn-plate, and cross-braced over the roadway; *g, g*, the carriage-way and foot-path; *h, h*, are the chains, passing over saddles in the pedestals to the roadway; *i, i*, the river wall or pier; *k*, the point at which another portion of the bridge may be locked. A circular rack may be applied to the lower turn-plate, and a multiplying power, worked by a winch or capstan, may be applied to it, for swinging the bridge, if desired. Fig. 15, represents a plan for an arrangement of six spherical air-chambers; and fig. 16, an end elevation of the same. Slips or jetties for landing, thrown out to any distance from the shore, as also lighthouses or other floating erections, are to be sustained and secured by similar means.

The patentee states, that he is aware of air-vessels, of different materials, having before been applied in various ways to shipping, and to other heavy bodies, immersed and afloat, but not of the peculiar construction, or for accomplishing the results specified above; as, for instance,—for the purpose of so controlling the draught of water of a ship of any size, so as to render her incapable of sinking, from any casualty, below a certain safe point; and at the same time investing those on board with the complete command of her position afloat and loaded; so that for convenience, safety, or repairs, her ordinary draught of water may, with facility, be lessened to any required degree, either from stem or stern, or only at the fore or after part, or on either side alternately—nor for the purpose of raising vessels and heavy bodies, either to the surface of the water, or to a given height on land, by apparatus of the construction above specified—nor lastly, for the purpose of sustaining and securing floating erections, and weights of any kind afloat, by the means described above.—
[*Inrolled in the Petty Bag Office, February, 1844.*]

ON THE LAWS RELATING TO LETTERS
PATENT FOR INVENTIONS.

No. XX.

THE PATENT LAWS OF BRAZIL.

THE granting of patents in the Brazils is founded upon two Ordinances; the first bearing date 28th April, 1809, and the second 23th August, in the ninth year of the Independence of the Empire. Most of the regulations appear to be derived from the European practice. A limited term is allowed for working the invention; a correct and a complete specification is required to be deposited before the patent is granted. The extent of the privilege is limited, according to the nature of the invention, and varies from five to twenty years: this may, however, be lengthened, by an application to the Court of Chancery. In order to encourage the importation and advancement of manufacturing industry, the raw material, requisite to work a new invention, may be imported duty free; and certain premiums are annually granted to such branches of manufactures as may be deemed worthy of such bounty. The following is a translation of the Ordinances above referred to:—

I, THE PRINCE REGENT, make known to all who may see this present ordinance, having the authority of a law, that the first and principal object of my paternal care being to promote the public welfare of my faithful subjects, and having, with that view, established liberal principles for the prosperity of this State of Brazil; such principles being essentially necessary for promoting agriculture, stimulating commerce, and advancing navigation; so that all may become more extended and proportionate to the magnitude of this State—bearing in mind that the establishment of these liberal principles may create some diminution of the trade of the Kingdom of Portugal, although, eventually, an extended commerce will be the effect of the freedom of trade I have established, which increase must compensate, with interest, for the disadvantage temporarily suffered by certain branches of manufacture—being desirous not merely to remedy these inconveniences, but also to extend the mercantile navigation and the commerce of the inhabitants of all parts of my dominions—having heard the opinion of the ministers of my council, and other persons devoted to my service—for the amplification and renewal of sundry provisions already existing, and for maintaining a watchful vigilance over the public and private prosperity of my subjects, which I desire to aid and pro-

mote, because on it depends the greatness and consideration of my royal crown and the nation, I am pleased to determine as follows :—

I.—All raw materials, serving as the basis of any manufacture, shall be exempt from the payment of any entrance duty in all the custom houses of my dominions, when the manufacturer purchases them for the use of his own works ; he being only required to shew that he consumes them all for the purposes of his business, and being subject to such examination and enquiry as may be judged necessary by the Royal Junta of Commerce, for guarding against fraud and the embezzlement of my royal custom house duties. The same exemption shall be enjoyed by those manufacturers who may purchase the productions of my States, subject to the payment of any duty, which duty shall be remitted in favour of the said manufacturers, for the purpose of extending manufacturing industry.

II.—All native manufacturers shall be exempt from the payment of any duty on exporting goods from my States, and all manufacturers of the kingdom shall be exempt from the payment of duty on entering my dominions in Brazil, or elsewhere ; the owners being merely required to prove, by certificates and satisfactory evidence, that the merchandise is of Portuguese manufacture, and to state the warehouse from whence it is brought.

III.—All the clothing of my troops shall be purchased from the native manufactories of the kingdom, and from those which may henceforth be established in Brazil, when the capital, which is now better employed in the cultivation of the soil, shall be applied with more advantage to the arts ; and military clothing shall never be purchased from foreign manufactories, except in the event of the fabrics of the kingdom of Brazil being inadequate to supply the public want. I have urgently recommended the President of my Royal Exchequer always to aid, by prompt payments, the manufacturers of my States, so that they may be enabled to supply my armies, and promote by this means the extension and increase of national industry.

IV.—In the recruiting, which is generally made by the State, every care must be taken to moderate the number of recruits in those places where it is known that hands are required for agriculture and the arts ; and I urgently recommend generals and captains, engaged in recruiting, to proceed in that matter with the utmost circumspection, representing to me all cases they may deem worthy of consideration.

V.—The most ready means of promoting any rising branch of manufacture, which may be extended by the introduction of new, useful, but expensive machinery, being to furnish funds which may have the effect of animating the capitalists engaged in such manufacture, a gratuitous gift has for this purpose been

conceded by the State. I have been pleased to order, that from the National Lottery of the State, which I annually permit to be established, there shall be drawn every year the sum of sixty thousand cruzados, to be applied, either altogether or separately, to the benefit of those manufactures and arts which most need assistance, particularly those of wool, cotton, and silk, and also iron and steel works. And those who receive this gratuitous gift, shall not be under any obligation to repay it; they shall only be required to contribute their active efforts to extend the manufacture which may have been aided through the effect of my royal consideration for the public welfare. And in order that these gratuitous donations may be made annually, and without fail, the Royal Junta of Commerce shall every year furnish me with a true and correct list of the manufactures of the kingdom, and shall specify those which are particularly deserving of the donation, and mention the sum which ought to be granted to them.

VI.—It being very proper that the inventors and introducers of any new machine, or invention in the arts, should enjoy an exclusive privilege (besides the right they may have to the pecuniary donation which I have been pleased to establish for the benefit of manufactures and arts), I ordain that all persons laying claim to such privilege shall present the plan of their new invention to the Royal Junta of Commerce, who, having ascertained the claim to be genuine and well founded, will grant the exclusive privilege for the space of fourteen years, on condition of its being made public at the expiration of that period, so that the whole nation may thus reap the fruit of the invention. I moreover ordain, that an accurate revisal be made of those privileges already conceded; those which have expired being made public as above determined, and all those revoked which may have been obtained by false allegations, or without well-grounded claims.

VII.—For promoting and advancing the maritime commerce of my faithful subjects, I have thought fit to determine, that only one-half the duty, fixed in the custom-houses of my States, shall be paid on all products and raw materials, which may be required by the owners of new ships, for the building and fitting out of such ships, such as Brazil-wood, nails, ropes, sail-cloths, pitch, and tar, transported in native vessels, and being subject to the most rigid examination and certification, for the purpose of preventing fraud, or the embezzlement of my royal custom-house duties.

Accordingly, I order the Court of the Desembargo do Paço e da Conciencia e Ordens; the President of my Royal Exchequer; the Council of my Royal Treasury; the Royal Junta of Commerce, Agriculture, Manufactures, and Navigation, and all the other Courts of the Kingdom and of this State of Brazil, and all persons who may be concerned in the knowledge and execution

of this ordinance, to fulfil and obey the same, and to cause it to be fulfilled and obeyed, without regard to any contrary laws or orders, all which I hereby derogate, as though a special mention were made of each ; and this is to have the same authority as a charter passed by the Court of Chancery, supposing no other to be passed by it, and it is to stand in force more than a year, notwithstanding any law to the contrary. Given in the palace at Rio de Janeiro, the twenty-eighth of April, one thousand eight hundred and nine.

PRINCE :: COUNT DE AGUIAR.

Ordinance, having the authority of law, by which your Royal Highness has been pleased to exempt from duty those raw materials serving as the bases of any native manufactures, and to grant, as a gratuitous gift, the sum of sixty thousand cruzados to those manufacturers who may most stand in need of such aid ; making also other provisions in favour of the manufacturers, and of maritime commerce, in the manner set forth above.

For Your Royal Highness's inspection : drawn up by
JOAO ALVARES DE VAREJAO.

Registered in the Office of the Secretary of State for the Home Department, in Book I. of Laws, Ordinances, and Royal Charters, folio 100. Rio de Janeiro, the third of May, one thousand eight hundred and nine.

JOAQUIM ANTONIO LOPEZ DA COSTA.

WE, Dom Pedro the First, by the grace of God, and the unanimous call of the people, Constitutional Emperor and Perpetual Defender of Brazil, make known to all our subjects, that the General Assembly has decreed, and we assent to, the following Law.

ART. 1.—The law secures to the discoverer or inventor of an object or method of utility to industry, the property and exclusive use of his discovery or invention.

ART. 2.—The improver of a discovery or invention, enjoys the right of discoverer or inventor in such improvement.

ART. 3.—The introducer of a foreign method of labour shall obtain a premium, proportionate to the utility of the invention, and the difficulty of introducing the same.

ART. 4.—The right of the discoverer or inventor shall be confirmed by a patent, gratuitously granted, on payment of only the expences of the Seal and the passing ; and in order to obtain the same, the claimant shall,—

1st.—State, in writing, that the object referred to is his own invention or discovery.

2nd.—He shall deposit, in the public archives, an exact and faithful exposition of the methods and processes which have been employed, with plans, drawings, or models, explanatory thereof, and without which the said matters or processes could not be sufficiently illustrated.

ART. 5.—The patents shall be granted, according to the nature of the discovery or invention, for a space of time varying from five to twenty years : a longer period can only be granted by a law.

ART. 6.—If the Government should purchase the invention or discovery, it must be made public ; but, in the case of a patent only having been granted, the invention may remain unpublished until the expiration of the grant, when the inventor or discoverer shall be bound to make his invention known.

ART. 7.—The infringer on a patent right shall forfeit the instruments and productions, and shall pay a fine equal to one-tenth of the value of the manufactured productions, with the costs ; besides being still liable to make indemnification for loss and damage. The instruments, productions, and the fine, are to be transferred to the owner of the patent.

ART. 8.—The holder of a patent may make use of it in any manner he may prefer, either by working it himself or transferring it to one or more persons.

ART. 9.—In case two or more persons should concur in the means whereby any object may be obtained, or should at the same time agree in soliciting a patent, it shall be granted to all of them.

ART. 10.—The patent ceases and becomes void :—

1st.—When it is proved that the truth has been departed from by the grantee, or that it was imperfectly described by the concealment of matter essential to the exposition or declaration made for obtaining the patent.

2nd.—When it is proved to the person styling himself the inventor or discoverer that the invention or discovery has been printed and described in the same manner as that in which he has represented it as his own.

3rd.—When the grantee does not carry into practice the invention or discovery within two years from the grant of the patent.

4th.—When the discoverer or inventor obtains for the same discovery or invention a patent in a foreign country. In that case, however, the said introducer or inventor shall be entitled to the premium stipulated in Art. 3.

5th.—When the commodity manufactured or fabricated shall be declared injurious to the public, or contrary to the laws.

6th.—The patent right shall be without effect against those who, anterior to the grant thereof, shall have made use of the same invention or discovery.

ART. 11.—The Government is authorized to order the passing of patents conformably with the provisions of the present law; the Procurator of the Crown, of Finance, and of the National Sovereignty being always heard.

ART. 12.—All laws and regulations to the contrary are hereby revoked.

Hereupon we order all the Authorities, whose duty it is to promulgate and to carry into execution the above law, to obey it, and cause the same to be obeyed, and vigilantly to watch its execution in all its parts. The Secretary of State for the Home Department shall cause it to be printed, published, and circulated.

Given in the Palace of Rio de Janeiro, on the twenty-eighth day of the month of August, one thousand eight hundred and thirty, being the ninth year of the Independence of the Empire.

(Signed) The EMPEROR,

VISCONDE DE ALCANTARA.

Charter of Law whereby Your Imperial Majesty orders the execution of the Decree of the General Legislative Assembly, which Your Majesty has been pleased to sanction, and in which are stipulated the conditions and the means of securing to the discoverer or inventor of a useful machine or process, the property and the exclusive use of his discovery or invention, in the form here above set forth.

For Your Majesty's Imperial inspection: drawn up by
LUIZ JOAQUIM DOS SANTOS MARROCOS.

Registered in folio 129 of book 5, of the Register of Laws, Patents, and Charters. Office of the Secretary of State for the Home Department, August 30th, 1830.

ALBINO DOS SANTOS PEREIRA.

ANTONIO JOSE DE CARVALHO CHAVES.

This Charter of Law was published in the High Court of Chancery of the Empire of Brazil. Rio de Janeiro, September 4th, 1830.

FRANCISO XAVIER RAPOZO DE ALBUQUERQUE.

Registered in folio 1, book 2, of the Register of Laws, High Court of Chancery of the Empire, September 4th, 1830.

MANOEL DE AZOVEDO MARQUEZ.

A NOTICE OF SOME IMPORTANT ARTICLES CONTAINED
IN BERZELIUS' "RAPPORT ANNUEL SUR LE PROGRES
DE LA CHIMIE."

*Presented to the Royal Academy of Sciences at Stockholm,
March 31, 1843.*

Hydrobromic and Hydriodic Acid.—M. Millon (*Jour. de Pharm. et de Chim.* I. 299) has proposed a modification of the ordinary method. He employs the bromide or the iodide of potassium in the place of the pulverized glass, and thus obtains a much larger quantity of the hydracids, because the salt employed is decomposed by the phosphoric acid, which it converts into phosphate of potash. The proportions that react are, 2 ats. of the salt of potash, 5 ats. of the bromine or iodine, 1 at. of phosphorus, and 7 ats. water. To obtain the hydrobromic acid, M. Millon employs 15 grammes of the bromide of potassium and a little water, to which he adds 25 grammes of bromine, and 2 grammes of phosphorus, cut up in small pieces. The hydrobromic acid soon begins to be so rapidly disengaged, that it becomes, at times, necessary to plunge the vessel in cold water to check the action. When the disengagement of gas becomes slow, it is aided by a little heat. In the preparation of the hydriodic acid, it is necessary to heat from the beginning, and the escape of gas is very uniform.

A New Method of Precipitating the Sulphurets of Metals.—M. Himley (*Ann. der Chim. und Pharm.* XLII. 347) has made known a new method of precipitating the metallic sulphurets without the use of sulphuretted hydrogen. It consists in mixing the metallic solution with the hyposulphite of soda; this salt, in most cases, produces no precipitate, but if hydrochloric acid is added, the metallic sulphuret is immediately precipitated. All the metals precipitated by sulphuretted hydrogen, are also precipitated by this method.

To separate Manganese from Zinc dissolved in a Liquid containing an Excess of Hydrochlorate of Ammonia.—M. Otto (*Ann. der Chem. und Pharm.* XLII. 347) has proposed the following method for separating manganese from zinc, when they exist together in a solution containing much sal-ammoniac. Ammonia is added, and the metals are precipitated by a current of hydro-sulphuric acid; if acetic acid be added to the precipitates, the sulphuret of manganese will be dissolved alone.

To make Caoutchouc impermeable to Gas.—M. Chevreul (*Journ. für Pr. Chem.* XXVI. 35) has shewn that linseed oil placed on the external surface of the caoutchouc renders it impermeable to gas.

The Influence of Colored Light upon Plants.—The result of these experiments (*Journ. de Chim. Med.* VIII. 645) has shewn

that plants prosper better under blue and violet colored glasses, and less under yellow and green, and do not grow at all under red glasses. It is known that when plants are exposed behind ordinary glasses, they direct themselves toward the light; now, under the yellow and green they do not incline at all, and under red glasses they bend in an opposite direction to that from which the light comes. If these facts are confirmed, they will be very interesting, and merit the attention of those physiologists occupied with the study of vegetation.

Succinic Acid.—M. Ronalds has produced succinic acid by prolonged action of nitric acid upon wax, and also by the action of the same acid upon spermaceti. In this latter case, adipinic and pimilinic acids are formed; but by a continued action of the nitric acid, both of them may be converted into succinic acid.

Angelical Acid.—M. Buchner, Jr. (Buchner's Report, XXVI. 263) has discovered in the root of the *Angelica archangelica*, a new acid, which he has called angelic acid, and which resembles valeric acid.

Opianic Acid.—MM. Wöhler and Liebig (Ann. der Chem. und Pharm. XLIV. 126) have discovered a new vegetable acid, which is the product of the action of dilute sulphuric acid and oxide of manganese upon narcotine. It is called opianic acid.

New Acid from Sugar.—M. Malaguti (L'Institut, No. 450, p. 279) has found that when starch sugar is heated in a solution of acetate of copper to a temperature between 80° and 100° cent., so that the oxide of copper is precipitated, there is a disengagement of carbonic acid and the formation of a new acid.

Preparation of Quinine.—M. Calvert (Journ. de Chim. et de Pharm. II. 388) has called attention to the solubility of quinine in lime water or the milk of lime, which is the reagent ordinarily used to precipitate the bases from their combination with the hydrochloric acid used to extract them from the bark. He proposes to avoid this inconvenience by almost saturating the hydrochloric acid with carbonate of soda, driving off the carbonic acid, and precipitating with caustic soda, which dissolves hardly a trace of quinine. In this manner a much larger quantity of quinine is obtained, and this excess more than repays the cost of the reagent. Lime water does not dissolve cinchonine, and therefore may be used to detect the presence of it in quinine, taking care to use a considerable portion of lime water.

Quinoline.—M. Gerhardt (Journ. für Pr. Chem. XXVIII. 76) has examined the reaction of potash upon several of the vegetable bases, aided with a high temperature, and he has found that a volatile and oleaginous base is produced, which is called quinoline.

Cinchovatine.—M. Manzini (Ann. de Chim. et de Phys.) has discovered in the bark of the *Cinchona ovata* a new vegetable base, which he has called cinchovatine.

An Easy Method of Preparing the Ethers of the Vegetable Acids.—M. Gaultin (Ann. der Chem. und Pharm. XL. iii.) proposes a method for preparing directly these ethers without the intervention of any mineral acid. He heats the acid in a tubulated retort to as high a temperature as possible without decomposing or subliming it; then lets fall the alcohol drop by drop upon it; the ether is immediately formed, and distils over. He has experimented with oxalic, citric, succinic and benzoic acids.

Mucilaginous Meteorite.—M. Mulder (Scheik Arderzock, 1st St. 34) has examined the mucilaginous matter that is found sometimes in the morning upon the grass, the origin of which is not known. It has been considered a *tremella* swollen by the dew,—also supposed to be a body thrown from some falling star. The experiments of M. Mulder put this question beyond a doubt, in proving that it is an animal mucilage, which has been swollen by water to the greatest degree, so that the solid mucilage constitutes but a very small portion of the mass. He found in it bone earth, a trace of proteine, a little lactate of soda, and common salt. The elementary analysis gave—

Carbon	50.53	Nitrogen	9.27
Hydrogen	6.53	Oxygen	33.67

As to the origin of the mucilage, M. Mulder supposes that it is a mucilage of frog's spawn, swollen by water.

T E A.

(From the forthcoming Supplement to Dr. Ure's Dictionary of Arts, Manufactures, and Mines.)

THIS well-known plant has recently acquired peculiar interest among men of science, both in a chemical and physiological point of view. In its composition it approaches, by the quantity of azote it contains, to animalized matter, and it seems thereby qualified, according to Liebig, to exercise an extraordinary action on some of the functions of animals, especially the secretion of bile. The chemical principle characteristic of tea, coffee, and cocoa beans, is one and the same, when equally purified, from whichever of these substances it is extracted; and is called indifferently either Theine or Caffeine. Mulder takes it from tea, by treating the evaporated extract by hot water, with calcined magnesia, filtering the mixture, evaporating to dryness the liquor which passes through, and digesting the residuum in ether. This solution being distilled, the ether passes over, and the theine remains in the retort. This principle is extracted in the same way from ground raw coffee, and from *guarana*, a preparation of the seeds of *Paullinia*; highly valued by the Brazilians. Theine, when pure, crystallizes in fine glossy needles, like white silk, which lose, at the heat of boiling water, 8 per cent. of their weight, constituting its two atoms of water of crystallization.

These needles are bitter tasted. They melt at 350° Fahr., and sublime at 543°, without decomposing. The crystals dried at 250° dissolve in 98 parts of cold water, 97 of alcohol, and 194 parts of ether. In their ordinary state, they are but little more soluble in these menstrua. Theine is a feeble base, and is precipitable by tannin alone from its solutions.

Mr. Stenhouse prepares theine by precipitating a decoction of tea with solution of acetate of lead, evaporating the filtered liquor to a dry extract, and exposing this extract to a subliming heat, in a shallow iron pan, whose mouth is covered flatly with porous paper, luted round the edges, as a filter to the vapour, and surmounted with a cap of compact paper, as a receiver to the crystals. In this way he obtained, at a maximum, only 1·37 from 100·00 of tea. But M. Peligot, from the quantity of azote, amounting to about 6 per cent., which he found in the tea leaves, being led to believe that much more theine existed in them than had hitherto been obtained, adopted the following improved process of extraction:—To the hot infusion of tea, subacetate of lead and then ammonia were added; through the filtered liquor a current of sulphuretted hydrogen was passed, to throw down all the lead, and the clear liquid being evaporated at a gentle heat afforded, on cooling, an abundant crop of crystals. By re-evaporation of the mother liquor, more crystals were procured, amounting altogether to from 5 to 6 out of 100 of tea.

The composition of theine may be represented by the chemical formula, C₈, H₅, N₂, O₂; whence it appears to contain no less than 29 per cent. of nitrogen or azote.

Peligot found, on an average, in 100 parts of—

	Parts soluble in boiling water.
Dried black teas	43·2
— green teas	47·1
Black teas, as sold	38·4
Green teas, ditto	43·4

Tea, by Mulder's general analysis, has a very complex constitution; 100 parts contain—

	Green.	Black.
Essential oil (to which the flavour is due)	0·79	0·60
Chlorophyle (leaf-green matter)	2·22	1·84
Wax	0·28	
Resin	2·22	3·64
Gum	8·56	7·28
Tannin	17·80	12·88
Theine	0·43*	0·46
Extractive matter	22·80	19·88
Do. , dark-colored	—	1·48
Colorable matter, separable by muriatic acid	23·60	19·12
Albumine	3·00	2·80
Vegetable fibre	17·08	28·32
Ashes	5·56	5·24

* This constituent is obviously much underrated.

Since the proportion of azote in theine and caffeine is so much greater than even in any animal compound, urea and uric acid excepted, and since so many different nations have been, as it were, instinctively led to the extensive use of tea, coffee, and chocolate or cocoa, as articles of food and enlivening beverage, which agree in no feature or property, but in the possession of one peculiar chemical principle, we must conclude that the constitution of these vegetable products is no random freak of nature, but that it has been ordained by Divine Wisdom for performing beneficial effects on the human race. Hitherto, indeed, medicine, a conjectural art, exercised too much by men superficially skilled in the science of nature, and the slaves or abettors of baseless hypotheses, has laid tea and coffee generally under its ban, equally infallible with the multitude as that of the Pope in the olden time, and has denounced their use, as causing a variety of nervous and other *nosological* maladies. But chemistry, advancing with her unquenchable torch into the darkest domains of Nature, has now unveiled the mystery, and displayed those elemental transformations of the organic functions in the human body, to which tea and coffee contribute a salutary and powerful aid.

Liebig, in his admirable researches into the kingdoms of life, has been led to infer that the bile is one of the products resulting from the decomposition of the animal tissues, and that our animal food may be resolved, by the action of oxygen, so amply applied to the lungs in respiration, into bile, and urea, the characteristic constituent of urine.

When the consumption of tissue in man is small, as among mankind in the artificial state of life, with little exercise, and consequently languid digestion, assimilation, and decomposition, the constant use of substances rich in azotised compounds, closely analogous to the chief principle of the bile, must assist powerfully in the production of this secretion, so essential to the healthy action of the bowels and other organs. Liebig has fully proved that the bile is not an excrementitious fluid, merely to be rejected, as a prejudicial inmate of the system; but that it serves, after secretion, some important purposes in the animal economy, being, in particular, subservient to respiration.

I shall conclude these remarks, perhaps more appropriate to a work on chemistry than to the present, by stating the relation between *theine* and the animal product *taurine*, the characteristic constituent of bile.

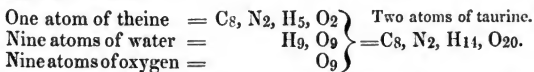

The letters C, N, H, O, denote carbon, nitrogen or azote, hydrogen, and oxygen; and the figures attached to each, the number of atoms; one atom of carbon being 6, one of azote 14, one

of hydrogen 1, and one of oxygen 8; from which the composition of the bodies, theine and taurine, may be easily computed for 100 parts. Now, supposing one-tenth of the bile to consist of solid matter, and this solid matter to be choleic acid (resolvable into taurine, but different from it), which contains 3·87 of nitrogen; then 2·8 grains of theine would afford to 480 grains of bile (supposed solid, or 4,800 grains in its ordinary state) all the nitrogen required for the constitution of *taurine*, its peculiar crystalline principle.

It may be remarked here, however, with regard to tea and coffee, that while they agree in the main feature, they differ in some others, and especially in the large proportion of tannin in the former, and its non-existence, according to my experiments, in the latter, notwithstanding the statement of its presence in many chemical works. Hence, tea may act injuriously in persons of *Cretian* habits*; while coffee has no constipating power, however much it may cause excitement and heat under certain idiosyncrasies.

A pure, agreeable, and convenient concentrated preparation of tea and coffee has been recently made the subject of a patent, by Mr. Staite; which preparation I can recommend as being made from the best articles in the market, by a perfectly wholesome apparatus and process. The patentee has printed a little explanatory pamphlet on the object of his improvement, from which the following extracts are taken:—

“The quantity of tea grown and consumed in China cannot be ascertained, but the consumption of Europe and America may be taken as follows:—

Russia	6,500,000 lbs.
United States of America	8,000,000
France	2,000,000
Holland	2,800,000
Other countries	2,000,000
Great Britain	50,000,000

71,300,000lbs. or 31,830 tons.

“The number of tea-dealers in the year 1839 was, in England, 82,794; in Scotland, 13,611; and in Ireland, 12,744; making a total of 109,179. It is presumed that, in consequence of the increased population, their number at present must exceed 120,000.

“The observations of Liebig afford a satisfactory explanation of the cause of the great partiality of the poor not only for tea, but for tea of an expensive and superior kind. He says, ‘We shall never certainly be able to discover how men were first led to the use of the hot infusion of the leaves of a certain shrub

* Titus, chap. i. v. 12.

(tea), or of a decoction of certain roasted seeds (coffee). Some cause there must be, which will explain how the practice has become a necessary of life to all nations. But it is still more remarkable, that the beneficial effects of both plants on the health, must be ascribed to one and the same substance (*théine* or *cafféine*), the presence of which in two vegetables, belonging to natural families, the products of different quarters of the globe, could hardly have presented itself to the boldest imagination. Yet recent researches have shewn, in such a manner as to exclude all doubt, that *théine* and *cafféine* are in all respects identical.' And he adds, 'That we may consider these vegetable compounds, so remarkable for their action on the brain, and the substance of the organs of motion, as elements of food for organs, as yet unknown, which are destined to convert the blood into nervous substance, and thus recruit the energy of the moving and thinking faculties.' Such a discovery gives great importance to tea and coffee, in a physiological and medical point of view.

"At a meeting of the Academy of Sciences, in Paris, lately held, M. Peligot read a paper on the Chemical Combinations of Tea. He stated, that tea contained essential principles of nutrition, far exceeding in importance its stimulating properties; and shewed that tea is, in every respect, one of the most desirable articles of general use. One of his experiments on the nutritious qualities of tea, as compared with those of soup, was decidedly in favour of the former.

"Coffee is grown in Brazil, Cuba, Hayti, Java, British West Indies, Dutch Guiana, States of South America, French West India Colonies, Porto Rico, Sumatra, Ceylon, Bourbon, Manilla and Mocha. Brazil produces the largest quantity, 72,000,000 pounds weight; and the other states and colonies according to the order in which they are enumerated, down to Mocha, which produces the least, or 1,000,000 pounds; making a total of 346,000,000 pounds, equal to the consumption of the enormous quantity of 2,900 tons weekly, or 150,800 tons per annum.

"From the official returns, the quantities of coffee exported in one year from the different places of production were 154,550 tons:—

	TONS.		TONS.
To France	29,650	Spain	1,000
U. S. of America.	46,070	Prussia	930
Trieste.	9,000	Naples and Sicily	640
Hamburg	20,620	Venice	320
Antwerp	10,000	Fiume	170
Amsterdam	8,530	Great Britain (average	
Bremen	4,500	of 10 years)	18,250
St. Petersburg.	2,000		<hr/>
Norway and Sweden	1,470		154,550
Denmark	1,400		

“ Every reflecting man will admit, that articles of such vast consumption as tea and coffee (amounting together to more than 185,000 tons annually), forming the chief liquid food of a whole nation, must exercise a great influence upon the health of the people, and that any discovery which tends to the purification of these alimentary drinks, rendering them more wholesome, without rendering them less agreeable, is a great boon conferred upon society.”

LIST OF REGISTRATIONS EFFECTED UNDER THE ACT FOR PROTECTING NEW AND ORIGINAL DESIGNS FOR ARTICLES OF UTILITY.

- Sept. 27. *Thomas Moulson*, of Sheffield, for an improved carpenter's brace head.
28. *Clarke & Timmins*, of No. 28, Exeter-row, Birmingham, for a loose convex washer for castors.
28. *John Fenton*, of Ockbrook, near Derby, for a design for gloves and mitts.
28. *Henry Spicer*, of Regent-street, Westminster, for an aquatic life-preserver.
- Oct. 1. *Edward Thomas, Lord Thurlow*, of Ashfield Lodge, Ixworth, Suffolk, for a quadruple breeching and expanding rose for fire-engines.
1. *Edward Thomas, Lord Thurlow*, of Ashfield Lodge, Ixworth, Suffolk, for an improved bit.
 2. *William M. Nicholson*, of Newark, for a compound wedge for varying the distance between rollers in grinding, crushing, pressing, and other similar machines.
 3. *John Hutchings*, of Bath, for a bootmaker's blocking machine.
 4. *John Tarring*, of No. 23, Charles-street, Middlesex Hospital, for "The Ventilator," specially adapted for smoky chimneys.
 5. *George Miller Clarke*, of No. 55, Albany-street, Regent's Park, for a complete mortar or night light.
 5. *W. Young*, of Queen-street, Cheapside, for a design for the vase of an Argand lamp, of glass or earthenware.
 9. *Benjamin Wigg Hickling*, of Noble-street, for an improved shirt collar.

- Oct. 11. *James Boyd*, of No. 78, Welbeck-street, Cavendish-square, for "The hermetic chimney valve."
14. *Thomas Grinham*, of No. 24, York-road, Lambeth, for an economical kettle.
16. *William Blenkiron*, of Wood-street, Cheapside, for an improved shirt collar.
19. *Edwin Edward Cassell*, of Millbank, for a design for raising and lowering the wicks of lamps.
22. *John & Edward Butler*, of Walsall, for a cigar case.
22. *James Jones*, of Bow-street, Covent Garden, for a pendent gas-lamp.
22. *Richard Edmunds*, of Banbury, for a seed depositor.
23. *William Hodgson*, of No. 149, West-street, Sheffield, for "The tailor's instrument," for ascertaining the exact shape of the bodies and waists of all sizes of persons, proportioned and disproportioned, without rule or calculation, and forming the same on the cloth.
23. *John Mayow Hoskisson*, and *Charles Hoskisson*, of Wilnecote, Warwickshire, for a horse for making soles for drain tiles.
24. *William Reynolds*, of Friendly-place, Mile End, for a design for the circles and arcs of circles of nautical and astronomical instruments.
25. *Thomas Henry Harris*, of No. 15, Blackmore-street, Clare Market, for a portfolio.
29. *Joseph & Edmund Ratcliff*, of St. Paul's square, Birmingham, for a bookholder.

List of Disclaimers
OF PARTS OF INVENTIONS AND
Amendments
MADE UNDER LORD BROUGHAM'S ACT.

Disclaimer entered by *Joseph Cooper*, of Hoxton, in the county of Middlesex, Gent., to patent dated 28th March, 1843, for "certain improvements in the purification and clarification of sugar, which improvements are also applicable to the purifying and clarifying other articles of commerce." Filed 28th September, 1844.

List of Patents

That have passed the Great Seal of IRELAND, to the 15th of October, 1844, inclusive.

To Robert Davison, of Brick-lane, in the county of Middlesex, civil engineer, and William Symington, of East Smithfield, in the said county, Esq., civil engineer, for a method or methods of drying, seasoning, purifying, and hardening wood and other articles, either in a manufactured or unmanufactured state; parts of which are applicable to the preparation and desiccation of animal, vegetable, and mineral substances.—Sealed 24th September.

Peter Ward, of Albury, in the counties of Salop and Worcester, late of Westbromwich, in the county of Stafford, practical chemist, for an improvement in combining matters for washing and cleansing.—Sealed 15th October.

George Augustus Kollmann, of the German Chapel, St. James's Palace, in the county of Middlesex, Gent., for certain improvements in railways, and locomotive and other carriages.—Sealed 15th October.

List of Patents

Granted for SCOTLAND, subsequent to September 22nd, 1844.

To Peter Rothwell Jackson, of Strawberry Hill, near Manchester, engineer, for certain improvements in the construction and manufacture of wheels, cylinders, hoops, and rollers, and in the machinery or apparatus connected therewith; and also improvements in steam-valves.—Sealed 24th September.

Wilton George Turner, of Gateshead, in the county of Durham, Doctor in Philosophy, for an improved mode of directing the passage of, and otherwise dealing with, the nauseous vapours and other matters arising from chemical works in certain cases.—Sealed 25th September.

Thomas Fuller, of the firm of William Collier and Company, of Manchester, engineer, for certain improvements in machinery, tools, or apparatus for turning, boring, and cutting metals and other substances.—Sealed 30th September.

- Henry Oliver Robinson, of No. 12, Old Jewry, London, engineer, for certain improvements in steam machinery and apparatus for the manufacture and refining of sugar.—Sealed 1st October.
- Pryce Buckley Williames, of Llegodig, Montgomeryshire, North Wales, for certain improvements in the manufacture of artificial stone.—Sealed 9th October.
- Jean Baptiste Paul Chappé, of Manchester, spinner and doubler, for certain improvements in machinery or apparatus for spinning and doubling cotton and other fibrous substances.—Sealed 9th October.
- Jacob Samuda, of the Southwark Iron Works, engineer, and Joseph D'Aguilar Samuda, of the same place, engineer, for certain improvements in the manufacture and arrangement of parts and apparatus for the construction and working of atmospheric railways.—Sealed 10th October.
- William Clarke, of Nottingham, lace manufacturer, for improvements in machinery for manufacturing ornamented bobbin net or twist lace.—Sealed 15th October.
- William Cormack, of York-street, Commercial-road, London, manufacturing chemist, for a new or improved method or plan for purifying coal gas.—Sealed 15th October.
- Vice-Admiral Sir Graham Eden Hamond, Bart., K.C.B., of Norton Lodge, Yarmouth, for improvements in the mode of fastening on and reefing paddle-wheel float-boards or paddles,—being a foreign communication.—Sealed 15th October.
- George Augustus Kollman, of the German Chapel, St. James's Palace, London, for certain improvements in railways, and locomotive and other carriages.—Sealed 16th October.
- William Henry Ritchie, of Lincoln's Inn, London, for improvements in obtaining copper from ores,—being a foreign communication.—Sealed 17th October.
- Richard Roberts, of the Globe Works, Manchester, engineer, for certain improvements in machinery or apparatus for the preparation of cotton, wool, and flax; and also for spinning and doubling cotton, silk, wool, and other fibrous substances.—Sealed 19th October.
- John Grieve, of Portobello, Edinburghshire, engineer, for certain improvements in the production and use of steam, applicable to steam-engines.—Sealed 21st October.
- Robert Hazard, of Clifton, near Bristol, confectioner, for improvements in baths.—Sealed 21st October.

Pierre Armand Le Comte de Fontainemoreau, of Skinner's-place, Sise-lane, London, for a new mode of constructing barometers and other pneumatic instruments,—being a foreign communication.—Sealed 22nd October.

John Henry Rehé, of Moscow-road, London, surgeon, for improvements in the manufacture of starch and farinaceous food.—Sealed 22nd October.

New Patents

SEALED IN ENGLAND.

1844.

To Edward Coke Wilmot, of Haddenham, Bucks, for improved apparatus for warming beds, persons, carriages, and rooms. Sealed 26th September—6 months for enrolment.

James Malam, of Huntingdon, gas engineer, for certain improvements in purifying coal gas, and increasing its illuminating power, and preventing the circulation of it being impeded by frost. Sealed 26th September—6 months for enrolment.

Edwin Edward Cassell, of Mill Wall, Poplar, merchant, for a material or combination of material suitable for paving, piping, roofing, and most other purposes to which wood and iron are applicable. Sealed 26th September—6 months for enrolment.

Thomas Clark, of Wolverhampton, iron-founder, for an improved domestic convenience. Sealed 26th September—6 months for enrolment.

Sir George Steuart Mackenzie, of Coull, county of Ross, Bart., for an improvement or improvements in the manufacture of paper, and particularly for the purpose of writing and copying writings, and machinery for effecting the same; also the manufacture of a fluid or fluids to be used with the improved paper, in the manner of ink. Sealed 26th September—6 months for enrolment.

John Berkeley Cotter, of Dublin, Gent., for improvements in the preparation and manufacture of woven fabrics or tissues applicable to various useful purposes. Sealed 26th September—6 months for enrolment.

- Alexander Turnbull, of Russell-square, Doctor of Medicine, for a new mode or method of more expeditiously tanning hides and skins, of extracting and separating catechuic acid from the tannic acid in the catechu or terra japonica, used in tanning. Sealed 26th September—6 months for enrolment.
- Alexander Ramuz, of Frith-street, Soho, cabinet maker, for improvements in sofas, wardrobes, ottomans, bedsteads, and other apparatus for reclining or sleeping on, and in the construction of dining and billiard tables,—being a communication. Sealed 27th September—6 months for enrolment.
- James Carter, of Deabole, Cornwall, Gent., for improvements in cutting slate for roofing and other purposes. Sealed 27th September—6 months for enrolment.
- William Henry Ritchie, of Lincoln's-inn, Gent., for improvements in carding-engines,—being a communication. Sealed 27th September—6 months for enrolment.
- John Harcourt Quincey, of Old-street, Gent., for improvements in the manufacture of blinds and shutters. Sealed 27th September—6 months for enrolment.
- Samuel Cunliffe Lister, of Manningham, worsted spinner, for improvements in preparing and combing wool. Sealed 27th September—6 months for enrolment.
- William Thomas, of Cheapside, merchant, for improvements in looms,—being a communication. Sealed 3rd October—6 months for enrolment.
- Samuel Pritchett, of Charlbury, Oxfordshire, glove-maker, for certain improvements in cutting and making-up gloves. Sealed 3rd October—6 months for enrolment.
- Albert Daniel Hindley, of Berners-street, Oxford-street, carpet manufacturer, for improvements in the manufacture of carpets and other piled fabrics. Sealed 3rd October—6 months for enrolment.
- William Newton, of the Office for Patents, 66, Chancery-lane, civil engineer, for improvements in machinery for letter-press printing,—being a communication. Sealed 3rd October—6 months for enrolment.
- Obed Mitchell Coleman, of Fitzroy-square, Gent., for improvements in piano-fortes. Sealed 10th October—6 months for enrolment.
- William Henry Ritchie, of Lincoln's-inn, Gent., for improvements in obtaining copper from ores,—being a communication. Sealed 10th October—6 months for enrolment.

- John Bower Brown, of Sheffield, merchant, for improvements in combining cast-steel with iron, and in the construction of carriage springs. Sealed 10th October—6 months for enrolment.
- Joseph Eugene Chalbert, of Chancery-lane, Gent., for improvements in preparing materials to be used in making picture and other frames, and for architectural and other purposes. Sealed 10th October—6 months for enrolment.
- Henry Oliver Robinson, of Old Jewry, engineer, for certain improvements in steam machinery and apparatus for the manufacture and refining of sugar. Sealed 10th October—6 months for enrolment.
- George Hurwood, of Ipswich, engineer, for improvements in apparatus for moving and fastening windows. Sealed 14th October—6 months for enrolment.
- John Smith, of Salford, weaver, for certain improvements in the manufacture of fabrics suitable for ornament or dress,—being a communication. Sealed 14th October—6 months for enrolment.
- Adolphe Nicole, of Dean-street, Soho, watch-maker, for improvements in watches and chronometers. Sealed 14th October—6 months for enrolment.
- Sir Graham Eden Hamond, Bart., of Norton Lodge, Yarmouth, for improvements in the mode of fastening on and reefing paddle-wheels, float-boards, or paddles,—being a communication. Sealed 14th October—6 months for enrolment.
- William Clarke, of Nottingham, lace manufacturer, for certain improvements in machinery for manufacturing ornamental bobbin-net or twist lace, and other fabrics. Sealed 14th October—6 months for enrolment.
- Peter Borrie, of Princes-square, St. George's in the East, civil engineer, for certain improvements in the machinery for the manufacture of sugar. Sealed 17th October—6 months for enrolment.
- Arthur Parsey, of Spur-street, Leicester-square, artist, for improvements in obtaining motive power. Sealed 17th October—6 months for enrolment.
- Edouard Ginques, of Peckham, Gent., for improvements in printing on leather and skins,—being a communication. Sealed 17th October—6 months for enrolment.
- Jean Baptiste Paul Chappé, of Manchester, spinner, for certain improvements in machinery or apparatus for spinning and doubling cotton and other fibrous substances. Sealed 17th October—6 months for enrolment.

- Alexander Wright, of Hales-place, South Lambeth, engineer, for certain improved apparatus for measuring gas, water, and other fluids, and in the means of manufacturing the same. Sealed 17th October—6 months for enrolment.
- Frederick Herbert Maberly, of Stowmarket, Clerk, Stephen Geary, of Hamilton-place, New-road, architect, and Joseph Croucher, of James-street, Buckingham Gate, Gent., for certain improvements in the construction and arrangement of machinery or apparatus for clearing, cleansing, watering, breaking up, and raking of streets, roads, lands, and other ways. Sealed 17th October—6 months for enrolment.
- John Grieve, of Portobello, Scotland, engineer, for certain improvements in the production and use of steam, applicable to steam-engines. Sealed 17th October—6 months for enrolment.
- James Nasmyth, of Patricroft, Lancashire, engineer, and Charles May, of Ipswich, engineer, for improvements in working atmospheric railways, and in machinery for constructing the apparatus employed therein. Sealed 22nd October—6 months for enrolment.
- John Henry Rehé, of Moscow-road, surgeon, for improvements in the manufacture of starch and farinaceous food. Sealed 22nd October—6 months for enrolment.
- Frederick Ransome, of Ipswich, caster, for improvements in the manufacture of artificial stone, for grinding and other purposes, Sealed 22nd October—6 months for enrolment.
- George Osmond, of London-street, Tottenham-court-road, cabinet maker, for improvements in fastenings for doors, drawers, window sashes, and dining tables, and in apparatus for suspending looking glasses and other articles. Sealed 22nd October—6 months for enrolment.
- James Napier, of Hoxton, dyer, for improvements in treating mineral waters to obtain products thereof, and for separating metals from other matters. Sealed 22nd October—6 months for enrolment.
- Moses Poole, of Serle-street, London, Gent., for improvements in machinery for emptying privies and cesspools,—being a communication. Sealed 22nd October—6 months for enrolment.
- Henry Carbines, of Hayle, Cornwall, brazier, for certain improvements in fuses, cartridges, and other like explosive instruments. Sealed 24th October—6 months for enrolment.

CELESTIAL PHENOMENA FOR NOVEMBER, 1844.

D. H. M.		D. H. M.	
1	Clock after the sun, 16m. 17s.	—	Jupiter R. A. 23h. 40m. dec. 3. 42. S.
—	☽ rises 9h. 16m. A.	—	Saturn R. A. 20h. 18m. dec. 20. 18. S.
—	☽ passes mer. 4h. 16m. M.	—	Georg. R. A. 0h. 10m. dec. 0. 21. N.
—	☽ sets 0h. 9m. A.	—	Mercury passes mer. 23h. 48m.
10 39	Occul. 1 Cancri, im. 16h. 29m.	—	Venus passes mer. 21h. 6m.
2 6 44	♃'s first sat. will em.	—	Mars passes mer. 21h. 25m.
3 10 19	♃'s second sat. will em.	—	Jupiter passes mer. 7h. 56m.
5	☽ in ☐ or last quarter	—	Saturn passes mer. 4h. 35m.
—	Clock after the sun, 16m. 15s.	—	Georg. passes mer. 8h. 26m.
—	☽ rises 0h. 42m. M.	11 56	♃'s second sat. will em.
—	☽ passes mer. 7h. 22m. M.	17 1 31	☽ in ☐ or first quarter
—	☽ sets 1h. 49m. A.	9 0	♃'s first sat. will em.
6 22 51	♀ in conj. with the ☽ diff. of dec. 6. 37. N.	22 23	Juno in ☐ with the ☉
7 16 31	♂ in conj. with the ☽ diff. of dec. 5. 29. N.	—	Occul. G Aquarii, im. 6h. 22m.
8 12 35	♃'s first sat. will em.	18 2	♀ in Perihelion
9	☉ eclip. invisible at Greenwich	19 0 42	♃ in conj. with the ☽ diff. of dec. 6. 57. S.
9 20	♃'s second sat. will em.	—	2 32 ♃ stationary
17 1	♂ in conj. with the ☽ diff. of dec. 2. 14. N.	16 9	♃ in conj. with the ☽ diff. of dec. 5. 49. S.
10	Clock after the sun, 15m. 53s.	20	Clock after the sun, 14m. 5s.
—	☽ rises 7h. 19m. M.	—	☽ rises 1h. 53m. A.
—	☽ passes mer. 11h. 48m. M.	—	☽ passes mer. 8h. 43m. A.
—	☽ sets 4h. 9m. A.	—	☽ sets 2h. 38m. M.
7 4	♃'s first sat. will em.	23 0 11	♂ in Aphelion
9 36	Ecliptic conj. or ● new moon	24	Total Eclipse of the ☽
18	☽ in Perigee	—	First contact 8h. 36m. } Mean time at
11 8 15	♃'s fourth sat. will im.	—	Middle 11h. 44m. } Greenwh.
9 33	♃'s fourth sat. will em.	—	Last contact 14h. 52m. }
12 20 35	♂ in the descending node	—	Mag. of the eclipse (☽ dia. = 1) 1.435, on the Southern limb
14 23 40	♃ in conj. with the ☽ diff. of dec. 5. 17. S.	10 56	♃'s first sat. will em.
15	Clock after the sun, 15m. 9s.	11 42	Ecliptic oppo. or ☉ full moon
—	☽ rises 0h. 2m. A.	—	Occul. ♁ 2 Tauri, im. 14h. 58m.
—	☽ passes mer. 4h. 50m. A.	—	Occul. ♁ 1 Tauri, im. 10h. 50m. em. 11h. 56m.
—	☽ sets 9h. 48m. A.	25	Clock after the sun, 12m. 42s.
8 23	♂ in sup. conj. with the ☉	—	☽ rises 4h. 23m. A.
16	Mercury R. A. 15h. 28m. dec. 19. 7. S.	—	☽ passes mer. Morn.
—	Venus R. A. 12h. 49m. dec. 3. 16. S.	—	☽ sets 7h. 58m. M.
—	Mars R. A. 13h. 9m. dec. 6. 17. S.	11	☽ in Apogee
—	Vesta R. A. 21h. 1m. dec. 22. 15. S.	21 30	♀ in conj. with ♂ diff. of dec. 1. 10. N.
—	Juno R. A. 9h. 36m. dec. 2. 16. N.	26 5 25	♃'s first sat. will em.
—	Pallas R. A. 17h. 21m. dec. 4. 23. N.	27 6 8	♃'s third sat. will em.
—	Ceres R. A. 17h. 41m. dec. 25. 37. N.	30	Occul. ♀ Cancri, im. 8h. 55m. em. 9h. 45m.

J. LEWTHWAITE, Rotherhithe.

THE
LONDON JOURNAL
AND
REPERTORY
OF
Arts, Sciences, and Manufactures.

CONJOINED SERIES.

No. CLVI.

RECENT PATENTS.

To JAMES HARDY, of Birmingham, in the county of Warwick, Gent., for certain improvements in the process of welding tubes, pipes, or hollow rods of malleable iron, by machinery.—[Sealed 28th March, 1844.]

THIS invention consists in substituting for the apparatus ordinarily employed for making iron pipes or tubes, (consisting of a pair of revolving grooved rollers, mounted in a suitable frame,) a series of three or more revolving grooved rollers, mounted in a frame one above another, between which (that is, between the lower one and the one next above it, and between this last one and the roller next above, and so on) the skelp, previously brought to a welding heat, is passed in succession, until formed into a welded tube of the desired size.

In Plate XIII., fig. 1, is a front view of a machine constructed according to this invention, with a set of three rollers and their appendages; fig. 2, is a back view; fig. 3, a side view; fig. 4, a transverse vertical section; and fig. 5, a partial back view, to exhibit some of the parts more clearly. A, B, C, are the rollers, which work in bearings in the standards D, D: motion is communicated to the axis of one of the

rollers from the steam engine or other prime mover, by means of a connecting shaft *h*, and the three rollers are caused to revolve together, at the same speed, by the pinions *e*, *f*, *g*, which gear into each other. Around each roller a number of grooves are formed, gradually diminishing in size from one end of the roller to the other. The grooves in the roller *b*, are larger than those in the roller *a*, and the grooves in the roller *c*, are smaller than those in the roller *a*, so that, by the combination of the three rollers, two sets of gradually diminishing apertures (nearly circular) are formed, of which the grooves in the lower set are slightly larger than the grooves in the upper set. Or, the centre roller *a*, may have two sets of grooves in it, one set corresponding with those in the roller *b*, and the other set corresponding with those in the roller *c*: in this case the apertures formed by the grooves would be circular. *i*, is the mandril that supports the skelp or partly finished tube, while it is being passed through the largest apertures formed by the grooves of the rollers; and *n*, *o*, are two discs, fastened upon the stem of the mandril, which come in contact with the plates or stops *j*, *k*, so as to retain the mandril in its proper position when the skelp is being acted on by the rollers. The plates or stops *j*, *k*, are supported at a suitable distance behind the rollers on a standard *l*, connected to one of the standards *d*, by a rod or bolt *m*.

The movement of the mandril, to bring it opposite the upper and lower apertures between the rollers, is effected by means of a semi-cylindrical trough *p*, carried by arms *q*, *q*, on the horizontal axis *r*. This axis turns in bearings at the lower end of the framing *s*, suspended from the horizontal axis *t*, which is supported by the standard *l*, and bracket *u*. The hinder ends of the arms *q*, *q*, are connected by a handle *v*, and from each arm a pin *w*, extends, for the purpose of regulating the extent of the ascent or descent of the arms, by entering the notches in the plates or stops *x*, *y*, which are bolted to the standards *d*, and *l*.

The mode of operating with this machine is as follows:—The skelp *z*, (fig. 4), is taken from the furnace at a welding heat, and is then passed between the rollers *a*, *b*; the bulb of

the mandril *I*, supporting the skelp, and causing its interior to assume a truly cylindrical form. The tendency which the revolution of the rollers (in the direction of the arrows) has to push the mandril backwards, is resisted by the disc *o*, upon its stem, coming into contact with the stop *J*. When the whole of the skelp has passed on to the stem of the mandril, the latter is raised out of the notch in the stop *J*, by means of its handle, and drawn a short distance backwards from between the rollers *A, B*. The skelp and mandril are then raised to a position opposite the aperture between the rollers *A, C*, through the medium of the trough *P*, which is elevated by the workman depressing the handle *V*, and the mandril is then pushed forwards, so as to enter between the rollers *A, C*. By the revolution of the rollers *A, C*, the partly finished tube, which is still at a welding heat, is drawn between them from off the mandril, which is prevented from being drawn too far forward, by its disc *N*, coming against the stop *K*. The tube may now be passed through the remainder of the two sets of apertures formed by the grooves of the rollers, for the purpose of lengthening it; the trough *P*, being used for raising the tube to the upper apertures, as will be best understood on examining the dotted lines in fig. 5. To facilitate the passing and repassing of the tube between the rollers, a trough *P*, with its appendages, may be applied to the front of them.

The patentee states, that "four revolving grooved rollers may be used, one above the other, in the same manner as hereinbefore described respecting three such rollers; and instead of the axis of the three or more rollers being placed horizontally, they may, if preferred, be placed vertically, the rollers in that case standing up side by side, three, or four, or more in a row, with a similar arrangement to the revolving rollers of what are called vertical sugar mills for crushing sugar canes."

The grooves in the rollers may be made in such a manner as to produce hollow rods of various regular prismatic forms, as triangular, square, pentagonal, hexagonal, octagonal, &c., and such hollow rods may be used for ornamental railing, and other purposes, instead of solid iron rods of such forms.

The patentee claims "the improvements, hereinbefore described, in the process of welding tubes, pipes, or hollow rods of malleable iron, by machinery of the kind hereinbefore described, that is to say, three (or more) revolving grooved rollers combined together (in manner hereinbefore described), so as to constitute two (or more) pairs of such rollers, which are adapted for passing the heated iron through between them, in one direction, and then for repassing the same iron through again, in a contrary direction, for the purpose of welding the edges of the heated iron together during such passing, aforesaid, and then for repeating that welding without delay, during the repassing, aforesaid, and while the iron retains a welding heat. And also, a mandril being used (in manner hereinbefore described) during such welding, the heated iron being carried over and on to the stem of the mandril, at the first time of passing and welding, and then the heated iron being carried off from the said stem at the repassing and repetition of the welding, so as to leave the mandril by itself, without requiring any trouble for withdrawing it from the heated iron after the welding. And also means, hereinbefore described, being used for promptly transferring the heated iron, with the mandril in it, from opposite to that aperture of the revolving grooved rollers through which the heated iron has passed for the first time of passing and welding, and speedily conveying the said heated iron and mandril opposite to the other aperture, through which it is then to be repassed, for repeating the welding."—[*Inrolled in the Rolls Chapel Office, September, 1844.*]

To LEONARD BOSTWICK, of Fen-court, Fenchurch-street, in the city of London, merchant, for an invention of certain improvements in machinery or apparatus for sewing all kinds of cloth or other materials.—[Sealed 2nd April, 1844.]

THIS invention consists of a machine of a peculiar construction, whereby cloth or other materials may be sewn or fastened together by means of a needle and thread.

In Plate XV., fig. 1, represents a side elevation of the machine, with one of the side plates removed, in order to

expose the internal arrangement to view; fig. 2, is a sectional plan view of fig. 1; and fig. 3, is a transverse section of the same, taken in the line 1, 2. The machine is composed of a box or case *a, a*, containing a large toothed-wheel *b, b*, which is, through the intervention of the pinion *c*, driven by applying manual labour to the winch handle *d*. A small toothed-wheel *e*, is also mounted in the upper part of the frame-work, and gears into the large wheel *b, b*, as seen in fig. 1. The cloth, or material to be operated upon, is passed into the machine between the toothed-wheel *e*, and large wheel *b, b*, and by that means is formed into doubles or crimps, as shewn by the waving or undulating line in fig. 1. The needle *f*, is held stationary by the additional pinions *g*, and *h*, and wheel *i*, and is shewn detached at fig. 4: it is made in the peculiar form shewn in the figure, in order that it may be passed over the small pinion *h*, and be thereby always kept up to its work, and prevented from running out of the machine. The pinion *h*, is actuated by causing the spur-wheel *k*, on the axle of the wheel *e*, to gear into and drive the pinion mounted on the axle of the pinion *h*, outside the box or case, as seen in the sectional plan view, fig. 2. Upon referring to fig. 2, it will be seen that a groove is made in the peripheries of the large wheel *b, b*, and the small wheels and pinions *e, g, h*, and *i*, for the purpose of holding the needle steady, and in its proper position. It will be understood that the needle is always stationary, and has an eye formed at one end, at *f**, as in ordinary needles, for the purpose of holding the thread, which may either be loose, or run off from a ball or bobbin, as the operation of sewing proceeds. Thus, as the large wheel *b, b*, rotates, the doubles or undulations in the cloth are formed, and are taken up by the needle; and when the work has passed through the machine, it will be found that a running stitch has been produced. The length of the stitch is regulated by the fineness or coarseness of the gearing of the wheels *b, b*, and *e*.

The patentee observes, that it will be evident to any intelligent mechanic, that the arrangement of some of the parts may be varied, without departing from the nature of the invention: he does not, therefore, confine himself precisely to

the peculiar arrangement herein shewn and described, although the apparatus has been found to work satisfactorily; but he claims the arrangement of parts herein shewn and described, or any modification thereof, when applied for sewing cloth or other materials, particularly the employment of a bent or curved needle, as shewn; and also the method of forming or crimping up the cloth or other materials into doubles or undulations, by means of the teeth of wheels and pinions, and thereby passing the said cloth or other materials so doubled, on to the needle, and from thence to the thread.—[*Inrolled in the Petty Bag Office, October, 1844.*]

Specification drawn by Messrs. Newton and Son.

To JOHN LIONEL HOOD, of Old Broad-street, in the city of London, Gent., for an invention of an improved composition or mixture of metals, applicable to the manufacture of sheathing for ships and other vessels, bolts, nails, or other fastenings,—being a communication.—[Sealed 17th February, 1844.]

THIS invention consists in certain mixtures of copper, zinc, and lead, with or without the addition of a small proportion of antimony, tin, or iron, and in which mixture the copper exists in various proportions, up to 50 per cent.; the object being, to produce a compound which is capable of being rolled out into sheets, suitable for the purposes to which copper sheathing has hitherto been applied; and also for forming ships' bolts, nails, and other fastenings. The addition of a third or fourth metal to the ordinary ingredients of brass, (which are copper and zinc,) is for the purpose of altering the crystalline arrangement of the particles of the metallic compound, or brass metal, to enable the manufacturer to roll the same into sheets with a smaller proportion of copper than has hitherto been practised (by which means a much cheaper sheathing is produced than sheet copper, or the sheathing hitherto known as yellow metal), and also to form a compound which is capable of wearing well, yet containing a sufficient proportion of copper to render the surface of the plates

susceptible of oxidation at sea, and thereby poisonous, by the formation of the cupreous salts, so as to resist the attack and adhesion of barnacles and other marine animals, which would otherwise impede the rate of the ship's sailing.

The mixtures here chosen are in such proportion as to combine chemically, or in atomic ratio, taking the prime equivalent, copper, at 32, according to the authority of the late Dr. E. Turner, Professor of Chemistry at the University of London.

As an example of the requisite proportions to embody these conditions, the following compounds are given, in which the copper ranges from 40 to 50 per cent. :—

	Atoms.	or	per cent.		Atoms.	or	per cent.
Copper....	16	or	40·4	Copper....	16	or	41·0
Zinc.....	15	„	38·0	Zinc.....	15	„	38·0
Lead....	2	„	16·5	Lead....	2	„	16·5
Antimony .	1	„	5·1	Tin.....	1	„	4·5
			<hr/> 100·0				<hr/> 100·0
Copper....	8	or	41·4	Copper....	12	or	44·0
Zinc.....	8	„	41·4	Zinc.....	12	„	44·0
Lead....	1	„	17·2	Lead....	1	„	12·0
			<hr/> 100·0				<hr/> 100·0
Copper....	10	or	43·0	Copper....	14	or	44·8
Zinc.....	10	„	43·0	Zinc.....	14	„	44·8
Lead .. .	1	„	14·0	Lead....	1	„	10·4
			<hr/> 100·0				<hr/> 100·0
Copper....	8	or	43·8	Copper....	16	or	45·4
Zinc.....	7	„	38·3	Zinc.....	16	„	45·4
Lead....	1	„	17·9	Lead....	1	„	9·2
			<hr/> 100·0				<hr/> 100·0
Copper....	32	or	45·5	Copper....	32	or	46·5
Zinc.....	30	„	42·5	Zinc.....	32	„	46·5
Lead....	2	„	9·0	Lead....	1	„	4·7
Antimony .	1	„	3·0	Tin.....	1	„	2·3
			<hr/> 100·0				<hr/> 100·0

Recent Patents.

	Atoms.	or	per cent.		Atoms.	or	per cent.
Copper	10		46·0	Copper	8		46·0
Zinc	5	„	24·0	Zinc	6	„	35·0
Lead	2	„	30·0	Lead	1	„	19·0
			<hr/> 100·0				<hr/> 100·0
Copper	5	or	49·0	Copper	8	or	49·0
Zinc	2	„	19·5	Zinc	5	„	32·0
Lead	1	„	31·5	Lead	1	„	19·0
			<hr/> 100·0				<hr/> 100·0

Iron may also be employed, by forming a mixture in which 1 atom or 28 parts of the pure metal, are combined with any given number of atoms (or equivalents) of copper, the zinc being also employed in atomic ratio.

The foregoing mixtures are given merely as examples for the formation of metallic compounds, of different densities, to be employed in the construction of rods, bolts, nails, sheets, and other similar articles, suitable for marine and other purposes; but the patentee does not confine himself thereto, so long as the mixture is in definite proportions, atomic ratio, or chemical equivalents, and forming a compound in which the copper ranges in proportion, not exceeding 50 per cent. by weight; such proportions forming an economical and useful mixture for the manufacture of marine sheathing, rods, bolts, nails, and other fastenings, the same not having been hitherto used and employed for such purposes.

The best mode of manufacturing is,—first to melt the copper in any suitable furnace, and, when completely fused, to add the zinc, lead, and other metals (if others are employed), in small quantities at a time, so as to avoid “setting” or cooling down the copper below the point of fusion; waiting a sufficient time between each addition to allow the proportion last added to become properly melted and incorporated, and taking care to prevent, as much as possible, the loss of the zinc by volatilization; which object is usually effected by holding each plate or ingot of zinc down below the surface of the copper, by means of a wooden pole or iron tool, till it is completely melted, as is well known to the workmen employed in making brass and yellow metal.

Or the entire quantity of copper may be first melted, and the lead, or other metal, then added. When the mixture is sufficiently fluid, a wooden pole should be introduced into the melted metal, and the mixture stirred well, the pole being allowed to burn, so as to liberate the hydrogenous gases from the wood, similar to the modes generally adopted in "poling" copper, when refining that metal. A portion of charcoal may likewise be thrown on the surface of the melted metal, to prevent loss by oxidation; the same being regulated by the practical experience of the founder, who should be well acquainted with the usual modes of refining copper and other metals. When this is done, the zinc or spelter should be added, in the way previously pointed out, to avoid chilling the metal too much; and when the whole is properly fused, the charge should be "tapped" or "laded" out of the furnace without delay, into iron or other suitable moulds, to form plates of from one to two inches in thickness, which should be allowed to get cold, and then separated from the moulds, and brought to a red heat, in a suitable furnace. The plates must be then passed between the rolling cylinders to reduce them to the required thickness—stopping the rolling as the metal chills below the point of redness, and reheating it as often as it is found necessary; or the plates when reduced to about $\frac{1}{8}$ inch thickness may be rolled cold,—taking the usual precaution of annealing them in the furnace after every two or three times passing between the cylinders.

The furnaces and machinery may be such as that ordinarily employed in melting and rolling copper and brass, which are well known, and therefore require no particular description.

The patentee does not confine himself to the precise proportions herein set forth; but he claims the manufacturing of sheathing, rods, bolts, nails, and other fastenings, for marine and other purposes, from mixtures of the above-mentioned metals, in atomic ratio, in which the copper does not exceed the proportion of 50 per cent., as above described.—[*Inrolled in the Petty Bag Office, August, 1844.*]

Specification drawn by Messrs. Newton and Son.

To WILLIAM WARDROPER, of Welbeck-street, in the county of Middlesex, surgeon, for his invention of certain improvements in the forms or constructions of hooks and eyes for fastening dresses, and for other uses.—[Sealed 5th December, 1843.]

THIS invention consists in making hooks and eyes of such a form as will admit of their being easily connected and disconnected from each other, when required, and also will prevent them from becoming accidentally unfastened.

The peculiar forms which the patentee has found to answer these purposes most effectually, are shewn in Plate XIII. Fig. 1, represents a plan view; and fig. 2, an edge view of one of the improved hooks and eyes connected together. Figs. 3, and 4, are a front and edge view of the hook; and figs. 5, 6, and 7, are front, edge, and sectional views of the eye. It will be seen, by inspecting these last-mentioned figures, that that part of the eye which comes in contact with the hook is flattened and pressed out, as seen best at *a*, fig. 7, so as to present a broad surface to the opening of the hook, when connected; but by turning the eye up, at right angles, or nearly so, a narrow edge is brought opposite the opening of the hook, and may then be easily detached therefrom. The shape of the hook may be varied, according to the taste or will of the manufacturer, as shewn in figs. 8, 9, 10, 11, 12, 13, and 14: the only precaution that it is necessary to observe, in the construction or formation of the hooks is, that the entrance or opening should be made narrower than the part *a*, of the eye, so as only to admit the same sideways. The shape, or configuration of the eye may also be varied, without departing from the nature of this invention; the principle of which consists in flattening and widening the part *a*, of the eye, and contracting the entrance of the hook, to prevent the fastenings from becoming disconnected accidentally, as above described.—[Inrolled in the Petty Bag Office, June, 1844.]

Specification drawn by Messrs. Newton and Son.

To THOMAS MARTIN, of *Withybush, near Haverford-west, in the county of Pembroke, clerk, for his invention of certain improvements in the construction of slated roofs, flats or floors, tanks or cisterns, or reservoirs for water, and in pipes, tubes, or channels, of the same materials, for the conveyance of water.*—[Sealed 22nd May, 1844.]

THIS invention consists, Firstly,—in the construction of roofs, flats, or floors, by combining squares or slabs of slate together, and attaching them to the boards or rafters in such a manner that the contraction of the timber will have no effect in disturbing the joints or junctions of the slate; and, Secondly,—in combining slabs and other forms of slate, hereafter described, for the purpose of holding water and other fluids, and also for conducting the same from one place to another.

In Plate XIV., three methods are shewn of combining slabs or squares of slate together, by which means the contraction of the planks and rafters of a roof, or floor, is prevented from affecting the slate covering. Fig. 1, represents a portion of a boarded roof, in which square slabs or blocks of slate *a, a, a*, from half an inch to three quarters of an inch thick, are sunk. In the centre of these blocks a pin or tranel *b*, is cemented, which projects out from the under side of the block, as shewn at the cross section, fig. 2, for the purpose of being inserted in a hole in the boards or planking *c*; this hole is of a rather larger diameter than the pin *b*, to allow of the contraction and expansion of the wood. *d, d, d*, are a series of squares of slate, cemented together in the manner shewn at figs. 3, and 4; fig. 3, being a plan view of a portion of a roof, constructed according to this invention; and fig. 4, a cross section of the same. These squares of slate are so placed on the boarded roof (after the blocks *a*, are inserted in the boards), that one corner of the four adjoining slates comes immediately over the block of slate *a*, (as shewn in the drawing) and are there attached by pins or trannels *e, e*, which enter the holes *f, f*, fig. 1, made about two-thirds of the way through the thickness of the block to receive them. The holes which pass from the upper to the

under square of slate must be larger in diameter than the pins or trannels, by a quarter or three-eighths of an inch, and previous to placing the squares of slate *a, a, a*, upon the boarded roof, these holes must be luted. The pins or trannels are likewise luted; and when inserted into the holes, a cement or composition, in a fluid state, is poured down the holes, and uniting with the composition at the joints of the squares, a perfect and indestructible mass is formed. Blocks and squares of slate, arranged and cemented together, as above described, may be applied directly to the rafters of roofs, without using boards or planks, and likewise to the joists and framing of flats or floors.

Fig. 5, represents, in plan view, a portion of a roof, constructed of rows of square slates, cemented together; and fig. 6, a side view of the same. Each row, it will be seen, laps over that which is below it, and the junctions of the slates are arranged so as to "break joint." The rows of slate are united together by pins or trannels, which pass through the laps of the slates into holes in the boards of the roof, made larger than the pins (as shewn at *b*, fig. 2,) to allow for the contraction and expansion of the wood, as before explained.

Another modification of this improved roof is shewn at figs. 7, 8, and 9; fig. 7, being a plan view; fig. 8, an edge view; and fig. 9, an underneath view of the same. *a, a*, are longitudinal slabs of slate; and *b, b*, the squares, which are attached thereto by pins or trannels, and cement. These slabs are affixed to the roof by the pins or trannels, shewn in the drawing, which pass through the squares of slate, and the slabs, and enter the wood, as above explained.

The second part of this invention, which relates to the construction of tanks and reservoirs for holding water, and pipes or channels for conveying the same, is shewn by the following figures. Fig. 10, is an elevation of a square tank, cistern, or reservoir; and fig. 11, a plan view of the same. A number of square slabs of slate, cut to any required size, are connected together at their edges, as before mentioned, and upon them are cemented other slabs of slate, in such a manner as to break joint. Four such combinations of slate

being made, will form the sides of the reservoir, or cistern, and a similar one is to form the bottom.

Around the bottom of the tank or cistern are grooves *a, a*, in which the sides *b, c, d*, and *e*, are cemented. To the vertical edges of the sides *b*, and *d*, upright grooved pieces of slate *f, f*, are affixed by trannels and cement, and the other sides *c*, and *e*, of the tank are secured thereto in like manner. *g, g*, are leaden rivets passed through the bottom, at the outside of the grooves, to prevent the laminæ from splitting.

In the drawings of the specification, a method of constructing a continuous line of trough is shewn, the sides of which may form obtuse or right angles to the bottom; but such troughs being put together on the same principle as the tank or cistern, it will be unnecessary to describe them further.

Figs. 12, 13, 14, and 15, shew the manner in which the patentee constructs pipes, tubes, or channels, for conducting water from one place to another. Having prepared any suitable number of blocks of slate, hollowed into a semi-cylindrical form, as shewn at fig. 12, he first joins two of them together, as at fig. 13, by means of cement, and pins or trannels *a, a*, which run through both blocks. In the ends of the pipe, tube, or channel, thus formed, a circular hollow *b*, is made, as shewn at fig. 14, which circle has an opening to the outside of the pipe, as at *c*. *d, d*, are vertical holes, leading down to horizontal holes *e, e*, which are made to receive half the length of an iron rod or wire *f*, (see fig. 13.) Another couple of blocks being similarly prepared, and joined together, as above mentioned, are ready to be connected to the former couple. This is effected by inserting the iron rods or wires *f, f*, into corresponding holes *e, e*, and by pushing up the part *A*, until it comes up flush with the part *B*, the junction is effected, as shewn at fig. 15. A fluid cement is then poured into the opening *c*, and flowing round the circle *b*, the joint is made airtight, and impervious to the escape of water.

Into the holes *d, d*, melted lead is poured, which, flowing into the holes *e, e*, firmly secures the rods *f, f*, in their place, and thus connects the pipes *A*, and *B*, securely together.

The composition which the patentee prefers for uniting the sections of slate employed for all the above-described purposes, consists of equal portions of carbonized coal tar and rosin, and a ninth part of linseed oil, melted and mixed together.

The patentee claims the peculiar arrangements of slabs and blocks of slate, cemented and pinned together as above described, for the construction of roofs of houses, and other erections requiring the same. Also the mode of constructing tanks, cisterns, or reservoirs, for holding water, as above explained; and lastly, the method, as above described, of constructing pipes, tubes, or channels, for holding water, and conducting it from place to place, whether such pipes or channels be made circular in the inside, and of two pieces, as shewn in the drawing, or of any other suitable form or number of blocks or slabs of slate, and connected together as above described.—[*Inrolled in the Petty Bag Office, November, 1844.*]

Specification drawn by Messrs. Newton and Son.

To JOHN HOLLAND BUTTERWORTH, of Rochdale, in the county of Lancaster, cotton spinner, for his invention of a certain apparatus, applicable to preparation machines, used in the spinning of cotton and other fibrous materials.
[Sealed 20th March, 1844.]

THIS invention consists in a revolving apparatus, placed over the mouth of a can, such as is used for the reception of slivers, which apparatus receives the sliver of cotton, or other fibrous materials, in the state it leaves a carding-engine, a drawing-frame, or a slubbing-frame, and disposes it in a can, in coils; so that when such coiled sliver reaches from the bottom of the can to the apparatus, that part of the sliver which is subsequently passed out of the apparatus presses upon, and, by the aid of the apparatus, condenses the other coiled part in the can; so that, by this invention, a sliver of cotton, or other fibrous material, may be disposed in a can, or other suitable receptacle, in coils, and condensed to any

degree required, without elongating, crimping, or otherwise damaging it, for the subsequent operations used in spinning.

In Plate XIII., fig. 1, is a vertical section through the middle of the revolving apparatus, placed over the mouth of a can, and below a pair of calender rollers, from which it is receiving the sliver, and passing it into the can; fig. 2, is a plan of the upper side of the apparatus, part of which is shewn in section in fig. 1; fig. 3, is a side view of fig. 2; fig. 4, is a front view of another arrangement of the revolving apparatus; fig. 5, is a plan view of the same; fig. 6, is a front view of a further modification of this apparatus; and fig. 7, is an end view of the two calender rollers, and parts of the apparatus shewn in fig. 6. In fig. 1, *a*, represents the calender rollers; *b*, the sliver; *c*, a skew bevil-wheel, fixed on, and driven by the axis of the lower calender roller; *d*, is a skew bevil-wheel, which takes into and is driven by *c*. This wheel *d*, and the spur-wheel *e*, are fixed upon the same axis *f*, which is hollow. *B*, are rods rising from the floor of the room, to which they are fixed; between the rods the cans *c*, or other suitable receptacles for the sliver, are placed. *g*, is a short cylinder of metal, which has two projecting bosses on the outside; each boss having a hole through it to receive one of the rods *B*, upon which rods the bosses are fastened by screws, and hold the cylinder *g*, in its working position. A bearing *h*, which carries the shaft *i*, is also fixed upon one of the rods *B*, by screws, upon which shaft the hollow axis *f*, works. The cylinder *g*, has a belt or ring *j*, fixed within it, which belt or ring has a groove, and a number of teeth *k*, forming a bevil-wheel on its upper side. The plate *D*, has a short cylinder *l*, fixed on its under side. This cylinder descends, and rests upon the bottom of the groove in the ring *j*, in which groove it works. Around the cylinder *l*, are cast a number of teeth, forming a spur-wheel, which wheel takes into and is driven by the spur-wheel *e*. *E*, is a circular plate, with a short cylinder fixed at its upper side, which extends to the plate *D*, by which cylinder the two plates are kept at a proper distance from each other. The central portion of this plate *E*, is made lower than the part around it, for the purpose of distributing the coils of sliver in the can in a spiral form, when such coils

reach so high as to be acted upon by it. There is an opening in the plate *E*, for the sliver to be passed through to the can. The plate *E*, is screwed to the plate *D*, so that they revolve together. In fig. 2, *m*, is a short shaft, supported so that it can revolve in a bearing *n*. On one end of the shaft *m*, is a bevil-wheel *o*, which takes into the fixed bevil-wheel *k*, and on the other end is a spur-wheel *p*, which takes into and drives the spur-wheel fixed on the axis of the roller *q*. At the other end of this axis is fixed the spur-wheel *r*, which takes into and drives the spur-wheel *s*, affixed to the axis of the other roller *t*. *u*, and *v*, are conducting rollers. An endless band of leather *z*, (see fig. 1,) passes partly round the rollers *t*, and *u*, and another endless band *z*, passes partly round the rollers *q*, and *v*. The bands of leather have strips of brass running across them, on the outside, parallel to the rollers. The under surface of the top endless band, and the upper surface of the lower endless band, run in contact, and the sliver passes from the rollers *A*, through the trumpet mouth *w*, between the rollers *q*, and *t*, between the endless bands, and the conducting rollers *v*, and *u*, through the opening in the plate *E*, into the can *c*. The four rollers *q*, *t*, *v*, and *u*, are supported in necks or slots in the bearings *x*, which are fixed to the under side of the plates *D*, and the surfaces of the endless bands *z*, run at the same speed as the surfaces of the calender rollers *A*.

It will be evident, from the foregoing description, that when the calender rollers *A*, are set in motion, a rotary movement will be given to the plate *D*, in the direction of the arrows (see fig. 2,) through the wheels *c*, *d*, *e*, and *l*, and a revolving motion will be given by the wheels *k*, *o*, to the rollers *q*, and *t*, and to the endless bands *z*, which receive the sliver from the rollers *A*, and deliver it in coils into the can. When the coiled sliver reaches to the plate *E*, the delivering endless bands continue to pass more of the sliver on the top of that coiled in the can, until the whole of the contents of the can become as much compressed as is required.

In fig. 4, the revolving apparatus is shewn, with the sliver passing from the calender rollers *A*, between a ball and a grooved pulley, and through an opening in the plates *D*, and

ε, into the can. Fig. 5, is a top view of fig. 4. In fig. 6, another arrangement of the revolving apparatus is shewn, with the sliver *b*, passing through a trumpet mouth *z*, which is placed over the centre of the apparatus, through another trumpet mouth *w*, through two calender rollers *3*, and through an opening in the plates *ν*, and *ε*, into the can. Fig. 7, is an end view of the two calender rollers, and parts of the apparatus shewn in fig. 6. Those parts of the apparatus by which rotary motion is given, so as to deposit the sliver in coils in a can, are the same in all the figures.

The patentee claims the revolving apparatus, combined and arranged as hereinbefore described, and which is applicable to preparation machines used in the spinning of cotton and other fibrous materials.—[Inrolled in the Inrolment Office, September, 1844.]

To EDWARD HILL, of Harts Hill, Dudley, in the county of Worcester, ironmaster, for improvements in the manufacture of railway and other axles, shafts, and bars.—
[Sealed 14th May, 1844.]

THESE improvements in the manufacture of railway and other axles, shafts, and bars, consist in forming the central parts of such articles of bars, which exhibit in their transverse section the figure of a cross, as seen in Plate XIV., at fig. 1. The spaces *a, a*, are to be filled with other bars *b, b*, fig. 2, if the shaft is to be cylindrical, or with the bars *c, c*, fig. 3, if the shaft is to be square, and the whole is then welded together. By using filling-pieces of various shapes, shafts of any desired form may be produced; and instead of only one filling-piece, two or more filling-pieces (of smaller dimensions) may be inserted into each space *a*. Although the patentee generally makes the centre bar and filling-pieces of iron, yet, if desired, steel may be used, in combination with iron, either in forming the centre bar or filling-pieces.

It is not necessary that the bars *b, c*, should fill the spaces *a*, as they may be formed suitably for leaving the parts near the centre hollow. In some cases, the shaft or axle may .

consist of the centre bar alone, the spaces *a*, being only filled in at those parts where the axle turns in bearings; or the centre bar may be made strong enough to admit of those parts being turned which are to work in bearings, without any filling-pieces being required.

The patentee does not claim the rolling of bars of angle iron, each offering in its transverse section the form of a cross, that having been done before, for other purposes. But he claims the mode of manufacturing railway and other axles, shafts, and bars, by applying, as the central part thereof, bars, each offering the figure of a cross in its transverse section, as above described.—[*Inrolled in the Inrolment Office, November, 1844.*]

To NICHOLAS TROUGHTON, of Swansea, in the county of Glamorgan, Gent., for improvements in dressing ores requiring washing.—[Sealed 23rd June, 1843.]

THIS invention relates to the apparatus employed for washing ores; and consists in constructing and working the sieves, containing the same, in such a manner, that the water is not only caused to rise through the sieves, as they descend, but flows over the surface of the ore, in a horizontal direction, or nearly so, carrying the lighter or refuse matter onwards, and leaving the heavier metallic ore behind.

In Plate XIV., fig. 1, is a longitudinal section, and fig. 2, a transverse section, of the apparatus employed by the patentee. *a*, is the frame of the sieves, closed on three sides; and *b, b, c, c*, are bars, to which the pieces of wire-cloth *d, d*, constituting the sieves, are attached; the sieves (which are each composed of two inclined planes of wire-cloth) being separated from each other by the bars *b, b*. The under part of the frame is closed on all sides by the plates *e, e, f, f*; and at one end of the frame two flap-valves *g*, are mounted. *h*, is a tank or vessel containing water, in which the sieves are worked with a quick up-and-down motion, by the following means:—Across the frame *a*, two straps *i, i*, are fixed, and to these are attached the rods *j, j*, that work through

holes in the frames k, k , and are connected by the rods l, l , with the arms m, m , projecting from the shaft n : this shaft receives motion from the shaft o , by the rod p , one end of which is jointed to the arm q , of the shaft n , and the other end is enlarged sufficiently to embrace the excentric r , on the shaft o ; at one end of the shaft o , is a fly-wheel s , and at the other end a pulley t , around which passes an endless band u , from the drum v , on the shaft w : this shaft is driven by a steam-engine or other prime mover.

The ore, in a broken state, is placed in the hopper x , and descends therefrom, on drawing back the slides x^1, x^1 , into the compartments y, z , of the sieves; then, by the quick up-and-down motion of the sieves, which causes the water to rise through them, the ore will, for the time, be suspended in the water, while the flow from the valves g , will carry forward the lighter particles, leaving the heavier ones in the compartments nearest the valves; so that, as the operation proceeds, the heavier particles of ore will be left in the lower part of the sieves; the lighter particles, or refuse, being carried onwards, and ultimately falling over the ends of the sieves. When the ore has been washed, the pin that connects the rod p , with the arm q , is withdrawn; the sieves are then raised, by introducing a bar 1, (represented by dots in fig. 2,) into the socket 2, and are kept in an elevated position, until the ore is shovelled out, by lashing the bar 1, to the hook 3.

The patentee claims the means, herein described, of dressing ores, by causing the lighter particles to be separated from the heavier ones, by moving the lighter particles, whilst suspended in water, to a greater and a greater distance, in a horizontal direction, from the heavier particles; and also combining therewith the use of a succession of sieves, whereby any metallic ore which may be carried forward from one sieve, by the currents, in a horizontal direction, or nearly so, may be deposited in a further sieve.—[Inrolled in the Inrolment Office, December, 1843.]

To GEORGE WILLIAM LENOX, and JOHN JONES, of Billiter-square, in the city of London, merchants, for improvements in the manufacture of sheaves and shells for blocks, and of bolt-rings or washers for the purposes of shipwrights and engineers.—[Sealed 10th April, 1844.]

THESE improvements consist in manufacturing sheaves and shells for blocks, and bolt-rings or washers, of malleable cast iron.

After the articles have been cast of the desired form, they are packed in an annealing vessel with Cumberland or Lancashire iron ore, and subjected to a red heat until properly annealed.

The blocks, thus made, are preferred to be coated with zinc.

The patentees claim, Firstly,—the mode of manufacturing sheaves and shells for blocks, by employing malleable cast iron; Secondly,—the mode of manufacturing bolt-rings or washers for shipwrights' and engineers' purposes.—[Inrolled in the Inrolment Office, October, 1844.]

To FRANCIS STUDLEY, of Shrewsbury, in the county of Salop, Gent., for an improved mill or apparatus for grinding grain, with or without sifter or dresser; also for cobling, bruising, crushing, cutting, splitting, or dividing seed, pulse, berry, or other articles.—[Sealed 24th February, 1844.]

IN Plate XIII., fig. 1, is an elevation of the improved mill; and fig. 2, represents the grinding parts, detached. *a*, is a solid wooden wheel; and *b*, a hoop or plate of steel, fixed thereon, having furrows, with sharp cutting edges, formed around it; but the breadth of the cutting surfaces is not stated: the wheel *a*, and hoop *b*, constitute what is called the "grinder." *c*, is a curved plate of steel, termed "the antagonistic grinder," having furrows on its face, inclining in the opposite direction to those on the hoop *b*. The plate *c*, is

attached, by a bolt and nut at *d*, to the wooden back *e*, which is firmly fixed to the framework of the mill; and by means of this bolt and nut, together with the bolts or screws *f, f*, the position of the plate *c*, may be regulated with great exactness. Motion is given to the grinder by turning the handle *g*, on the axis of the pinion *h*, which gears into a toothed-wheel *i*, upon the shaft of the wheel *a*.

j, is a hopper, having an opening at its lower extremity, furnished with a valve, through which the grain or seed passes into a small leather funnel *k*, fastened to the bottom of the hopper, and thence proceeds along the pipe *l*, into the cup *m*, suspended from the under side of the cover of the mill, and descends therefrom to the grinders. The funnel *k*, has a metal rim or nozzle, to which is fastened the cord *n*, that passes over the pulleys *o, o*; and the running of the grain may be stopped by the attendant pulling this cord, so as to bring the nozzle against the upper part of the pipe *l*. The cup *m*, has an exit valve in the lower part of it, by the adjustment of which the supply of grain to the grinders is regulated.

p, is a wire dresser or sifter, which is hung obliquely below the grinders, and is worked by a rod from a crank on the shaft of the wheel *a*; its upper end is suspended by a chain *q*, from the table *r*, and its lower end is supported by two chains *s, s*, one at each side; it strikes on a cross bar or stay *t*, by the action of the crank-rod, before mentioned, to clear itself more effectually. The flour passes through the dresser into the receiving drawer *u*, and the bran is discharged at its lower end.

In conclusion, the patentee says, "I claim, as of my invention, the construction and arrangement of mechanical parts, taken with reference to their combination, as it is described and set forth in the drawing and specification; and for the organized machine resulting from such construction and arrangement of parts, and the combination thereof, as herein described and set forth."—[*Inrolled in the Inrolment Office, August, 1844.*]

To RENÉ ALLAIRE, of *Charlotte-street, Fitzroy-square, in the county of Middlesex, dyer and cleaner, for improvements in cleansing gentlemen's garments.*—[Sealed 24th April, 1844.]

THE patentee states, that the object of his invention is the use of certain apparatus for applying the heat of steam for cleansing gentlemen's garments, and removing grease, tar, or oil spots; and also for drying garments which have been cleansed by washing or wetting.

The apparatus consists of hollow shapes, suitable for receiving the garments upon them, and made steam-tight. These shapes, on steam being admitted into them, will not only dry a washed and wet garment, but, at the same time, any grease or oil spots will be removed; the surface of the fabric is then brushed, and, if desired, the nap may be slightly improved with soft sharp wire cards.

In Plate XV., fig. 1, is a back view, and fig. 2, a vertical section of a hollow shape for a coat. The arm *a*, is moveable, and is first introduced into one sleeve of the coat, after which, the coat is placed on the hollow shape, and the arm is fastened in its place by the means represented in the enlarged sectional view, fig. 3. In the upper end of the arm *a*, is a groove, furnished with suitable packing, to receive the end of the stump *b*; the arm and stump are secured together by a rod *c*, with an oblong head, which is passed through suitable openings in the bars *d*, *e*, (fixed in the ends of the arm and stump,) and turned partly round, to prevent the return of the head; the rod *c*, is then firmly retained in its position, by screwing up the nut *f*, upon the rod *g*, which is connected to the rod *c*: to release the arm *a*, the nut *f*, is unscrewed, and, by means of the rod *g*, the rod *c*, is turned partly round, so as to admit of its oblong head being drawn through the bar *e*. Steam is admitted into the apparatus through the pipe *a*, and the water, resulting from its condensation, is drawn off from the body of the shape by the cock *h*, from one arm by the cock *i*, and from the other arm by the opening through which the rod *g*, passes, when it is allowed to escape by unscrewing the nut *f*: the air is permitted

to escape from the apparatus, on the admission of the steam, through the cocks *h*, *i*, and through a small groove in the face of the nut *f*, corresponding with the hole in the end of the arm.

Fig. 4, is a side view, and fig. 5, a front view of an apparatus to be inserted into the legs of trousers. Steam is introduced into it through the pipe *a*, and the water is drawn off by the cock *h*, through which also the air is allowed to escape, on the admission of steam.

The patentee claims the mode of cleansing gentlemen's garments, by applying the steam-heated apparatus within them, as herein described.—[*Inrolled in the Inrolment Office, October, 1844.*]

To HENRY DAVIES, of Norbury, in the county of Stafford, engineer, for certain improvements in the construction of vessels for conveying goods or passengers on water; also certain improved arrangements of machinery for communicating motion to such vessels.—[Sealed 25th January, 1844.]

THESE improvements are comprehended under three heads:—Firstly, in the peculiar construction of that part of a vessel which is immersed in the water, consisting of a channel or way for the flow of a current of water through the hull, under the deck, from head to stern; secondly, in the adaptation of rotary curved plates or paddles within the internal channel or water-way through the hull or lower part of the vessel; and thirdly, in the means of connecting vessels one to another, for the purpose of forming a train or series of passage boats, to be worked on canals or rivers.

In Plate XV., fig. 1, represents a longitudinal section of one of the improved construction of vessels, taken vertically through the middle, from head to stern; fig. 2, is a plan or horizontal view of the same, as it would appear when looking down upon the deck; the machinery below being represented, by dots, in its true position, as it would be seen if the deck were removed. Fig. 3, is a transverse section of

the vessel, taken vertically, near the prow; and fig. 4, is a similar section, taken near the middle of the vessel.

The whole of the framing of these vessels is preferred to be of plate iron, with wrought-iron bracings or standards; and the internal fittings may be of wood, or of any other materials that may be found suitable.

In constructing one of these improved vessels, a shell should be first formed for the lower part, resembling the hull, by connecting plates of iron by rivets, in the manner usually adopted in building ordinary iron boats.

The bottom of the improved vessel is formed in a straight horizontal line *a, a, a*, from end to end, and the sides *b, b*, parallel to each other. The deck *c, c, c*, which floats upon the water, is constructed, in like manner, of iron plates, rivetted to the sides, laying it upon a slight inclination downwards, from the head and stern, toward the middle, in order to give the vessel buoyancy. A portion of the deck, in the middle, is made horizontal, and parallel to the bottom *a, a, a*. The ends of this shell are left open, to afford a free water-way quite through, in a longitudinal direction, below the deck. The sides and deck may be firmly connected by rivets, and braced together by standards and transverse bars, if necessary; and the gunwales and fittings upon the deck may be made according as the character of the vessel may require. The precise angle of depression of the deck toward the middle, must depend upon the length and breadth of the vessel, in order to give it any required degree of buoyancy; and by the depression of the deck in the middle, that part of the water-way, or channel below, becomes contracted. Such is the improved construction of vessel, which constitutes the first head of the invention, the particular object of which will be hereafter explained.

In the sectional view, fig. 1, a series of longitudinal shafts *d, e, f*, are represented, as extending through the water-way of the vessel, under the deck; and these are connected, at their ends, by universal joints *g, g*, in order to enable them to revolve together at any required angle to each other. There are two series of these shafts, arranged parallel to the sides of the vessel, as will be seen by the dotted lines in the plan

view, fig. 2, and also in the transverse sections figs. 3, and 4. These shafts are supported by standards *h, h, h*, having bearings, in which the shafts are enabled to turn freely. Upon these longitudinal shafts there are affixed curved plates or inclined paddles *k, l, m*, and *n*. The paddles are severally formed to the figures of two half coils of a double-threaded screw, of considerable pitch, placed opposite to each other. The diameter of the plates or paddles must be as large as possible, in order to fill the water-way as nearly as may be; and the shafts must be as near together as will allow of the paddles revolving clear of each other, in the manner shewn at figs. 3, and 4. The pitch of the screw, giving the inclination of the curved plates or paddles *k*, and *n*, may be stated at five feet, and the diameter three feet six inches; in which case, with the proportion of contracted water-way shewn in the middle part of the vessel at fig. 1, the paddles *l*, and *m*, of two feet eight inches diameter, must have a greater inclination of the curved plates, say a pitch of six feet six inches. The object of this is, that the capacities of the spaces contained within the length of the pitch of the dissimilar paddles or screws, *k, l, m*, and *n*, shall be as nearly as possible equal to each other; and, therefore, in changing the obliquity and diameter of the paddles, this principle must be kept in view.

The patentee remarks, that having found it convenient to place his paddles in the inclined parts of the water-way, as seen in fig. 1, it may be necessary to form their peripheries in the curve of a frustum of a cone, in order that they may work as near the sides of the channel as possible, and thereby be fully acted upon by the whole current of the water.

Having described the construction of the improved vessel, and also the improved machinery for communicating motion to such vessel, the patentee proceeds to explain the principles upon which these improvements are employed for passing vessels along canals, rivers, and other waters; first observing, that these vessels may be propelled by steam power, with ordinary paddles, or other propelling apparatus; or by towing or other means commonly employed for that purpose.

Supposing the vessel, represented in longitudinal section at

fig. 1, should be towed by a horse, or propelled by any other ordinary means through the water, a partial vacuum in the water would necessarily take place toward the stern or after part of the vessel, and a pressure of the water against the prow or fore part. The vacuum and pressure, thus produced, will cause a current of water to pass in an opposite direction to the way of the vessel, to fill up the vacuum or space left by the progress of the vessel. This effect, it is well known, takes place in all cases where a vessel moves through the water.

If a vessel be constructed with a longitudinal channel through the middle of its hull, as represented in the drawings, and described above, the said current of water would pass through that channel; and if there were placed within the channel a series of four pairs of screw paddles, *k*, *l*, *m*, *n*, upon two continuous series of shafts, as exhibited, the current would cause those paddles to revolve.

Now the central part of the channel being contracted, the current of water, as the vessel passed along, would necessarily be accelerated in that contracted part of its course. It is from this cause that the pitch of the second pair of screws *l*, is required to be made greater than that of the first pair of screws *k*, in order to carry on the increased velocity of the water through the contracted part of the channel. When the current has passed through the contracted channel, it is met by the third pair of screws *m*, which diminishes its velocity, and being then met by the fourth pair of screws *n*, they take up the remaining portion of the velocity. Hence, between these last-mentioned two pairs of screws or paddles *m*, and *n*, the pressure of the water toward the hinder part of the channel is made exactly equal to that in the fore part, and the effect of the impeding vacuum at the stern of the vessel becomes annihilated—the power, thus obtained, being transmitted, through the shafts, to the two first pairs of screw paddles *k*, and *l*.

The improved mode of connecting boats together to form a train, is shewn at fig. 5, which is a partial plan view of two boats, connected together by a trough. The trough *a, a*, is made of wood or iron, as may be found most convenient, having

a flat bottom of about sixteen feet in length, with rectangular sides, corresponding, and nearly equal in breadth and depth, to the outside width and height of the boats intended to be connected. A vertical partition *b*, is placed in the middle of the trough, to keep the two ends of the boats asunder, and to prevent a current of water passing through it. The ends of the boats being inserted into this trough, as shewn, the two boats are attached together by a rope, chain, or any other contrivance, as shewn at *c*. When the train of vessels, as it is passing through the water, is required to turn at any angle from the straight line, the curved parts of their prow and stern turn in the trough (in the manner shewn by dots in the figure) to the required angle. The object of this mode of connecting a series of boats by means of such troughs, is to prevent the several boats producing separate displacements in the water, and causing them to form one continuous uninterrupted line of displacement in the water, as if they were one vessel.

The patentee does not confine himself to the precise form of vessel shewn in the drawing; but he claims any variety of construction in which the sides and bottom of the vessel, in the direction of its length, shall be parallel to a central line, drawn through the middle of the vessel, from end to end; such vessel having a contracted water-way or water-ways through it, in a longitudinal direction, for the purpose of giving it the required buoyancy; the extremities of which water-way shall each be equal in area to the external transverse section of the vessel, as far as it is immersed. He does not confine himself to the precise form of paddles or screws employed for regulating the passage of the current through the contracted water-way; but claims any variety of form of apparatus which shall be capable of regulating the current of the water through the channel, so that the pressure at the entrance and exit shall be equal. And lastly, he claims the construction of troughs by which the ends of the vessels are connected together, in the manner, and for the purposes above stated.—[*Inrolled in the Petty Bag Office, July, 1844.*]

Specification drawn by Messrs. Newton and Son.

To WILLIAM SNELL, of Northampton-square, in the county of Middlesex, Gent., for his invention of improvements in machinery for the manufacture of farina.—[Sealed 14th January, 1843.]

THIS invention consists, firstly,—in separating the farina of potatoes, by so arranging several sieves and machinery that the farina of potatoes, combined with water, may be caused to pass successively through such sieves; and, secondly,—in drying the farina of potatoes on surfaces of canvass or other woven fabrics.

The patentee describes his invention, as follows:—The potatoes, after being washed, are to be reduced to a fine pulp, by any convenient means. A revolving cylinder is preferred to be used, with parallel grooves, near together, to receive thin plates of steel, formed with fine teeth like saws; this cylinder, revolving quickly at the bottom of a hopper, in which the potatoes are placed, rasps the potatoes into fine pulp, which falls into a trough, placed below; but this mode of rasping the potatoes being old, forms no part of the invention. The pulp is then to be treated with water, and passed successively through a series of sieves.

The first sieve used is a rotary cylinder sieve, six feet long and three feet in diameter, covered with wire-cloth, having thirty holes to the inch. The fine pulp is regularly fed into one end, together with a constant supply of clean soft water; the sieve being slightly inclined, the water and pulp, as the sieve revolves, flow down through the sieve; the farina, with some impurities, flowing through the meshes of the sieve into a trough placed below. The first sieve is connected with a second sieve, similar to the first, by means of a cylinder about three feet long, within which are several projecting arms, fixed on the axis on which the sieves and cylinder revolve. By this means the pulp, passing through the cylinder, is beaten and opened, and the same will then flow on with water through the second inclined sieve, and the farina and some water will flow into the trough below, into which the farina of the first sieve flowed. The refuse pulp and water pass off, at the end of the second sieve, into a separate

trough, and are thus conveyed away into a vat or receiver. The farina, with a further supply of water, passes from the trough, which received it from the first and second sieves, into a third rotary cylindrical sieve, covered with wire-cloth of 50 holes to the inch. This sieve, like the former, is slightly inclined, and the farina and water passing through it are received into a trough below, which conducts them into a horizontal sieve, placed over a vat. The wire-cloth used for this sieve has 70 holes to the inch. In this vat the farina and water are to remain for about three hours, in order that the farina may precipitate; after which the water is drawn off with a syphon, and fresh water added, the whole being kept well stirred whilst run off from the bottom of the vat into a second vat, through another horizontal sieve, the wire-cloth of which should be of a finer quality. The farina and water are to remain for about three hours, for the farina to settle; the water is then to be drawn off and fresh water added, and the whole run off, whilst being stirred, into a third vat, and strained through a sieve of closely-woven silk. In this vat the product is to remain from eight to twelve hours, for the purpose of settling, after which the water is to be drawn off, and the farina dug out of the vat, and spread on canvass or other suitable woven fabric, stretched on frames, and supported at intervals with wires or bars. These frames are to be placed in a well-ventilated room, and the farina allowed to stand for about twenty-four hours, to drain and dry; after which it is to be broken into a granulated state, or rough small lumps, and spread on dry canvass or other fabric, stretched in frames, as above described, and subjected, in a room or chamber, to a temperature of from 80° to 100° Fahr., produced by any convenient means. The farina is then to be reduced to powder, by means of mallets, and again spread on to canvass or other fabric, stretched on frames in a room heated from 130° to 160° Fahr., where it is allowed to remain for about twenty-four hours. After this the farina is to be removed to a store room, to cool; and it will then be in a proper state to pack in casks or otherwise.

The patentee states, that he does not confine himself to the precise arrangement described, provided the peculiar cha-

acter of the invention be retained, whereby the pulp of potatoes can be submitted to a successive series of sieves and washings with water, in order to separate the farina from the refuse product of the potatoes, and also so long as the farina be dried by spreading it on canvass, or other woven fabric; nor does he claim the machinery described, when not combined and applied for the purposes described.

The patentee claims, Firstly,—the mode of combining the use of several sieves and other machinery, whereby the fine pulp of potatoes is successively submitted to be washed and separated by sieves, as above described; and, Secondly,—drying the farina of potatoes, separated by sieves and washing, on stretched canvass or other woven fabrics, as above described.—[*Inrolled in the Inrolment Office, July, 1843.*]

To ALEXANDER SIMON WOLCOTT, of City-terrace, City-road, in the county of Middlesex, machinist, and JOHN JOHNSON, of Manchester, in the county of Lancaster, machinist, for improvements in photography, and in the application of the same to the arts.—[Sealed 18th March, 1843.]

THE first part of this invention consists in an improvement in the process of making Daguerreotype pictures, by which means the gradation of light and shade is rendered more true to nature, and the picture is prevented from being so much injured, as it otherwise would be, from any error in the time of its exposure to the action of light. This is effected by allowing the light to act for a longer time than usual upon the plate, and then exposing it the vapour of iodine, bromine, chlorine, or a mixture of any of these, or any other vapour or vapours that will have the effect of lessening the deposit of mercury, when the plate is afterwards exposed to it. If the more volatile substances are employed, such as iodine, bromine, or chlorine, they should be very much diluted: for example, in using iodine, one part of a saturated solution of that substance, in water, mixed with two hundred parts more of water, will generally be found strong enough.

The iodine, or other substance employed, is put into a

vessel with a sliding cover, which extends so far beyond the side of the vessel as to admit of an opening being formed in that part, of nearly the same size as the plate, with a rabbet large enough to receive the plate; so that, after it has been inserted therein, the cover may be slid over the vessel, without allowing any of the vapour to escape. Or, the vessel may have a porous earthenware or other cover, that will allow the vapour to pass through it, and act on the plate, which should be brought very near to its upper surface; and, in this case, the vapour should be much stronger than when the sliding cover is used.

The second part of this invention consists in a camera, in which photographic pictures, on polished plates, may be copied by the scattered light from the surface of the plate, (that portion of the light which is reflected from the polished surface, at the same angle at which the incidental rays fall, being prevented from entering the lenses of the camera): in this camera may also be copied, in true perspective, pictures which are distorted in the perspective, by reason of the camera making an improper angle with the horizon, at the time of taking them, either accidentally, or in order to take in parts of a view that would not otherwise be seen.

In Plate XV., fig. 1, is a vertical section of the camera, taken through the centre; and fig. 2, is an enlarged sectional view of the two sets of lenses used therein. *a*, is the aperture for the admission of light to illuminate the picture desired to be copied; *b, b*, are tubes, containing the lenses *c, d*, and affixed to a partition *e*, which is made to slide into grooves in the sides of the box, at such distances from either end, as may be necessary to produce the various sizes of pictures required. *f*, is the picture to be copied; *g*, the plate on which the copy is to be made; *h, h*, the frames containing them; the frame of the plate *g*, being made to slide into grooves, placed at such distances, that, for every change in the position of the lenses, a sufficient change may also be made in the position of the plate, to preserve the focal distance. The aperture *i*, through which the light passes to the plate *g*, may be contracted when necessary, by means of the revolving diaphragm shewn at fig. 3. The lenses are

protected by the screen *j*, from the direct light, which enters the top of the box near *k*; and the edge *l*, is made so high, that a ray of light passing into the box close to that part, and falling on to the polished surface of the picture, close to its upper edge, will be reflected below the lenses.

When distorted pictures are to be copied in true perspective, the frames *h*, *h*, have other frames *m*, *m*, mounted within them, as represented in the horizontal section fig. 4; these frames move on vertical axes, in order that the faces of the plates *f*, *g*, which they contain, may be placed at various angles with the axis of the lenses. The picture is placed in its frame in such a manner, that the parts which are perpendicular in the object will be horizontal in the frame; and the end of the picture where the perspective is contracted is brought nearer to the lenses than the other end; then, supposing the copy is to be of the same size as the original, the plate *g*, is brought to the same angle with the lenses as the picture, as shewn at fig. 4; so that the ends of both plates that are nearest the lenses will be on the same side of the box. By this arrangement, those parts of the picture that are nearest to the lenses will be copied on that part of the plate *g*, which is farthest from them, and will be delineated larger than if the plates were parallel; whilst those parts of the picture that are farthest from the lenses will be copied on that part of the plate *g*, which is nearest to them, and smaller than if the plates were parallel; thus correcting the perspective in the copy. The sizes of the plates *f*, *g*, with regard to the focal distance, should be such, that when they are adjusted to the proper focal distance, either for pictures and plates of different sizes, or of equal sizes, the angle subtended from the lenses to the ends of the plate will not be more than thirty degrees.

The convex lenses *d*, may be made of common plate glass; but the plano-concave lenses *c*, should be formed of heavy flint glass, of about 3.5 specific gravity. For a focal distance of 7.7 inches, the following proportions will be found to answer:—The plane side of each lens *c*, is placed .78 inch distant from the aperture *i*; the other side, and likewise that side of the lens *d*, which is next to it, are made to a

radius of 1.78 inch ; the other side of the lens *d*, is made to a radius of 2.62 inches ; the diameters of the lenses are about $1\frac{1}{4}$ inch ; the thickness of each lens *c*, at the middle, is .06 inch, and that of each lens *d*, is .56 inch.

If the picture to be copied has been taken in a camera that did not contain a reflector, it would be reversed ; but the copy would be correct ; on the other hand, if a reflector has been used in the production of the picture, the copy is prevented from being reversed, by placing a reflector at *n*, and fixing the plate *g*, in a horizontal position at the top of the box. Although only metal plates have been mentioned, the copy may be obtained upon any material that is properly prepared to receive an impression by the action of light.

The clearest blacks being produced in a picture when the polishing of the plate has been finished by straight strokes in that direction which will be horizontal in the picture, it is requisite, in copying those which have been formed on plates, so polished, to place them in the box in such a manner, that the lines of the polish shall be perpendicular ; and, in all cases, in whatever direction the lines of polish in the picture are, they must be placed perpendicularly in copying : when the polish has been produced in curved, or otherwise than in parallel straight lines, that position should be chosen in which the largest portion of the lines will be perpendicular, or nearly so. If the lines of polish are perpendicular in a distorted picture that is to be copied, the frames *m, m*, must be mounted on horizontal axes in the frames *h, h* ; so that when the picture has been placed in its frame, with the polish marks perpendicular, the proper part may be inclined to the lenses, and that part must be at the top of the frame ; for if the top of the frame was turned from the lenses, it would allow the light to be directly reflected into them from the polished surface. The perpendicular position of the lines will cause the light, which falls on their inclined edges (the lines being only so many minute furrows), to be reflected below the lenses ; whereas, if the light was allowed to fall at right angles to the lines, a great portion of it would be reflected into them. The interior of the box, between the picture and the partition *e*, should be lined with black cotton velvet, or other-

wise darkened, to prevent any injurious reflection of light. By these means, if the polished surface of the picture was viewed from the place occupied by the lenses, no object, or light from objects bright enough to interfere with the operation, would be perceived in it; and, consequently, there would not be much light to act upon the plate or other material on which the picture is to be copied, and thereby injure the copy, which it is intended should be made by scattering lights from the rough surface produced by the adhesion of mercury (of which the picture is essentially composed) to the polished black ground of the plate.

The third improvement consists in an apparatus for exhibiting photographic pictures in a screen, in a darkened room.

Fig. 5, is a perspective view, and fig. 6, is a partial plan view, in section, of the apparatus. *a*, is the bottom of the apparatus, on which the cast-iron pieces *b*, *c*, are fixed; in a recess in the part *b*, a cylinder of lime *d*, is made to revolve slowly on its axis (by means of machinery beneath the bottom *a*), and upon it a jet of mixed hydrogen and oxygen gases is thrown, in the usual manner for producing light. *e*, is a conical opening in the part *b*; *f*, a set of achromatic glasses; and *g*, a polished circular metal plate, with a concave surface of such radius of curvature that the radius is just equal to the distance of the centre of the plate from the face of the piece *b*, and so placed, that the centre of the circle, of which the concave surface is a segment, shall be exactly midway between the opening *e*, and the centre of the lime *d*. The picture may be made upon the plate *g*, from the object itself; or it may be copied from a flat plate, using the camera shewn at fig. 1, but substituting, for the two compound lenses, two plano-convex lenses, of the same focal distance, and placing their plane surfaces towards the aperture *e*. As those parts of a photographic picture, on a polished plate, which are to represent the darker shades, are the most highly polished, they will be made to appear the brightest by a strong reflected light; hence it becomes necessary to reverse the polish of the different parts, so that the darkest parts shall become the least polished, and the lightest parts the most polished,

with the intermediate gradations. This is effected by putting on to the plate (which, in this case, forms a convenient dish to hold it) some sulphuric acid, and heating it slowly until the desired change takes place; then, after being washed and dried, it is ready for use.

The space between the parts *b*, and *c*, is enclosed at the sides by shutters, and on the top is placed a cover, with a large chimney, to produce a draft inwards through the aperture *h*, (which is just below the lower edge of the plate *g*, when it is fixed in its place,) to carry off the dust arising from the combustion of the lime, and prevent its being deposited on the picture. The part *b*, is prevented from becoming too much heated, by boring two passages *i, i*, through it, joining them together at the bottom by a tube, and connecting their upper ends, by two tubes, with a vessel of cold water.

The patentees prefer the diameter of the plate *g*, to be $4\frac{1}{2}$ inches, and the radius of the curve 4 inches; for these proportions, the achromatic glasses should be $2\frac{1}{2}$ inches in diameter, and of such degrees of curvature as is marked thereon, at fig. 6; the convex being of common plate glass, and the concave of flint glass, of about 3.5 specific gravity. The lenses are mounted upon a stand (fastened to the bottom *a*), in such a manner, that they may be adjusted to any requisite distance from the plate *g*, and to any angle that will give the best image.

The following is the action of the apparatus, when in use:—The light, which falls on the picture from the lime, is reflected to a point as much on one side of the centre of the plate as the lime is on the other; and as that point corresponds to the aperture *e*, the light from all parts of the plate passes through that aperture, and through the glasses *f*; and as the glasses have a focal distance just equal to their distance from the plate *g*, the light will form the image of the picture upon a screen.

The last part of the invention consists in a mode of arranging cameras, so that photographic pictures, on metal plates, may be copied by the direct reflected light from the polished surface of the plate, after it has been prepared so as

to make the dark parts reflect the least light, and the light parts the most, with the intermediate gradations.

Fig. 7, is a vertical section of a camera, constructed according to this part of the invention. a, a , are two sets of lenses, attached to a partition b , in the manner described with reference to fig. 1; c , the picture to be copied, placed at the proper angle to reflect the light, that falls on to it from the lens d , into the lenses a, a ; the focal distance of the lens d , being such, that the light, reflected from the picture, shall converge to a focus exactly at the aperture i , shewn in fig. 2; and no light must be admitted into the camera-box at any part, except where it passes from the lens d , to the picture. e , is the surface on which the picture is to be copied, being placed parallel thereto. This camera may be used with the light of the sky, or any other good even light, and with or without the lens d ; but its principal use is for converging the rays of the sun, or any strong artificial light, such as the hydro-oxygen (after reflection from the picture), through the aperture i , on to the surface e ; by which means, pictures can be formed on surfaces that are quite unfit for use in the camera in the ordinary way; and a small likeness taken on a very sensitive plate in the first instance, may be copied on to paper, even of that kind which is very inferior in sensitiveness, and, if required for the purposes of painting, a portrait of the size of life may be taken, by lengthening the box.

Pictures, prepared in the manner above mentioned, may be copied with the apparatus shewn at figs. 5, and 6; the prepared surface on which the copy is to be made being substituted for the screen.

The patentees claim, as their invention, Firstly,—exposing photographic plates, after the impression is made by light, to any vapour that will prevent the adhesion of as much mercury to the plate, in its after exposure to the vapour of mercury, as would have adhered if such previous exposure to vapour had not taken place. Secondly,—the mode of constructing cameras containing a chamber for the picture to be copied, and so constructed, that if the picture was viewed from the place occupied by the lenses, no object, or light

from objects bright enough to prevent a distinct view of all the parts of the picture, could be seen in the polished surface of the picture; also the mode of making cameras whereby a copy, in true perspective, may be obtained from a picture not in perspective, as described. Thirdly,—so arranging apparatus that photographic pictures may be shewn on screens, in darkened rooms. Fourthly,—so arranging apparatus that pictures on polished plates, which have had their surfaces acted on as described, may be copied by the light reflected by their polished surfaces into the lenses of the camera, according to the laws of reflection for polished surfaces.—[*Inrolled in the Inrolment Office, September, 1843.*]

To EDWIN WARD TRENT, of *Old Ford, Bow, rope-maker, for an improved mode of preparing oakum and other fibrous substances for caulking ships and other vessels.*—
[Sealed 21st March, 1842.]

THE oakum operated on by the patentee is composed either of new hemp, hemp-tow, or other suitable fibrous substances, or of old or second-hand ropes or rope-yarns, picked in the ordinary manner.

The new oakum is first acted on by a breaker or breaking-machine, if the fibres are too long, to reduce them to suitable lengths for passing through a carding-machine without clogging; it is then passed through an ordinary carding-machine, to equalize and straighten the fibres, and deliver it in continuous bands or slivers of sufficient thickness for caulking. The bands or slivers, thus produced, are now to be tarred, which is effected by forming them into a stout strand or haul of yarn (of such thickness as to pass properly through a rope-nipper to be tarred), and passing it through tar, or a mixture of tar and tallow, tar and oil, or other suitable ingredients, kept at a boiling heat. After this, the strand is separated into the original slivers, which are hung up to dry; and, while drying, the fibres of the slivers may be opened, or pulled apart a little, in order to increase their bulk, and prevent them from adhering too closely together previously to being used.

Old or second-hand oakum is to be made into slivers of uniform size and substance by the above method ; but as it has been previously tarred, the processes of tarring and drying, above described, are unnecessary.

The patentee claims the preparing of oakum, whether from new hemp or tow, or from old or second-hand stuff (as from ordinary picked oakum), or any other suitable fibrous substances, to be used for caulking ships or vessels, by passing it through suitable machines, and thus forming it into even and soft rovings, or slivers of suitable dimensions, and of uniform size and substance throughout their length ; and if made of new fibrous substances, which have never been tarred before, then he further claims the application of the tarring and opening process to such substances, and for such purpose as aforesaid ; by which mode of preparing oakum, he is enabled to prevent the inequality of substance now prevailing in the strands of oakum, twisted up by hand-rolling on the thigh and knee of the caulker, to save much time in caulking, and to secure a more perfect and even filling of the seam to be caulked.—
[*Inrolled in the Inrolment Office, September, 1842.*]

Scientific Adjudication.

INFRINGEMENT OF REGISTRATIONS.

(The following decisions from the Daily Press are given, to shew the City method of dealing justice in cases of infringement.)

GUILDHALL.

Before Aldermen Farebrother & Hughes.—October 1st, 1844.

WELCH & MARGETSON v. MAY.

MR. MAY, a hosier in Moorgate-street, was summoned to answer an information filed at the instance of Messrs. Welch and Margetson, of 134, Cheapside, haberdashers, for selling a fraudulent imitation of a part of a registered design for a shirt collar, novel in part of the shape thereof, without the license or consent of the registered proprietors, Messrs. Welch and Co.

Mr. Webster attended to support the information, and Mr. Lott, a solicitor, appeared for the defendant.

Mr. Webster stated that his clients were the proprietors of a registered design for an improved linen shirt collar. The improvement consisted in a new shape given to the two parts of

which collars were made. In the old collar a band was cut out straight, and the upper part curved. In the improved collar the band was curved, and the upper piece was straight, and terminated at the whiskers, instead of being continued round to the back of the neck. Mr. May, putting the registered article in his window, attracted many persons to his shop, but when they were within he shewed them what he called an improvement of the registered article, to the prejudice of Messrs. Welch and Margetson. What was called an improvement was a continuation of the upper part of the collar round to the poll of the neck, instead of terminating at the ear. It was merely a fraudulent modification, for the purpose of evading the charge of piracy, but, as it included all the advantages of the copyright, the law would not allow such a subterfuge. In the imitation, the band was curved, and the upper parts were straight where they were sewed to the band, just as in the original design, and of course they fitted with the same comfort.

Mr. Alderman Hughes said, the question then was, whether the defendant had sold an article in which the registered design was wholly incorporated, though yet not a complete imitation.

Mr. Alderman Farebrother thought it was an odd thing that it was registered at all. It seemed too trivial a matter to be protected with a copyright, or for the magistrates to waste their time in examining.

Mr. Alderman Hughes said it was not the first case of the sort that had been brought under his notice. The mere shape of a frill with flowers interspersed had been made the subject of a register.

Mr. Alderman Farebrother said the whole thing was so silly that he doubted if it could be protected by the act. A man obtained a patent for making a shirt-collar fit a little higher, or lower, or closer; then the price of the article was to be kept up to his mark, and nobody could cut out a shirt-collar without the risk of infringing on his copyright. The object of the act was to secure reward to great skill and ingenuity.

Mr. Alderman Hughes said, that the moment he saw the new collar he saw it was an improvement on the old shape, and he should patronize it. He had no doubt it was a proper subject for registration. Many of the inhabitants of his ward were engaged in trade that required the constant protection of the law to their original patterns, and this had drawn his attention particularly to the subject. The registering of a design was sometimes worth £3,000. to the inventor. As many as 23,000 articles had been registered since the act came into operation, and it would be to little purpose that the registration might be effected for *7s. 6d.*, if a poor man could only defend his right by an action at law. He thought a summary interposition of the magistrates was the proper way to protect inventions.

Mr. Alderman Farebrother yielded to the opinion of his brother magistrate. It seemed difficult to decide where the improvement was so small.

The magistrates having consulted, decided that the imitation was an infringement of the registration, and fined the defendant £5.

November 5th.

WOLFERSTAN *v.* WARNER.

MESSRS. Warner and Sons, brass-founders, attended to answer an information charging the defendants with having sold a boiler-tap, to which the registered design, No. 190, of Thomas Wolferstan, of Salisbury, for a safety-boiler tap, had been applied without his consent.

Mr. Webster attended to support the complaint, and Mr. Clarkson defended Messrs. Warner.

The certificate of registration was put in.

Samuel Milne proved the purchase of a boiler-tap at Messrs. Warners' for £1. 2s. 9d. He produced it, as also a sectional drawing of it, and of the registered design. In principle, he said, they were alike. The plug in both was alike, and the other parts of the imitation were so near to the original, as to answer the same purpose. He had made the drawing twice the size of the article, for facility of comparison.

Mr. Clarkson objected, that no case had been made out. The drawing of the Wolferstan design could not be taken as evidence. The article itself should be produced, that the magistrates might compare them, and that it might be seen that Wolferstan had entitled himself to the benefit of the act by manufacturing them for use, and not publishing them without the mark of registration.

Mr. Webster said, the magistrates had before them the registered description and drawing, and that was the standard by which the imitation was to be tried. He was entitled to the protection of the registration if he did not manufacture a single article during the three years.

Sir G. Carroll confessed he should have been better able to judge, if the articles themselves had been placed before him for comparison.

Mr. Alderman Johnson expressed a similar opinion.

Mr. Webster said he could not be called upon to prove a negative. It was not for him to shew that no safety-boiler tap had been issued without the registration mark, by calling everybody to whom one had been sold, nor was he to produce in court a steam-engine or any thing else that might be registered. The registered description was all the law required.

Mr. Milne said, he made the drawing of Wolferstan's invention from Mr. Wolferstan's description, and not from one of the

articles. He had since had one of the Wolferstan taps in his hand, and found it answered to his drawing. This was two days ago.

Mr. Clarkson urged, that it was very suspicious that Mr. Wolferstan did not produce one of his taps, that the magistrates might see whether Warner's was an imitation. The drawing they had of it was not even made from the article itself, but from Wolferstan's description.

The magistrates seemed to be about to decide against the complaint, when a Wolferstan cock was produced for the magistrates to compare with the imitation purchased by Mr. Milne.

Mr. Clarkson begged the magistrates to remark, that the registered tap was carefully kept back till it was wrung from them by the apprehension of an adverse decision, and he proceeded to shew, that the article produced as Wolferstan's was unlike, in some portions, the registered design. He insisted that the act did not include inventions of this class, and that Mr. Wolferstan, by endeavouring to evade the expense of taking out a patent at an expense of as many pounds as he had paid shillings for the registration, had overreached himself. The part for which registration was obtained was a mechanical contrivance, and not a mere change of form or configuration, to which alone the act applied.

The magistrates conferred for some time; and then,

Sir G. Carroll said, they did not think the case was proved.

Mr. Webster asked in what respect?

Sir G. Carroll declined going further into the question.

[As in law, *precedent* is the hinge upon which judgments most frequently turn, we would recommend to the notice of the city authorities the decision of the sage Wouter Van Twiller, that, when in doubt on any future occasion, they may take the registered article in one hand and the counterfeit in the other, and thus ascertaining the comparative weight of the designs, come to a safe conclusion, that, if one is heavier than the other, they cannot be alike.]

INSTITUTION OF CIVIL ENGINEERS.

TELFORD AND WALKER PREMIUMS.

1844.

THE Council of the Institution of Civil Engineers have awarded the following Telford and Walker Premiums:—

A Telford Medal in silver to William Fairbairn, M. Inst. C.E., for his paper "On the properties of the Iron Ores of Samakoff (Turkey), &c."

- A Telford Medal in silver to John Murray, M. Inst. C.E., for his "Description and Drawing of the removal of the Lighthouse on the North Pier, at Sunderland."
- A Telford Medal in silver to James Bremner, M. Inst. C.E., for his papers "On Pulteney Town Harbour," "Sarclet Harbour," "A new Piling Engine," and "An Apparatus for floating large stones for Harbour Works."
- A Telford Medal in silver to Andrew Murray, Assoc. Inst. C.E., for his paper "On the construction and proper proportions of Steam Boilers."
- A Telford Medal in silver to Alexander Angus Croll, Assoc. Inst. C.E., for his paper "On the purification of Coal Gas, &c."
- A Telford Medal in silver to James Braidwood, Assoc. Inst. C.E., for his paper and drawings descriptive of "The means of rendering large supplies of Water available in cases of Fire, &c."
- A Telford Medal in silver to Jacob Samuda, Assoc. Inst. C.E., for his "Account of the Atmospheric Railway."
- A Telford Medal in silver to Charles Hutton Gregory, Grad. Inst. C.E., for his paper "On Railway Cuttings and Embankments."
- A Telford Medal in silver to Captain William Scarth Moorsom, Assoc. Inst. C.E., for his "Description and Drawings of the Avon Bridge, at Tewkesbury."
- A Telford Medal in silver to Thomas Grissell, Assoc. Inst. C.E., for his "Description and Model of the Scaffolding used in erecting the Nelson Column."
- A Telford Medal in silver to Charles Manby, Secretary and Assoc. Inst. C.E., for the translation and arrangement of the "History of the Canal and Sluices of Katwyk," and the "Description of the Works of the Amsterdam and Rotterdam Railway," by the Chevalier Conrad, M. Inst. C.E.
- A Walker Premium, "The Transactions of the Institution of Civil Engineers," suitably bound and inscribed, to the Chevalier Conrad, M. Inst. C.E., for his "Description and Drawings of the Works of the Amsterdam and Rotterdam Railway."
- A Walker Premium of books, suitably bound and inscribed, to James Leslie, M. Inst. C.E., for his "Description and Drawings of the Iron Lock Gates of the Montrose Docks."
- A Walker Premium of books, suitably bound and inscribed, to John Geale Thomson, Grad. Inst. C.E., for his "Description and Drawing of the Landslip in the Ashley Cutting, Great Western Railway."
- A Walker Premium of books, suitably bound and inscribed, to John Timperley, for his "Account of the building of the 'Wellington' Bridge, Leeds."

- A Walker Premium of books, suitably bound and inscribed, to George Willoughby Hemans, Grad. Inst. C.E., for his "Description and Drawing of a wrought-iron lattice Bridge on the Dublin and Drogheda Railway."
- A Walker Premium of books, suitably bound and inscribed, to William Evill, Grad. Inst. C.E., for his "Description and Drawings of the London Terminus of the Eastern Counties' Railway."
- A Walker Premium of books, suitably bound and inscribed, to Arthur John Dodson, Assoc. Inst. C.E., for his "Description and Drawings of the Hydraulic Traversing Frame, used on the Great Western Railway."
- A Walker Premium, "The Transactions of the Institution of Civil Engineers," suitably bound and inscribed, to James Forrest, Jun., for his "Drawings and Diagrams illustrative of numerous Papers read at the Meetings."

THE following is a list of the subjects for which Telford and Walker Premiums are now offered by the above Society.

1. On the Theory of Arches, Abutments, and Piers, comparing the hypotheses of different writers; with practical examples of the application of the theory.
2. The history of the invention of, and improvements in, oblique Arches, with the theory and the practical methods of setting them out.
3. Experiments on the pressure upon every part of an oblique Arch, especially how the pressure varies as the angles become oblique.
4. On the construction of Retaining and Wharf Walls, with examples of failure and the causes.
5. A description of the Canal of the Helder (Holland), or of any foreign engineering works of a similar kind and importance.
6. The modes of Irrigation in use in Northern Italy; or Drainage adopted in the Lowlands of the United Kingdom; or works of a similar nature in Holland or in other countries.
7. On any of the principal Rivers of the United Kingdom (the Shannon), or of Foreign Countries (the Po, Italy), describing their physical characteristics, and the Engineering works upon them.
8. An account of the waste or increase of the Land on any part of the coast of Great Britain, the nature of the Soil, the direction of the Tides, Currents, Rivers, Estuaries, &c., with the means adopted for retarding or preventing the waste of the land.
9. The principles and practice of constructing Cofferdams.

10. The best and most economical mode of raising large Stones or Rocks from the beds of Rivers or Harbours.
11. The application of Gunpowder as an instrument of engineering operations.
12. The conveyance of Fluids in Pipes, under pressure, and the circumstances which usually affect the velocity of their currents; with accounts of Water Works and Gas Works.
13. The most advantageous method of employing the power of a Stream of Water, where the height of the fall is greater than can be applied to Water Wheels of the usual construction.
14. Experiments on Water Wheels, Steam Engines, and other machines, with the friction brake.
15. The construction of Cranes for raising and lowering weights.
16. The proportions of large Chimneys, as affecting their draught; with examples and drawings of the construction.
17. The drainage of Mines, exemplified by a statement of the actual condition of some of the Coal-fields or Mining Districts of Great Britain.
18. The ventilation of Coal Pits or Mines in Great Britain or in Foreign Countries.
19. The construction of Spiral and Fan-blowing Machines, and the power required to drive them, in relation to the pressure and volume of air delivered.
20. The smelting and manufacture of Metals in Great Britain or in Foreign Countries.
21. The comparative advantages of Iron and Wood, or of both materials combined, as employed in the construction of Steam Vessels; with drawings and descriptions.
22. The sizes of Steam Vessels of all classes, whether River or Sea-going, in comparison with their Engine Power; giving the principal dimensions of the Engines and Vessels, draught of water, tonnage, speed, consumption of fuel, &c.
23. The best forms for River and Sea-going Steam Vessels; with practical examples.
24. The various modes of propelling Vessels in actual or past use, and their comparative merits.
25. The results of the use of tubular Boilers, and of Steam at an increased pressure, for Marine Engines.
26. On the best application of the principle of Expansion to the improvement of the Steam Engine; with examples of the effect of such application, from actual experiment, and a description of the Engines experimented upon.
27. On the term "Horse Power," as applied to Steam Engines.

28. Description of Pyrometers, for ascertaining the degrees and the fluctuations of the temperature of the Flues of Furnaces, &c.
29. The various modes adopted for moving Earth in Railway Tunnels, Cuttings, or Embankments, with the cost thereof.
30. The proper slopes for Cuttings and Embankments in various soils.
31. Notice of the principal Self-acting Tools employed in the manufacture of Engines and Machines, and the effect of their introduction.
32. On the most effective and best adapted Machines for bruising or crushing the Sugar Cane, and for separating the juice from the vegetable fibre.
33. Memoirs and accounts of the Works and Inventions of any of the following Engineers :—Sir Hugh Middleton ; Arthur Woolf ; Jonathan Hornblower ; Richard Trevithick ; William Murdoch (of Soho) ; and Alexander Nimmo.

Original Papers, Reports, or Designs, of these or other eminent individuals, are peculiarly valuable for the Library of the Institution.

The Communications must be forwarded, on or before the 31st of May, 1845, to the Institution.

A METHOD OF ASCERTAINING THE QUANTITY OF CRYSTALLIZABLE SUGAR CONTAINED IN BEET-ROOT, OR OTHER SACCHARINE SUBSTANCES.

BY M. BARRESWIL.

THIS method is founded upon a peculiar property of sugar, noticed some years ago by M. Frommers, a German chemist. M. Frommers' method consisted in adding to the saccharine solution to be tested a few drops of sulphate of copper, and afterwards of potash, and heating the mixture to nearly a boiling temperature; the uncrystallizable sugar, or molasses, contained in the liquor reduces the salt of copper, and precipitates a red oxide of copper, while the crystallizable sugar contained in the cane does not change the properties of that salt.

M. Barreswil has turned to advantage this reaction, which was well known to chemists, and employed by them as a test of quality for determining the relative quantities of crystallizable sugar and molasses, when these substances are found either

alone, or in combination with other matters, in a solid body like raw sugar, or in a liquid, such as beet-root juice and cane juice. This process is founded on the following facts:— 1st. That crystallizable sugar does not reduce the oxide of copper contained in an alkaline liquid. 2nd. That it will reduce this oxide, when treated with sulphuric acid, which, on boiling for a few minutes, converts it entirely into uncrystallizable sugar or molasses. 3rd. That the quantity of deut-oxide which is reduced is proportionate to the quantity of sugar employed. We will, in a few words, describe M. Barreswil's process:—

If it be required to find the quantity of crystallizable sugar contained in a liquid, exclusive of other organic products, an alkaline solution of oxide of copper is to be prepared, by mixing sulphate of copper, neutral tartrate of potash, and caustic potash. A liquor of a deep blue color is thus obtained, which, on being filtered, remains clear and limpid for a long time. This solution is the *test liquor*, the power of which is to be determined by trying how much liquor, made with a certain weight of pure and dry sugar-candy, and raised to a boiling temperature, will suffice, after the addition of a few drops of sulphuric acid, to decolor perfectly a given quantity of the testing liquor.

The power of the test liquor having been carefully ascertained, a given quantity is to be poured into a capsule of porcelain or glass, and a suitable quantity of highly concentrated caustic potash is to be added. The only object of this is to augment the density of the liquid, and to facilitate the ultimate precipitation of the oxide of copper. Then, by means of a vessel with divisions marked thereon, the saccharine and acid liquor to be tested, is, after being diluted with a given quantity of water, poured, drop by drop, into the hot solution of oxide of copper. As soon as the two liquors come in contact, a yellow precipitate of hydrate of copper is formed, which becomes red, and falls to the bottom of the vessel, on reaching the temperature of the medium in which it was formed. As the operation proceeds, the color of the liquid becomes less deep, and at the same time the copper is precipitated in the form of protoxide; the operation is complete as soon as the liquid becomes completely colorless. Then, on reckoning upon the graduated vessel the number of divisions which have been employed for arriving at this result, the weight of the sugar contained in the liquor submitted to the experiment may be ascertained.

The essential and delicate part of the operation is to ascertain the exact time when the precipitation of the oxide of copper is complete: this is done by observing the time of decoloration of the liquor, if the saccharine liquor itself be colorless, and also by the cessation of the formation of the opaque yellow preci-

pitae which precedes the deposit of the oxide of copper. This latter will only be observed when the substance to be tested is colored.

An excess of sugar added to the test liquor, after the complete separation of the oxide of copper, gives the well-known brown color, resulting from the reaction of hydrated alkalies upon the uncrystallizable sugar.

If the saccharine liquor to be tested contains crystallizable sugar and molasses, the proportion of this latter substance is ascertained by making a previous experiment with a given portion of the liquid, before submitting it to the action of sulphuric acid; the molasses reduces the copper solution which the crystallizable sugar does not act upon. Another portion of the saccharine liquid is afterwards boiled with the sulphuric acid, so as to convert all the crystallizable sugar into molasses; by means of a second operation, with the liquor thus modified, the total weight of the molasses contained therein is ascertained; and, on deducting therefrom that of the molasses which it contained before (this having been furnished by the first operation) the difference will shew the quantity of crystallizable sugar contained in the mixture of water, ordinary sugar, and molasses.

M. Barreswil's process is distinguished, as will be seen, by great simplicity; it has been submitted by a committee of the chemical arts to strict trial; we have ascertained, that when a liquid contains only crystallizable sugar, its proportion may, in a quarter of an hour, be ascertained to the extent of two or three per cent. It may besides be ascertained, by previous experiment, if the liquor contains the least trace of molasses. When this latter substance is combined with the sugar, as is the case with cane or beet-root juice kept in the air for some time, or in fraudulent mixtures of brown sugar and granulated molasses, the operation is somewhat less correct.

Having shewn the advantages of M. Barreswil's method, we must now speak of its disadvantages. The principal one is, that it is only applicable to pure solutions of sugar, or a mixture of sugar with molasses. In fact, if the substance to be analyzed contains tartaric acid, dextrine, sugar of milk, &c., these substances act nearly in the same manner as crystallizable sugar, and might consequently be confounded with it; on the other hand, there exist, doubtless, some organic matters which have the effect of reducing the alkaline solution of oxide of copper, in the same manner as molasses; so that this process can only be employed with certainty when it shall have been proved by previous experiment, that no other organic matters exist in combination with the sugar or molasses, or that they have been separated therefrom by suitable means.

Notwithstanding these disadvantages, M. Barreswil's process is

capable of rendering great service to science and manufacture; but there is no doubt that it may be greatly improved by chemists who may make use of it. The committee have accordingly awarded to M. Barreswil a silver medal, and a sum of 1,000 francs out of the 3,000 francs which were offered to the inventor of a method more perfect, and of more general application. It is also decided that the question should be left open for further improvements until the meeting in 1845, and the reward reduced to 2,000 francs.—*Bulletin de la Société d'Encouragement.*

ON GILDING SILK FABRICS BY CHEMICAL MEANS.

BY M. LE DOCTEUR BRETTHAUER.

SOME years ago the Society for the Encouragement of Arts, at Berlin, offered a reward to any person who should succeed in gilding silken threads by chemical means, in such a manner that the gilding shall be solid (*i. e.* not liable to wear off easily), and the silk not only not deteriorated, as regards its wear, but in a fit state to be manufactured into woven fabrics, in the same manner as metallic wires.

Although the experiments which I, as well as others, have made for this purpose completely failed, as far as regards the gilding of silk in threads, I have nevertheless succeeded in obtaining, upon silken stuffs, as well as upon other fabrics, a coat of gilding more or less solid, which is more brilliant in proportion to the glossiness and fineness of the fabric before the operation. As I have yet operated only upon woven fabrics, principally satin, I do not pretend to have succeeded in performing the operation above proposed, and the more so as I have hitherto only operated on a small scale, that is to say, on surfaces a yard square; but, thinking a communication of the means I have employed, would serve to recall this subject to the minds of those who are interested therein, I have given the details of my first experiments, and the results thereof, which may have the effect of encouraging others to improve upon those means, which I have no doubt will, after many experiments, properly performed, end in complete success.

As regards the choice of the fabric to be gilt, the preference should be given to those of the most uniform texture and glossy appearance, for the reason above mentioned. My experiments

have hitherto been confined to satin, Gros de Naples, the finest linen fabrics, and lastly to paper, upon the gilding of which latter, I shall hereafter add some observations; but shall for the present confine myself to the process applicable to woven fabrics, dividing it into two parts: the first of which will treat of the dyeing of silk or other substances; and the second, of the manner of bringing out the golden or metallic lustre upon the surface of the fabric.

1.—DYEING OF THE SILK.

This operation is performed with an aqueous solution of chlorate of gold, which must not contain the least portion of free acid. A small quantity of free acid would not act directly in a destructive manner upon the silk, as it would upon linen fabrics; but it would be very injurious to the beauty of the gilding, as it seems to cause the gold to assume a purple hue, of which I shall treat presently.

A chlorate of gold, perfectly free from acid, is to be prepared in the following manner:—A quantity of gold (a ducat for example) is to be dissolved in *aqua regia*, which consists of a mixture of two parts of chlorhydric acid, and one part of nitric acid of commerce; the liquor is carefully decanted from the precipitated chlorate of silver, and evaporated to dryness at a gentle heat; the residuum is a chlorate of gold, containing no free acid. It is then to be dissolved again in pure water, and this solution is used for the dyeing process.

During this dissolution in water, especially when dried at too high a temperature, a solid body, consisting of metallic gold, is precipitated therefrom, which must be removed, in order to serve for a fresh operation. This separation of the metallic gold arises from the presence of a chlorate of gold, which, by means of the heat, is formed at the expense of the chloride, which loses a portion of its chlorine, and this chlorine, being again decomposed by water, forms a chloride with a deposit of metal. The chloride of gold, which is the highest degree of chloridation of the gold, is the one most fit to be employed for the operation in question.

The fabric is to be dyed in a hot solution, diluted with the necessary quantity of water. A cold liquor would not sufficiently penetrate the silk, and would adhere in too large a quantity to the surface, which would require to be expressed therefrom, and might therefore occasion loss. Besides, the salt of gold com-

bines but very imperfectly with the silk in a cold state, so that the gilding produced therefrom would rub off very easily; the liquor, therefore, only penetrates the silk uniformly at a boiling temperature.

A peculiar chemical phenomenon is here presented, which may be described in the following manner:—The silk, in fact, in this case, acts in the same manner as porous carbon. The peculiar properties of this body are well known, which are, to absorb not only different gases, and also a great quantity of coloring and other matters contained in liquids, but also to precipitate a sufficient quantity of salts from their aqueous solutions, and take them up; and as the silk acts in precisely the same manner, when it is in sufficient quantity, and has remained a sufficiently long time in contact with the boiling solution of gold, it absorbs all the gold and combines chemically therewith; so that the solution becomes colorless, and contains very slight traces of gold: a phenomenon which requires a more strict examination on the part of chemists.

In all my experiments, I have found a temperature of from 60° to 80° centigrade, to be sufficiently high for the dyeing liquor, only in that case the silk must be immersed a longer time therein. In this operation, it is better to raise the solution of gold to the boiling point, to plunge the whole fabric therein at once, let it boil there during a few seconds, and after taking it therefrom, wring or squeeze the liquor from it gently. The vessels employed must be of porcelain. The squeezing operation must be performed between plates of porcelain or glass, as these substances do not act injuriously upon, or absorb the salt of gold: neither metal, stone, nor wood, therefore, must be used for this purpose.

With regard to the degree of concentration of the solution, which serves as the dyeing liquor, this must be regulated according to the nature of the fabric to be dyed, as a weak solution only is required when a very close fabric is to be operated upon, whereas, if it is light, like satin for instance, it is necessary to use a stronger solution of salt of gold, in order to gild it properly. Before operating on a large scale, it will be necessary to determine, by experiment, the precise quantity of chloride of gold, or rather gold, which will be required to gild a certain quantity or a certain surface of fabric.

The silken fabric having been prepared, as above described, by being dyed in the chloride of gold, must be kept sufficiently

damp to allow of the operation of bringing out the golden lustre, *i. e.*, reducing the chloride to a metallic state. This operation might be performed, when in a dry state, by various means, such as sulphurous, phosphorus, or gallic acid, a solution of phosphorus, phosphoretted hydrogen, &c., and even by the simple action of the solar rays; but in these latter cases the gold would not possess much metallic lustre, and would have a brownish, bluish, or purplish hue; the silk dyed in chloride of gold assumes this color by simple dessication in the rays of the sun, or the light of day; silk possesses this property in common with other organic substances, such as feathers, &c. This purple coloring has been considered, by most chemists, to be a simple reduction of the chloride of gold: a supposition which is borne out by many facts. Under these circumstances the gold is seen in such minute particles, that it loses its metallic lustre, and assumes a reddish tint.

A great number of bodies, reduced to very thin or minute particles, assume a color very different to that which they present when seen in large quantities. I may mention, for instance, sulphate of copper, oxide of manganese, specular iron, sulphur in certain states, &c. Mercury, upon being reduced to minute particles, loses its metallic lustre, and assumes a greyish tint: many bodies, either in their natural state, or in chemical combination with other bodies, simply by a different molecular arrangement, assume different colors, as phosphorus, sulphate of mercury, &c.; and these various examples, and many others which might be cited, offer the presumption, that gold itself may, under certain circumstances, appear of a purple color. Besides, does not this metal assume this color when melted with porcelain enamel, in which case it is very minutely divided; and also as soon as the superficial and larger portions have been worn off by use?

This purple coloring of the gold upon the silk might be avoided, by plunging the fabric, before the dyeing process, into a solution which would neither effect the reduction of the chloride of gold nor render the fabric impervious to the solution of gold. I have found that the chloride of gold, upon a ground of resin or varnish, and also upon glass or porcelain, when reduced in a cold state, as hereafter described, does not assume a red color; I have consequently tried a very weak solution of resin in alcohol, or of caoutchouc in an essential oil, but I have not succeeded in obtaining satisfactory results.

2.—REDUCTION OF THE COLORING MATTER OR METALLIC DYE.

There are several methods of reducing the chloride of gold, and giving a metallic lustre to the surface of the silk. I shall only treat of one of these methods, as it is that which operates the most energetically and advantageously, and which, if the nature of the fabric to be gilt is taken into consideration, will probably produce the desired effect. This method consists in employing phosphohydric gas. The fabric, which had been previously dyed with the chloride of gold, is brought, in a damp state, into an atmosphere highly charged with this gas. During the operation the fabric must be kept damp, and the gas allowed to disengage itself freely. Although the fabric must not be dry, it should not be so wet as to allow the water to run therefrom, as the pellicle of gold would be carried away by the infiltration of the water, thus causing flaws and defects; the action of the gas must consequently be prolonged, as the operation takes effect first upon the surface of the fabric; and the coating of gold, thus formed, creates an obstacle to the action of the gas in the interior. The chloride of gold remaining in the fabric becomes ultimately, by the action of the light, of a purple or violet color, and thus injures the gilding. In order to avoid this, it is necessary, besides the phosphoretted hydrogen, which is present in sufficient quantity, to introduce steam into the chamber or box where the fabric is spread out in the manner most favorable to the operation, by which means the requisite degree of dampness is kept up.

Under the chamber is placed a vessel, of suitable size, with a large opening for the escape of the gas contained therein, and to prevent the introduction of any extraneous matters it may contain into the chamber; a plate of metal is placed at a short distance above the opening, and at one side of the chamber the necessary apparatus for injecting steam therein is fixed.

As soon as the disengagement of the gas commences, a slight metallic lustre appears upon the silk, which gradually augments until all the gold is brought out. If this development is moderated, metallic gold only is formed, as all the gas is decomposed, and phosphoric acid is formed, which remains in the fabric, together with the free chlorohydric acid. These acids may be afterwards neutralised, by means of damp ammoniacal vapours, although they do not injure the silk in the least degree.

If the action of the gas is more powerful, a brown phosphate of gold is easily formed, which, as long as there remains any chloride of gold undecomposed, acts as an agent for its reduction. But as soon as the chloride of gold has disappeared, there remains some phosphate of gold not reduced, which tarnishes the gilding. Even by employing heat, which must always be done after the operation, these portions remain in a lustreless state, although the phosphate of gold is decomposed at the temperature at which the operation of bringing out the lustre is effected.

Linen, woollen, and cotton fabrics, are operated upon in exactly the same manner as the silken one, only they must be purified from all extraneous matters, such as coloring matters, gums, &c.

Paper and card-board may also be very well and easily gilt. In the first place a deep ground color must be given to them, with a red oxide of iron, and a slight coating of varnish applied, and the surface (well dried) covered with a small layer of chloride of gold in solution. The paper or card-board is afterwards submitted to the action of phosphohydric gas, until the layer is completely reduced: it is afterwards polished with a burnisher of agate or steel.

I have succeeded in obtaining good silvered card-board, by employing a nitrous solution of silver, and operating in precisely the same manner. It is necessary to polish in this case also; and, consequently, this will not do for fabrics, which only take a slight metallic lustre. When the season is favorable, I shall try if these card-boards may be substituted for the expensive metallic plates of Daguerre.

I think that the details I have given will suffice to guide those who might be desirous of applying themselves practically to this process. It is unnecessary, I think, to describe the utensils required, as every person will know how to choose those which shall appear to be the most advantageous and convenient; and I shall conclude by some few observations upon the gas serving for the reduction of the solutions.

It is well known, that there exist two sorts of phosphoretted hydrogen, the one spontaneously inflammable in the atmosphere, and the other not. These two combinations may nevertheless be considered as modifications of the same gas, as the difference which it was imagined existed in their composition arose only from the impurity of the gases. It is very doubtful whether, for operations upon a large scale, it would be advantageous to em-

ploy the gas not spontaneously inflammable, as the preparation of the hypophosphorous or phosphorous acid requisite for the production of this gas is difficult and expensive. I think, therefore, that it is advisable to use the inflammable gas, notwithstanding the loss occasioned by the combustion thereof, as its preparation is much less expensive than the other. Besides, all the gas disengaged does not enter into a state of combustion, but only a small quantity, especially when it is rapidly formed; from which it would appear that the two gases are perhaps produced simultaneously. Besides, the inflammable gas burns at the surface of the liquid, where the bubbles burst and form phosphoric acid, which has, consequently, no hurtful effect upon the silk; and even if any portions of this inflammable gas rise as far as the silk, they are decomposed with such rapidity, by the chloride of gold, that no combustion can take place.

The mode of preparing this gas is very simple:—It is only necessary, for this purpose, to have a solution of caustic potash of sufficient strength, which is prepared, as is well known, with the ordinary carbonate of potash and quick-lime, and a small quantity of phosphorus. The phosphorus melts on heating it gently in the caustic lye, decomposes the water, and oxidizes by combining with the oxygen to form hypophosphorous and phosphorous acids, which combine with the potash. Another portion of the phosphorus enters into combination with the hydrogen of the water, and forms the phosphohydric gas required. A porcelain vessel, with a large mouth, is used for this purpose, and it is above this mouth or opening that a perforated metallic plate is placed, to prevent the effects of its too forcible entry.

The apparatus into which the gas is injected is not hermetically closed; there is therefore no fear of explosion.—*Bulletin du Musée de l'Industrie.*

ON COATING METALS WITH NICKEL AND PLATINA BY MEANS OF GALVANIC ELECTRICITY.

BY DR. BOETTGER.

THE application of galvanic electricity to various purposes in the arts, but more particularly to the purpose of coating ordinary

metals with the more precious metals, forms a subject of general interest.

This latter application in particular has, by the discoveries of the Messrs. Elkington and M. De Ruolz of a new class of salts, brought the coating of metals with gold, silver, and copper, to such a state of perfection, that it might be supposed there remained no further improvements to be effected in the employment of galvanism to this purpose. But it is evident that this is not the case, as no salt of nickel or platina has yet been discovered, perfectly adapted for depositing those metals upon common metals. It has, in fact, been found by experience, that a combination of cyanide of nickel with cyanide of potassium, according to M. De Ruolz's method, did not produce the desired effect, any more than the salt of platina, recommended by that gentleman for this purpose.

After many experiments I think I have discovered, and may state with certainty, that amongst all the known salts of nickel there is none better fitted for coating with nickel, especially upon copper and brass, than the *ammoniacal sulphate of protoxide of nickel*; at any rate it is superior, in all respects, to the double cyanide of nickel and potassium proposed by M. De Ruolz. Even when subjected, for a considerable time, to the action of the current, a plate of copper, when immersed in a solution of the ammoniacal sulphate of protoxide of nickel, will preserve its whiteness and brightness, which nearly equals that of silver.

I have succeeded, by operating during half an hour with a galvanic current of very little power, in depositing by this means upon copper, a coating of nickel of such a thickness, that an ordinary magnetized needle, suspended by a thread, was quickly flung from the plane of the magnetic meridian. A drop of common nitric acid dropped upon the layer of nickel did not produce, within a certain time, any visible effect upon the metal underneath, whilst a plate of copper, exposed during the same period of time to the action of the current in a solution of gold, is almost instantly attacked by the nitric acid; from which the conclusion may be drawn, that nickel precipitated by galvanism covers copper more quickly, closely, and uniformly than gold deposited by the same means.

Now, as it is well known that pure nickel is nearly as difficult of fusion as iridium and manganese, and that, with the exception of the gas blow-pipe, there is no fire, not even that of a porcelain

oven, which will fuse it, and also that it does not oxidize in the atmosphere, it will be conceived that practical persons ought not to view with indifference the preparation of this metal, so rare in a pure state, by galvanic means, if it were only for the purpose of manufacturing instruments where precision is required, such as magnetic needles, &c. A moderately powerful current must be used for this purpose, but acting in a uniform manner.

For the preparation of the above-mentioned salt the ordinary nickel of commerce may be used. It is to be dissolved in nitric acid, and a current of sulpho-hydric gas passed through the solution, during several minutes, to extract therefrom as much copper and arsenic as possible; the filtered solution is then precipitated by carbonate of soda, and when the carbonate of nickel has been well washed, it is dissolved in dilute sulphuric acid, and the whole is set to crystallize under a receiver with concentrated sulphuric acid. The solid crystals obtained are then pulverized, and placed in a bottle, and liquid ammonia poured thereon in small quantities, until it is completely dissolved. A liquor of a fine deep blue color is thus obtained, which may be immediately applied to the above-mentioned purpose.

With regard to the coating of copper and brass with platina, M. De Ruolz has proposed, as is well known, a solution of the chlorides of platina and potassium in caustic potash lye; but M. Petzhold, in a work which appeared a short time since, and in which he states that he has paid attention to this subject, says, that all the efforts he made to obtain, by M. De Ruolz's method, a good white coating of platina capable of resisting acids, met with no success. This statement of M. Petzhold, and also the failure of all my experiments, caused me to give more attention to this subject than it had hitherto received.

It will perhaps be remembered that I stated, some years ago, that copper and brass might be coated with a thin and perfectly white layer of platina, without the employment of a galvanic current, by boiling the metal to be coated (after it has been well cleansed) in water, in which one part of ammoniacal platina and eight parts of ordinary sal-ammoniac have been dissolved. Metallic articles, treated in this manner, become, in a few seconds, covered with a thick coating of white bright platina; it may, however, be as well to observe, that the coating of platina is never thick enough to resist the action of acids.

Upon endeavouring to precipitate a thick coating of platina from the same saline solution, by means of an electric current,

the operation is still more imperfect; the copper or brass articles, which are in contact with the negative pole, become, in a very short time, covered with a black substance, and a false color, arising from the precipitation of what is called *noir de platina*.

I have obtained a similar, although a better result, by employing a solution of chloride of platina and sodium, but I have not succeeded in this case in producing a coating of platina upon copper and brass, with a bright metallic lustre.

Solutions of other salts of platina had the same effect, with the exception of a solution, in water, of ammoniacal platina, prepared at a boiling temperature, to which a few drops of liquid ammonia are added, when the solution has cooled down to a moderate temperature. It is well known that chloride of ammonia and platina is not very soluble in water raised to a moderate temperature, but that it is much more so in boiling water. If, to a solution of this kind a few drops of liquid ammonia are added, when it has cooled a little, and afterwards, while yet warm, the solution is submitted to the action of a battery, acting uniformly and continuously, the platina will precipitate, in a very bright state, upon the copper surfaces in communication with the negative pole, and adhere very firmly thereto. This result, which I obtained more than eighteen months ago, and communicated to the chemical section at the annual meeting of German Naturalists and Doctors at Mayence, in 1842, has been partly confirmed by Professor Fehling. I say *partly*, because, according to the statement of that gentleman, no one has yet been able to obtain a coating of platina upon copper sufficiently thick to resist the action of boiling nitric acid. I may nevertheless assert, that I have succeeded, with this solution, in covering a capsule of copper, which was properly turned and polished in a lathe, with a pretty thick coating of bright platina; and after burnishing the first coating with a steel burnisher, and again submitting it to the action of the current, I obtained a capsule plated with platina, in which nitric acid, at the highest degree of concentration, might be boiled, for a considerable time, without any perceptible effect being produced thereby upon the copper underneath.

The only fault that can be found with the employment of this solution of platina is, that as it contains but a small quantity of metal, fresh liquor has to be frequently renewed, and exchanged for that which has become exhausted.—*Idem*.

ON THE DIFFERENT METHODS OF TRACTION OR PROPULSION ON RAILWAYS.

ATMOSPHERIC PRESSURE—TENSION OF A ROPE—HYDRAULIC—
LOCOMOTIVE ENGINES.

As propulsion on railways is a subject which has excited, and will continue to excite, much attention in the engineering world, the consideration of the various means now in use, as well as those proposed to be employed, to effect this object, cannot, we think, be otherwise than interesting to a large proportion of our readers. With this view we subjoin an article from a correspondent of the Mining Journal. The writer sets out by stating, that there are four general methods of traction practised on railways, where steam is the motive power, viz. :—

1. By means of a rope passing over and wound up by a drum, which revolves by the action of the engine.—2. By means of a tube extending the whole length of the railway, and containing a solid piston, which is forced along by the air being pumped out of the tube by an engine, stationed at one end of it.—3. By hydraulic pressure.—4. By means of a locomotive engine, which turns the wheels on which it rests, and by the friction of these with the rails carries the attached train forward.

Besides these four plans, a fifth, which has not been noticed by the writer of the article in question, has been proposed: we are not aware that it has ever had a fair trial upon a large scale, but we understand that some experiments with models have given results that have astonished many clever engineers. If we are correctly informed, the plan consists in mounting pairs of wheels, at convenient distances, along the whole length of a line of railway, and causing these wheels (by means of any convenient mechanical contrivance) to revolve with considerable rapidity. The carriage, containing the goods or passengers, is a mere sledge, and when required to be moved onward, it is lowered down, or otherwise brought on to the pairs of wheels before mentioned, which, by their rotation, propel the carriage forward. The pairs of wheels are arranged at such distances apart, as will always allow of the carriage being supported by two pairs. Proper means must, of course, be adopted for keeping the carriage upon the line. We understand that, by this plan, model carriages have been propelled up very steep inclines, with ascents

that could not have been surmounted by any of the ordinary means; but whether this can be effected upon a working scale, is a question that yet remains to be solved. The grand difficulty appears to us to lie with,—the means of actuating so many pairs of wheels—the expense of effecting this object—and the loss of power that must inevitably ensue. Not having had an opportunity of personally inspecting this plan of propulsion, we do not think it fair to enter into any further discussion of its merits, as we are not in a position to judge of how far the inventor has met or overcome the above objections, which most certainly are of great magnitude.

In each of these methods of traction or propulsion, a part of the power of the engine is lost in the transference.

The author enters upon the examination of the four plans of railway traction in the following manner: he says,

1. In traction by a rope, some part of the power will be absorbed by the friction of the rope with the road, or with the friction-wheels on which it is laid. Also, the parts of the rope between each two friction-wheels will hang down in a curve; force will be expended in raising and straightening these segments of the rope before the train can be put in motion. Moreover, if the rope possess elasticity, the engine must first stretch the rope to a certain extent before it can act on the train. It must be considered also that the engine starts not only the train itself, but also with equal rapidity a heavy rope, equal in length to twice the distance between the two railway stations. These causes would operate were the trains to move on rails perfectly even, but in practice obstacles occur at the joints of the rails and elsewhere, which communicate shocks to the train in motion. Hence will arise another abstraction of power; for at each shock the train will be slightly retarded, and then again accelerated, and consequently a vibrating motion will be given to the curvilinear segments of rope between the friction wheels. The vibrations arising from this and similar causes will be very observable in the line of rails parallel to that on which the train is in motion; the maintenance of these vibrations is a fruitless expenditure of power. An exact illustration exists in the endless bands used for communicating motion in steam weaving and steam printing, and even in common knife-grinders' machines; the most casual observer must have noticed the rapid vibrations of the bands in these cases. The motion of the tow-ropes of

river barges affords another example of those vibrations. From this cause, also, among others, steam-tugs tow vessels more efficiently when closely and rigidly lashed to their sides, than when connected by a long rope; and a garden-roller is moved over a rough gravel path more easily by pulling the handle than by pulling a long rope fastened to the handle. This last illustration suggests an experiment worth making, and easily made, by which the subject would be elucidated far more clearly than by written explanation. The alternate retardation and acceleration of the train will have another effect, which is due to the elasticity and weight of the rope; viz., that at each retardation the tension of the rope will be slightly increased, and at each acceleration diminished; the consequent stretching and un-stretching is maintained by force, which contributes nothing to the motion of the train.

2. In considering the application of steam power by atmospheric pressure, it will be necessary to remove a very common error, which supposes that power is in some way gained by the intervention of the air. Now, to refute this notion, it seems sufficient to state the general theorem, that "power is not gained, but only transferred by machinery;" or, taking the most favourable case that could possibly exist—viz., that the exhaustion of air should be perfect, and effected by apparatus air-tight, and without friction, it may be seen that whatever pressure exists on that end of the locomotive piston open to the air, can only arise from, and will be exactly equivalent to, the power exerted in removing a corresponding pressure from the other end of the piston, so that, even in this hypothetical case, power would not be gained, but merely transferred. But it will be shewn that, in practice, the amount of power actually transferred is much less than that expended. The causes of the loss are many; among them are the friction and leakage of the locomotive piston in traversing the whole length of the tube, and the friction and leakage of the air-pumps. But these are trivial compared with the enormous waste, owing to leakage in the fissure extending along the top of the tube; and this cause will operate after every precaution has been employed. The apparatus also for closing this fissure will require and abstract additional power, which contributes nothing to the motion of the train. There is another cause of power being lost, which, as I have never seen it noticed, I shall discuss at some length, viz.,

that arising from the elasticity of the air, and analogous to the effect already alluded to, of the elasticity of a rope, where that means of traction is employed. To determine more precisely the nature of the waste of force in atmospheric railways from the cause under consideration, we will imagine an atmospheric pressure of (suppose) 10 lbs. to the square inch on the locomotive piston necessary to overcome the inertia of the train, and set it in motion with the requisite velocity. "The elastic force of air at a constant temperature varies inversely as the space it occupies;" or, in other words, the pressure lessens in proportion as the air is rarefied, and increases in proportion as the air is condensed. Now, to produce a pressure of 10 lbs. to the square inch on one end of the moving piston, we must (taking the ordinary atmospheric pressure at 15 lbs.) diminish the elastic pressure in the tube of rarefied air till it amounts to only 5 lbs. on the square inch; that is, the air in a tube some three miles long, must be rarefied five-fifteenths, or one-third its original density, before the train can be put in motion. And the force requisite for this purpose contributes nothing, be it remembered, to the *subsequent motion* of the train, since, to maintain its motion, the pumps must continue to be worked exactly as if this preliminary exhaustion had not been effected, for otherwise the advance of the piston would soon condense the air again. It may be considered that we have over-estimated the loss of power in stating that "the preliminary exhaustion contributes nothing to the subsequent motion of the train." It may be argued that the amount of pressure necessary to merely put the train in motion is much less than that necessary to maintain its full velocity. In practice, however, the train is never started till a great proportion of the exhaustion has been effected, and before the train has performed but a very small part of its journey, the maximum exhaustion is effected. Moreover, up to that point the waste of power will continue to operate, though, of course, not in so great a degree as when the train is at rest, and diminishing as the velocity increases, for this reason, that, until the full speed is attained, the vacuum increases in degree, and is, therefore, carried on with greater rapidity than corresponds to the mere progression of the train. We must explain what is meant by "rapidity of exhaustion corresponding to the velocity of the train." When the rarefaction has reached that degree which is to be maintained without increase or diminution

throughout the journey, the train will also reach its full speed. It will follow, therefore, that, while the degree of rarefaction remains unaltered, for every foot which the motive piston advances along the air-tube, a quantity of air equal to that contained in one foot of the air-tube, will be pumped out by the engine. If this exact correspondence in the rate of pumping the air, and of the motion of the train, were not maintained, the degree of rarefaction would not remain unvaried. If the air were pumped out more slowly than the motion of the propelling piston required, the air would tend to condense, and *vice versa*. Of course, in this explanation the supposition of leakage is excluded. The elasticity of the air affords a reservoir of force, which, towards the end of the journey, would keep the train in motion for some little time after the air-pumps ceased to be worked. This circumstance might be considered another offset against our estimate, but that the train is never in practice allowed to come to rest gradually, but is stopped by the external force of breaks. On the whole, therefore, the amount of loss must be considered to be almost exactly that above estimated. The motive piston successively occupies every part of the air-tube, consequently, supposing no leakage, the air-pumps must, before the journey can be completed, pump out a volume of air equal to the solid content of the tube. Now, we have shown that, where the pressure is 10 lbs. to the inch, the extraction of two-thirds of this bulk of air contributes nothing to the motion of the train. We may, therefore, state, without appreciable error, that with the above degree of pressure the preliminary exhaustion wastes two-thirds of the power of the engine. The immediate corollary to this statement is, that the train is propelled most economically with a low degree of exhaustion of the air-tube. Supposing the pressure on the propeller to be only 1 lb., instead of 14 lbs. to the square inch, the waste would be but one-tenth of that estimated above; that is to say, one-fifteenth, instead of two-thirds of the power of the engine. It must be carefully noted, that the friction of the propelling piston is not an *immediate*, but an *ultimate* cause of loss of power. For any given diameter of the piston, the necessary degree of exhaustion increases as the resistance to the piston, from friction and other causes, increases. In other words, the amount of this waste is, in mathematical language, a function of two variables; that is, varies as the resistance to the piston and

length of the tube conjointly. So much for the waste of power from preliminary exhaustion. Before discussing the next cause of loss of power, we may consider parenthetically another method of propelling railway trains, which, as it has never, I believe, been carried into practice, is only introduced for the purpose of explanation and comparison with existing methods.

3. This third method of traction was based on two hydrostatic principles—that the pressure of water is directly proportional to its depth—and that the pressure is communicated equally in every direction. Hence, if a cistern containing water communicate by a tube of any form whatever with a piston fixed in the tube, the pressure will not depend on the quantity of water in the cistern and tube, but solely on the perpendicular altitude of the surface of the water in the cistern above the piston. In the case of the railway, the piston was attached to the train, and was to traverse a horizontal pipe laid along the whole length of the rails. The above law of liquid pressure is, however, laid down on the supposition that the fluid is at rest—when the fluid is *flowing*, the pressure is not by any means so great, and diminishes as the velocity increases, a great proportion of the force being absorbed by the mutual action of the fluid molecules, and their friction with the surface of the tube. Hence we come to another important truth, viz., that the laws of fluid pressure are by no means the same for fluids at rest and fluids in motion. This truth applies as well to the atmospheric as hydraulic railway. In the former, a large portion of the atmospheric pressure would be absorbed, and the labour of pumping increased, by the friction of the air with the inner surface of the tube; and this loss will not appear inconsiderable, when we recall some familiar instances of this kind of action. A trumpet is sounded, that is, the whole mass of metal composing it is thrown into a state of rapid vibration by the friction of air. The friction of air in the nozzle forms the greatest resistance to the working of the common bellows. A peg-top when spun is brought to rest principally by the action of air—not by resistance of the air in the ordinary acceptance of the phrase (for that would require projecting surfaces), but by the friction of it. A peg-top in vacuo has been known to continue spinning an hour and a half. If an inflated bladder have the mouth stopped, and only a small hole pricked in the side, it will take considerable force to drive out the air; the resistance is the friction of the air with the sides of

the hole. It is impracticable to light two distinct towns with gas from one gasometer, the gas being obstructed in flowing by its friction with the internal surface of the supply pipe. Excepting this friction of the tubes, the comparison between the hydraulic and atmospheric railways seems greatly in favour of the former. Water being incompressible (nearly so, at least), the loss corresponding to that from "preliminary exhaustion" is avoided in the hydraulic scheme; owing to water being much less subtle than air, the waste from leakage would also be much less. The hydraulic system affords also the convenience of a reservoir of power, for the power stored in the cistern may be employed at any distance of time after the cistern has been filled. The last effect of transmitting pressure by the intervention of air which we have to consider, may, like the preceding, be explained by analogy. In considering the rope traction, it was shewn that obstacles on the rails would cause a constant stretching and un-stretching of the rope, which would give rise to a waste of power. The reader will, on reflection, easily perceive that the same waste occurs in atmospheric traction, only proportionably increased, on account of the exceedingly greater elasticity of the material by which communication of power is effected.

4. In the fourth mode of traction, that by locomotive engines, the causes of loss of power differ altogether from the preceding: they arise from the power being employed in moving not only the train, but also the enormous additional weight of the engine and tender, which frequently amounts to fifteen tons; also from the occasional slipping of the wheels on the rails.

These, then, are the sources of the loss of force in the four methods of railway conveyance. In making, however, an election between them, many other questions besides that of loss of power would have to be taken into account,—such as the danger of breaking the rope, where that kind of traction was used; and, on the other hand, the fact that locomotive engines, by the very nature of their action, become inoperative on rails not nearly horizontal. With respect, however, to the mere question of waste of power, there will be no difficulty in determining, from the above considerations, the particular mode of traction in which the loss immeasurably preponderates.—“H. C. :” *Civil Engineer.*

LIST OF REGISTRATIONS EFFECTED UNDER THE ACT FOR PROTECTING NEW AND ORIGINAL DESIGNS FOR ARTICLES OF UTILITY.

- Oct. 30. *B. & J. Raworth*, of the Arundel Forge, Sheffield, for carriage-spring bearings.
31. *James Laurie*, of 11, Gracechurch-street, London, for an improved lamp burner.
- Nov. 1. *Job Allen*, of 20, Bower-street, Commercial-road, East, for an anti-explosive alarm whistle.
2. *Henry Brown*, of Solly Works, Sheffield, for a carpenter's improved brace-head.
2. *James Taylor*, of Great Grivendale, for a bridle bit.
5. *Joseph Wheeler*, of 92, Tottenham-court-road, for an improved pan for water-closets.
8. *Antoin Forrer*, of 136, Regent-street, London, for a card case.
8. *P. Howden*, of Penton-street, Pentonville, for a name and sign plate.
11. *Carpenter & Tildesley*, of Willenhall, Staffordshire, for an improved lock spindle.
12. *Alexander Dean*, of Birmingham, for a drum for thrashing and bolting corn.
12. *William Cooper*, of 20, St. Martin's-le-grand, for a multum-in-parvo seal.
12. *Joseph Fenn*, of Newgate-street, for a spring adjusting plane.
14. *Robert Bowman*, of Crane Foundry, Wolverhampton, for the "eubaron" or convenient weight.
14. *John Thompson Wilson*, of 1, Lower Vale Place, Hammersmith-road, Middlesex, for an improved smoke conductor.
15. *Joshua Pariente*, of 18, Coleman-street, for a strap or belt of attachment for articles of personal dress.
15. *Henry Hewetson*, of Cannon-street, city of London, for an improved revolving cinder sifter.
18. *Samuel Whitfield*, jun., of Oxford-street, Birmingham, for an improved rack pulley.
19. *James Grant*, of Vine-street, Westminster, for a design for increasing the illuminating power of lamps.

List of Patents

That have passed the Great Seal of IRELAND, to the 8th of November, 1844, inclusive.

To William Newton, of the Office for Patents, 66, Chancery-lane, in the county of Middlesex, engineer, for certain improvements in treating or preparing fatty or oily matters,—being a communication.—Sealed 21st October.

James Pillans Wilson, of Belmont, Vauxhall, in the county of Surrey, Gent., for improvements in treating and preparing fatty and oily matters, and in the manufacture of candles.—Sealed 21st October.

Peter Rothwell Jackson, of Strawberry Hill, near Manchester, in the county of Lancaster, engineer, for certain improvements in the construction of and manufacture of wheels, cylinders, hoops, and rollers, and in the machinery or apparatus connected therewith; and also improvements in steam valves.—Sealed 23rd October.

Francis Stanislas De Sussex, of Bethnal-green, in the county of Middlesex, chemist, and Alexander Robertson Arrott, of Torrington-square, in the same county, chemist, for improvements in the recovery of manganese used in making bleaching powder.—Sealed 23rd October.

William Basford, of Burslem, in the county of Stafford, brick and tile manufacturer, for certain improvements in the mode of manufacturing bricks, tiles, quarries, and other articles made or composed of clay or other plastic materials, and of burning and firing the same, and of certain other articles of pottery and earthenware.—Sealed 24th October.

William Cormack, of York-street, Cornwall-road, in the county of Middlesex, manufacturing chemist, for a new or improved method or plan for purifying coal gas.—Sealed 8th November.

List of Patents

Granted for SCOTLAND, subsequent to October 22nd, 1844.

To Josiah Davis, of Birmingham, engineer, for certain improvements in steam-engines, part of which improvements are applicable to impelling wheel carriages.—Sealed 26th October.

- Frederick Steiner, of Hyndburn Cottage, near Accrington, Turkey-red dyer, for a new coloring matter, to be used in dyeing certain colors on cotton, woollen, silk, and linen fabrics.—Sealed 30th October.
- Moses Poole, of London, for improvements in machinery for emptying privies and cesspools,—being a communication.—Sealed 30th October.
- Thomas Brown Jordan, of Cottage-road, Pimlico, mathematical divider, for improvements in the manufacture of blocks or surfaces for surface-printing, stamping, embossing, and moulding.—Sealed 11th November.
- George Ferguson Wilson, of Belmont, Vauxhall, Gent., George Gwynne, of Princes-street, Cavendish-square, London, Gent., and James Pillans Wilson, of Belmont, aforesaid, Gent., for improvements in treating fatty and oily matters, and in the manufacture of candles and night lights.—Sealed 11th November.
- James Pilbrow, of Tottenham, London, civil engineer, for certain improvements in propelling carriages on railways and common roads, and vessels on rivers and canals.—Sealed 13th November.
- Sir George Stewart Mackenzie, of Coul, Ross-shire, Bart., for an improvement or improvements in the manufacture of paper, more particularly for the purpose of writing and copying writings, and machinery for effecting the same; also the manufacture of a fluid or fluids to be used with the improved paper in the manner of ink.—Sealed 15th November.
- William Bodington, Jun., of Birmingham, manufacturer, for improvements in the construction of furnaces.—Sealed 18th November.
- John Dearman Dunnicliff, of Nottingham, lace manufacturer, William Crofts, of New Lenton, in the county of Nottingham, lace manufacturer, and John Woodhouse Bagley, of New Radford, mechanic, for certain improvements in the manufacture of lace and other weavings.—Sealed 18th November.
- Felix Moreau, of Ghent, engineer, for improvements in the manufacture of corks and other similar articles, made of cork, wood, or other materials, and the application of certain of the refuse matters to various useful purposes, for which they have never heretofore been employed.—Sealed 19th November.

John Groom, of Oldham, mechanic, for certain improvements in machinery or apparatus for preparing, slubbing, and roving cotton, wool, and other fibrous materials.—Sealed 22nd November.

New Patents

SEALED IN ENGLAND.

1844.

To George Fergusson Wilson, of Belmont, Vauxhall, Gent., George Gwynne, of Princes-street, Cavendish-square, Gent., and James Pillans Wilson, of Belmont aforesaid, Gent., for improvements in the manufacture of night lights. Sealed 29th October—6 months for enrolment.

Alexander Parkes, of Birmingham, artist, for improvements in the manufacture of certain alloys or combinations of metals, and in depositing certain metals. Sealed 29th October—6 months for enrolment.

George Robert D' Harcourt, of Old Jewry, Gent., for improvements in ascertaining and checking the number of checks or tickets which have been used and marked, applicable for railway offices and other places. Sealed 29th October—6 months for enrolment.

Thomas Squire, of Warrington, Lancashire, tanner, for improvements in tanning hides and skins. Sealed 29th October—6 months for enrolment.

Thomas Fuller, of Manchester, engineer, for certain improvements in machinery, tools, or apparatus for turning, boring, and cutting metals and other substances. Sealed 29th October—6 months for enrolment.

William Crofts, of Nottingham, lace manufacturer, and James Gibbons, of New Radford, machinist, for certain improvements in the manufacture of figured or ornamented lace or net of various textures. Sealed 31st October—6 months for enrolment.

George Fergusson Wilson, of Belmont, Vauxhall, Gent., George Gwynne, of Princes-street, Cavendish-square, Gent., and James

- Pillans Wilson, of Belmont aforesaid, Gent., for improvements in treating fatty and oily matters, and in the manufacture of candles. Sealed 31st October—6 months for enrolment.
- George Beadon, of Taunton, Somersetshire, Gent., for improvements in life boats or rafts, and in apparatus for raising or lowering the masts of vessels; which improvements in raising or lowering, are applicable to other purposes. Sealed 31st October—6 months for enrolment.
- William Newman, of Birmingham, brass-founder, for a certain improvement or certain improvements in window blinds.—Sealed 2nd November—6 months for enrolment.
- Charles Smith, of Newcastle-street, Strand, Gent., for new and improved methods in the construction and application of a variety of cooking, culinary, and domestic articles and utensils, some of which are applicable to cleaning, and a variety of similar useful purposes. Sealed 2nd November—6 months for enrolment.
- Jean Baptiste Maniquet, of the Sabloniere Hotel, Leicester-square, Gent., for improvements in doubling, twisting, and reeling silk, cotton, and other substances. Sealed 2nd November—6 months for enrolment.
- William Bewley, of Dublin, Gent., for improvements in fastenings for doors, windows, and other places where fastenings are used. Sealed 2nd November—6 months for enrolment.
- Thomas Brown Jordan, of Cottage-road, Pimlico, mathematical divider, for improvements in the manufacture of blocks or surfaces for surface printing, stamping, embossing, and moulding. Sealed 2nd November—6 months for enrolment.
- William Brunton, Jun., of Pool, near Truro, Cornwall, engineer, for improvements in apparatus for dressing ores. Sealed 2nd November—6 months for enrolment.
- Thomas Unsworth, of Derby, silk weaver, for an improved manufacture of elastic fabric. Sealed 2nd November—6 months for enrolment.
- Joseph Thomas, of Finch-lane, publisher, for a new and improved tube,—being a communication. Sealed 5th November—6 months for enrolment.
- Henry Atkins, of Nottingham, lace manufacturer, for certain improvements in the manufacture of net lace. Sealed 5th November—6 months for enrolment.

- John Groom, of Oldham, Lancashire, for certain improvements in machinery or apparatus for preparing, slubbing, and roving cotton, wool, and other fibrous substances. Sealed 7th November—6 months for enrolment.
- Stephen Geary, of Hamilton-place, New-road, architect and engineer, for certain improvements in the machinery, apparatus, and arrangements for the supply and distribution of water for public and private uses, but more particularly in cases of fire. Sealed 7th November—6 months for enrolment.
- Henry Borriskill Taylor, of Piccadilly, lamp manufacturer, for improvements in apparatus for transmitting light from lamp and other burners. Sealed 7th November—6 months for enrolment.
- Daniel Chandler Hewitt, of Hanover-street, Hanover-square, musical instrument maker, for improvements in certain stringed and wind musical instruments. Sealed 9th November—6 months for enrolment.
- David Auld, engineer, of Dalmarnoch Road, and Andrew Auld, engineer, of West-street, Tradestown, Glasgow, for an improved method or methods of regulating the pressure and generation of steam in steam boilers and generators. Sealed 9th November—6 months for enrolment.
- William Prosser, jun., of Windsor-terrace, Pimlico, Gent., for improvements in the construction of roads, and in carriages to run thereon. Sealed 9th November—6 months for enrolment.
- Richard Harris the elder, of Leicester, manufacturer, for improvements in machinery employed in the manufacture of looped fabrics. Sealed 9th November—6 months for enrolment.
- Charles Derosne, of Rue des Batailles, Chaillot, near Paris, Gent., for certain improvements in extracting sugar or syrups from cane juice and other substances containing sugar, and in refining sugar and syrups,—being an extension for the term of six years from the expiration of the term of the original letters patent. Sealed 9th November.
- John Dearman Dunnicliff, of Nottingham, lace manufacturer, William Crofts, of New Lenton, Nottingham, lace manufacturer, and John Woodhouse Bagley, of New Radford, mechanic, for certain improvements in the manufacture of lace and other weavings. Sealed 13th November—6 months for enrolment.

- Mark Freeman, of Sutton, in the county of Surrey, Esq., for improvements in working or dressing the surface of stone. Sealed 14th November—6 months for enrolment.
- Fredrick Steiner, of Hyndburn Cottage, Lancashire, Turkey-red dyer, for a new coloring matter to be used in dyeing certain colors on cotton, woollen, silk, and linen fabrics. Sealed 14th November—6 months for enrolment.
- William North, of Stangate, slater, for improvements in covering roofs and flats with slate. Sealed 14th November—6 months for enrolment.
- Isaac Farrell, of Great Brunswick-street, Dublin, architect, for certain improvements in machinery whereby carriages may be impelled on railways and tramways by means of stationary engines or other power, including certain apparatus connected with the carriages to run on same. Sealed 14th November—6 months for enrolment.
- Francis Watteen, of Finsbury-square, merchant, for improvements in preventing incrustation in steam boilers and steam generators. Sealed 16th November—6 months for enrolment.
- Joseph Maudslay, of Lambeth, engineer, for certain improvements in steam engines. Sealed 16th November—6 months for enrolment.
- Francis Higginson, of Rochester, Lieutenant in her Majesty's navy, and Edward Robert Coles, of Rochester aforesaid, merchant, for certain improvements in the construction of buildings generally. Sealed 21st November—6 months for enrolment.
- David Metcalf, of Leeds, dyer, for a mode of manufacturing or preparing a new vegetable preparation, applicable to dyeing blue and other colors. Sealed 21st November—6 months for enrolment.
- John Spencer, agent of the Phoenix Iron Works, West Bromwich, Staffordshire, for improvements in manufacturing or preparing plates of iron or other metal for roofing and other purposes to which the same may be applicable. Sealed 23rd November—6 months for enrolment.
-

CELESTIAL PHENOMENA FOR DECEMBER, 1844.

D. H. M.		D. H. M.	
1	Clock after the sun, 10m. 37s.	—	Jupiter R. A. 23h. 44m. dec. 3. 9. S.
—	☽ rises 10h. 26m. A.	—	Saturn R. A. 20h. 28m. dec. 19. 46. S.
—	☽ passes mer. 4h. 31m. M.	—	Georg. R.A. 0h. 9m. dec. 0.16. N.
—	☽ sets 11h. 31m. M.	—	Mercury passes mer. 1h. 31m.
	Occul. <i>C</i> Sextantis, im. 15h. 16m. em. 16h. 8m.	—	Venus passes mer. 21h. 25m.
2	Occul. <i>u</i> Leonis, im. 15h. 45m. em. 16h. 39m.	—	Mars passes mer. 20h. 42m.
3 2 8	☽ in ☐ or last quarter	—	Jupiter passes mer. 6h. 10m.
7 21	♃'s first sat. will em.	—	Saturn passes mer. 2h. 54m.
4 6 25	♃'s second sat. will em.	—	Georg. passes mer. 6h. 35m.
5	Clock after the sun, 9m. 0s.	15	Clock after the sun, 4m. 25s.
—	☽ rises 2h. 6m. M.	—	☽ rises 11h. 18m. M.
—	☽ passes mer. 7h. 37m. M.	—	☽ passes mer. 5h. 11m. A.
—	☽ sets 0h. 58m. A.	—	☽ sets 11h. 16m. A.
6 8 7	♄ in conj. with the ☽ diff. of dec. 3. 58. N.	16 3 22	☽ in ☐ or first quarter
18 5	♀ in conj. with the ☽ diff. of dec. 4. 40. N.	9 20	♃ in conj. with the ☽ diff. of dec. 6. 44. S.
7 12	♃ in conj. with Pallas, diff. of dec. 28. 54. S.		Occul. <i>m</i> Piscium, im. 6h. 23m.
9	☉ eclip. invisible at Greenwich	15 45	♃ in ☐ with the ☉
6	☽ in Perigee	21 55	♄ in conj. with the ☽ diff. of dec. 5. 46. S.
8 13	Ecliptic conj. or ☀ new moon	18 9 6	♃'s second sat. will im.
10	Clock after the sun, 6m. 48s.	19 5 42	♃'s first sat. will em.
—	☽ rises 8h. 27m. M.	20	Clock after the sun, 1m. 57s.
—	☽ passes mer. 0h. 36m. A.	—	☽ rises 1h. 11m. A.
—	☽ sets 4h. 46m. A.	—	☽ passes mer. 8h. 57m. A.
	♀ greatest hel. lat. N.	—	☽ sets 3h. 49m. M.
9 17	♃'s first sat. will em.	21 4 30	☉ enters Capricornus,—Winter commences
7 20	♄ in conj. with the ☽ diff. of dec. 4. 42. S.	22 13	☽ in Apogee
11 6 30	♃'s second sat. will im.	23	Occul. <i>ξ</i> Tauri, im. 9h. 10m. em. 10h. 17m.
8 12	♄ stationary	13 19	♄ in ☐ with the ☉
9 1	♃'s second sat. will em.	24 7 29	Ecliptic oppo. or ☉ full moon
12 12 44	♄ in conj. with the ☽ diff. of dec. 5. 25. S.	24	Occul. <i>γ</i> Geminorum, im. 9h. 6m. em. 10h. 25m.
19 35	♄ in conj. with Ceres, diff. of dec. 0. 34. N.	25	Clock before the sun, 0m. 33s.
13 10 40	♄ greatest hel. lat. N.	—	☽ rises 4h. 59m. A.
14	Mercury R. A. 18h. 36m. dec. 25. 28. S.	—	☽ passes mer. 0h. 9m. M.
—	Venus R. A. 14h. 57m. dec. 14. 46. S.	—	☽ sets 8h. 12m. M.
—	Mars R. A. 14h. 17m. dec. 12. 49. S.	14 25	Juno stationary
—	Vesta R. A. 21h. 45m. dec. 19. 13. S.	26 7 38	♃'s first sat. will em.
—	Juno R. A. 9h. 55m. dec. 0. 2. N.	8 26	Pallas in conj. with the ☉
—	Pallas R. A. 18h. 1m. dec. 3. 9. N.	18 5	♄ greatest elong. 19. 37. E.
—	Ceres R. A. 18h. 30m. dec. 26. 8. S.	27	Occul. <i>a</i> 1 Cancrī, im. 9h. 5m. em. 9h. 17m.
			Occul. <i>a</i> 2 Cancrī, im. 9h. 55m. em. 10h. 49m.
			Occul. <i>k</i> Cancrī, im. 16h. 15m. em. 17h. 28m.
		30 3 0	☉ in Perigee
			Occul. <i>e</i> Leonis, im. 15h. 49m. em. 17h. 3m.

J. LEWTHWAITE, Rotherhithe.

THE
LONDON JOURNAL
AND
REPERTORY
OF
Arts, Sciences, and Manufactures.

CONJOINED SERIES.

No. CLVII.

RECENT PATENTS.

To JOHN KEELY, the younger, of Nottingham, in the county of Nottingham, dyer, and ALEXANDER ALLIOTT, of Lenton, in the same county, bleacher, for an invention of certain improvements in machinery or apparatus for drying, or freeing from liquid or moisture, woollen, cotton, silk, and different fibrous materials, and other substances, and also for stretching certain fibrous materials,—being a communication.—[Sealed 2nd March, 1843.]

IN Plate XVI., fig. 1, represents, in partial sectional elevation, a machine for drying goods solely, or freeing them from liquid or moisture. A, A, is the framework of the machine; B, a vertical shaft, which turns in a socket *a*, in the bottom bridge *b*, and carries at top a friction-cone *c*, by which a rotary motion is given to it, in manner afterwards explained. *c*, is a drum, of two concentric compartments *d*, *e*, of the shape shewn in the drawing, which is fitted loosely on the shaft B, and rests, when not in motion, on two conical projections *f*, *g*, turned upon the shaft: both compartments have one common bottom of metal, and are formed at the sides each of a continuous length of tinned iron wire, wound in a

series of circles, at small distances apart, and connected transversely by slips of metal, soldered thereto. The top or cover of the inner compartment *d*, is secured by nuts and screws to a ring of angle-iron, which binds the wire sides together, at top; but that of the outer compartment *e*, in which alone the goods to be dried are placed, is made to lift off, in order to introduce and remove the goods, and has a rim, both on its outer and inner periphery; so that, when fixed in its place, the inner rim presses against the outside of the inner compartment, and the outer rim overlaps the sides of the outer compartment itself. When the machine is at work, the cover of the outer compartment is further secured in its place by bolts or pins (not seen in the drawing). The sides of the inner compartment *d*, are connected to the bottom by prolonging the transverse slips of metal which connect the circles of wire, and rivetting and soldering them to the plates. The wire sides of the outer compartment are bound together at top by a ring of angle-iron, to which they are rivetted and soldered, and are connected to the bottom plate by turning up the plate over the sides, and soldering and rivetting, as before. *d*, is a governor, suspended within the inner compartment *d*, of the drum *c*; the two weighted arms *h*, *h*, being loosely affixed at their elbows to two studs in the top plate of the drum, so as to turn freely thereon, and resting, by their upper ends, on a collar *i*, projecting from the shaft. *E*, is an outer case, which surrounds the whole of the drum, except at top, and is intended for the reception of the water driven off from the goods, but is fixed, not to the drum, but to the framework *A*, *A*. At *y*, there is a tap for drawing off the water, and in the bottom an orifice for the insertion of a pipe to admit hot air. When a rotary motion is given to the vertical shaft *B*, it carries round with it the drum; and, in proportion to the velocity of the motion, there is a centrifugal tendency imparted to the liquid particles contained in the goods (which is the useful effect desired to be produced by the machine); but, as the same centrifugal tendency in the parts of the machine would, in case of any unequal distribution of the weight, cause, if not counteracted, an injurious strain on the central shaft *B*, and might cause, at the high

velocities necessary for drying goods quickly, an actual disruption of the machine (and this difficulty is further increased when the weight of the goods happens to be not quite equally distributed over the drum), the governor *D*, has been introduced to prevent such consequences. The arms of the governor expand as the speed of the shaft increases, and gradually raise the drum *C*, from off its seat on the conical supports *f, g*; and thus the drum is left free to adjust itself according to its natural gravitating tendencies, so as to bring the centre of gravity in uniform coincidence with the centre of rotation. The drum is gimbed to the shaft in the manner shewn at *z*, fig. 1, which allows of its moving in any direction. To prevent the drum from rising too suddenly, there is a spiral spring *k*, affixed to the shaft, immediately above the conical support *g*. For still farther maintaining the drum in a state of equilibrium, it is encircled at the middle by a hollow ring or girdle *r*, which is about half filled with water, or other suitable fluid; as this ring rotates, should the weight of goods incline to preponderate at any part, the weight of water, getting to the opposite side, serves more or less to prevent and counteract such preponderance. The equilibrating effect of this ring is increased, if the interior is divided into two or more channels. *g*, is a pipe by which steam or hot air can be introduced into the centre of the drum, when it is desired by these means to accelerate the drying of the goods, the bottom of the drum being perforated at the centre with a number of holes, to admit the same. The rotary action of the shaft *B*, is obtained in the following manner:—*I*, is a disc, affixed to the end of a shaft, which disc is bevilled off near its periphery, to correspond, at that part, with the surface of the cone *c*, at the top of the shaft *B*, so that, when made to revolve in a horizontal direction, it shall cause the cone *c*, and shaft *B*, to revolve in a vertical direction. *L*¹, is a cone, affixed to the end of the shaft *K*¹; and *L*², another cone, of the same dimensions, but placed with its base opposite the apex of the other, and is affixed to a shaft *K*², communicating immediately with the first mover. *M*, is the belt which connects the two cones, and by the unwinding of which from the larger end of one cone upon

the smaller end of the other, or *vice versa*, with the help of a guide, in the known manner of working such alternate cones, motion is communicated to the shaft κ^1 , and is retarded, or accelerated, or kept at one constant rate, according as may be desired. n , is the pulley to which the power of the engine is directly applied. Instead of one friction disc only (l), being made use of, two such discs may be employed, if found needful, with an additional friction cone between them, the better to equalize the action of the rubbing parts; but in that case the additional disc and cone must turn loosely in their own bearings. Instead also of the vertical shaft b , being stepped at bottom, in the manner represented in fig. 1, the arrangement shewn in fig. 2, may be adopted. The bottom of the shaft is surrounded, immediately above the step, with a loose ring m , and that ring with a quantity of small shot, or other granulated substance, the whole being enclosed in a box n , the bottom of which forms the step. In the top of this box there is an opening, into which a collar p , on the shaft, dips, when the machine is at rest; and when the drum c , is raised by the action of the governor d , the collar is also raised out of its place, when the shot, yielding to the side-ward movement of the shaft, enables it to adjust itself to any change in the centre of gravity.

Another machine for stretching, and also for drying, is represented at figs. 3, and 4; fig. 3, being a side elevation, and fig. 4, a cross section of the machine. A, A , is the foundation plate. B , (see fig. 4,) is an axis, which turns in bearings in the front part of the standards c, c . The parts a^1, a^2, a^3 , are plain; the parts b, b , are a little raised above the others, and are cut, the one with a left-handed, and the other with a right-handed screw upon it. D, D , are a number of wire hoops, over which the cloth or other material is to be stretched, each consisting of four, five, or more rings of tinned iron wire, secured together by transverse slips of metal (similar to the wire sides of the drum before described), each of which is attached by radial arms to a separate collar, which slides on the smooth central part a^2 , of the axis B . The hoops, when brought together, have the appearance of one continuous drum, but are free to separate a little in the course of the

working of the machine. *E, E*, are two ventilators, of the form shewn separately at fig. 5; these ventilators are attached to moveable collars, with female screws inside, which work on the screwed parts *b, b*, of the axis *B*, and may be brought up more or less close to the series of hoops. On the rims *c, c*, of these ventilators there are rows of pins, to which the selvages of the cloth or other article to be stretched may be secured. In the centre of each ventilator an orifice is left, for the introduction, by means of a moveable pipe *F*, of a supply of steam or hot air into the interior of the hoops, round which the goods are stretched. *G, G*, are rings, of the form shewn on an enlarged scale at fig. 6, which, when the cloth or other article has been wound round the hoops, and secured to the pins on the peripheries of the ventilators, fit upon these peripheries, and interlock with and support the pins. It will now be seen, that if rotary motion is communicated to the axis *B*, and the drum is secured from turning by any convenient means, the ventilators will each have a tendency to move in an outward direction from each other, and thus cause a continued stretching of the goods laterally. To keep the goods at the degree of tension required, and prevent the ventilators from returning, there are two coupling pieces, each furnished on their inner surface with a small stud, which slides in a groove cut on each of the screwed parts *b, b*, of the shaft *B*, and having projecting sides, which take into corresponding recesses formed on the collars of the ventilators, are pushed forward. But, besides being stretched laterally, the goods may require to be stretched longitudinally, and for this purpose the machine is provided with the additional parts next to be described. *K¹, K², and K³*, are three cross rods or poles, fixed between the stops of the standards *c, c*, in a triangular position, as regards one another. *L¹, L²*, are two bars, which turn freely in bearings in the back of the standards *c, c*, and carry each two rollers, one at either end, which are connected by an endless band, armed with a number of small projecting teeth. *M*, is a roller, which turns on an axis between the standards *c, c*. *N, N*, are two longitudinal rods, which turn freely in bearings in the back of the

standards *c, c*, at one end, and in the shorter standards *o, o*, at the other end, and are cut with a thread upon them of a progressively decreasing pitch from *c, c*, towards *o, o*. *P, P*, are tubes, which slide on the rods *N, N*, having a catch *o*, projecting from the inside, which takes into the threads on these rods. *R, s*, are two additional rollers, which turn in bearings raised upon the top of the sliding tubes *P, P*, and are connected together at their ends by bands, in the manner shewn. The roller *R*, has a number of bristles affixed to it, for the purpose of brushing the goods as they pass in contact with it. The drum or cylinder of hoops *D*, before described, is connected with the roller *M*, by wheel-gearing, in the manner shewn in the drawings, and these again with the longitudinal shafts *N, N*, which carry the other rollers *R, s*, by means of bevil-wheel gearing. The distance between the roller *M*, and the rollers *R, s*, must be regulated at starting, according to the degree of stretching required to be given to the goods. To the roller *M*, a tacking-piece must be permanently fixed, to which the goods may be attached; this tacking-piece must be equal in length to a line carried from the bottom of the roller *M*, round the roller *s*, and back to the hoop-cylinder *D*.

The following is the operation of the entire machine:— The wheels being first thrown out of gear, by means of two small levers *l, l*, attached to the inner ends of the longitudinal rods *N, N*; one end of the goods is carried over the fixed poles κ^1 , κ^2 , and κ^3 , in the manner shewn, and thence down the face of the endless roller-bands L^1 , L^2 , the teeth of which catch into the selvages of the goods, and serve to keep them evenly distended in the direction of their width. The goods pass from the endless bands to the roller *M*, and are then joined to the tacking-piece on the roller, upon which they are then wound, by means of the winch-handle attached to its axis. The bevil-wheels are then put into gear again. The endless band-rollers L^1 , and L^2 , are brought into a horizontal position, the cloth unwound from the roller *M*, and carried under and over the roller *s*, whence it is carried back, in a direct line, to the drying cylinder of hoops *D*, and in its progress comes into contact with the brushes on the face of the cylinder *R*, and is again caught at

the selvages by the teeth of the endless bands L^1, L^2 . By turning the screw-threaded horizontal rods N, N , by means of the winch-handles at the ends, any required degree of tension may be given to the goods; for, according as these rods are turned in one direction or the other, the sliding-tubes P, P , are caused to recede or advance, and the rollers R, S , along with them. After the goods have been all wound on to the hooped cylinder D , the wheels are thrown out of gear, and the cylinder D , is made to revolve by itself. When hot air is used to assist the drying, and the goods are put into the machine in a damp state, the hot air should not be introduced till after the principal part of the moisture has been driven off by the centrifugal process. For the purpose of better maintaining the equilibrium of the machine, a ring or girdle T , containing water, or any other suitable fluid, similar to that before described, is introduced inside the hoops, in the manner shewn at fig. 4; the goods, being wound on the drum or cylinder D , are ready to be stretched laterally, as before described. The drum may then be disconnected from the intermediate wheel X , of the gearing, and a swift rotary motion being given to its axis, the liquid particles contained in the goods will be driven off by the centrifugal action, as before described under the first head of the improvements. Although the drum D , is shewn in the drawings in a horizontal position, it will be better, where drying is the chief object, to place it in an upright position, and then connect it with driving machinery, such as is described under the first head of the improvements. The outer cylinder, in which the drum is encased, and which should be some inches larger in diameter, has a pipe at the bottom, for the purpose of admitting steam, and another for the admission of heated air. It is further provided with a tap at bottom, for drawing off the liquid which collects there. After the greater part of the water has been thrown off, by the centrifugal action, a supply of steam is admitted, for the purpose of heating the goods previous to the admission of the heated air.

The patentees claim, Firstly,—the use of a drum or cylinder (*c*, fig. 1,) loosely connected with the driving shaft, as aforesaid; Secondly,—the combination of conical bearings,

f, g, with such drums; Thirdly,—the application thereto of a governor (*v*), deriving its action from the same centrifugal motion; Fourthly,—the ring or girdle *r*, fig. 1, containing the water or other fluid for the better preserving the equilibrium of the drum; Fifthly,—the driving of the machine by friction discs and cones, in manner before described; and Sixthly,—the formation of the drum, to the extent aforesaid, of tinned iron, or any other suitable sort of wire. And with respect to the stretching as well as drying of goods, they claim, Firstly,—the machine, in the general combination and arrangement of parts of which the same consists, whereby goods in a stretched state, or in the state of being stretched, are dried by the centrifugal action, in combination with the application of hot air; Secondly,—the use, for drying only, of the parts of the said machine applicable to that purpose; and Thirdly,—the use, for stretching only, of the parts thereof applicable thereto.—[*Inrolled in the Inrolment Office, September, 1843.*]

To ALFRED VINCENT NEWTON, *of the Office for Patents, 66, Chancery Lane, in the county of Middlesex, mechanical draftsman, for an invention of improvements in the manufacture of cyanogen and its compounds, particularly the prussiates of potash and soda,—being a communication.*
—[Scaled 13th December, 1843.]

THIS invention, as communicated to the patentee from abroad, consists in the application of nitrogen gas, which is obtained by the decomposition of atmospheric air, or from the waste gases of sulphuric acid chambers, to the manufacture of cyanogen, and the cyanides, by the processes and apparatus hereafter described. The operation, although simple in appearance, requires for its complete success several essential conditions, without which it is impossible to obtain an economical and regular result, such as is required for manufacturing purposes.

It is stated, that, by the means adopted by the inventor, the difficulties of carrying into practical and economical use

the grand principle of employing nitrogen, obtained from the surrounding atmosphere, have been surmounted.

The different materials which are employed in the process hereafter described, according to the peculiar circumstances of the case, are as follows:—First,—whatever may be the source from whence the nitrogen is obtained, it may always be employed, provided it is not accompanied by oxidating substances. It is not necessary that the nitrogen should be perfectly pure; it may be mixed with carbonic oxide, hydrogen, carburetted hydrogen, and other gases; but the presence of oxygen must be carefully avoided, as well as all matters capable of affording it, as they would tend to destroy the cyanogen as fast as it is formed. This essential point is effected and obtained, in an economical manner, by using atmospheric air, taking the precaution to convert the oxygen contained therein into carbonic oxide, before it is permitted to come in contact with the cyanides already formed. The means by which this is accomplished will be hereafter explained. Another source of nitrogen is the waste gases of sulphuric acid chambers, after being washed in a solution of sulphate of iron, and of milk of lime, so as to deprive them of sulphurous and nitrous vapour. The nitrogen so obtained is employed in the same manner as if obtained directly from atmospheric air, as hereafter described. Secondly,—the nature of the carbonaceous material, which is employed in the process, is not of much consequence; satisfactory results have been obtained with wood-charcoal, coke, pit-coal, peat, spent-bark, wood, and other similar substances; but, as regards economy, produce, and convenience, wood-charcoal, in pieces of the size of a hazel nut, is preferable to any other. Thirdly,—with respect to the potassa and soda, the carbonates are preferred; but any other salt capable of being resolved ultimately into carbonate, oxide, or metal, may be employed. Although the choice of the materials is not of much consequence, it is not so with regard to the mode in which they are employed: thus, the more or less intimate mixture of the charcoal with the alkali, and the proportions of the two, have a great influence. If the alkaline salt is easily fusible, it may be previously fritted with the charcoal, or the two substances may

be carefully mixed. It is, however, in general, preferable to soak or steep the charcoal in a concentrated alkaline solution, and to dry the mixture before using it; but whatever be the way of mixing the matters, it is of the greatest importance that they should be perfectly dry before they are placed in the retorts. The proportions of alkali and charcoal may be varied to a certain extent, but there are limits which should not be passed; an excess of alkali renders the chemical decompositions incomplete, and a too small proportion is not economical; but, according to the difference in the density of the charcoal, it may vary from 25 to 100 parts of alkaline salt to 100 parts of charcoal. With hard wood charcoal, the proportions which have been found to answer best are from 30 to 50 parts carbonate of potash to 100 parts of charcoal, according to the intensity of heat in the retort. As regards the quantity of nitrogen gas, it must be used in excess to hasten the operations; still, a too rapid current of gas must be avoided, because it would carry off with it a part of the cyanides already formed, and also a more or less proportion of unreduced alkali, and deposit them beyond the sphere of action. The combination of the nitrogen is effected most rapidly and completely when the gas is forced through a long column of alkalized charcoal, at a high degree of heat, and under a certain pressure, and when it experiences obstacles and considerable friction in penetrating through the pores of the charcoal and interstices between the pieces; all these conditions are combined in the most effective manner in the apparatus hereafter described.

After having considered these general questions, it remains to determine upon the most advantageous mode of constructing and working the apparatus. The points most worthy of attention are the following:—First,—heating the mixture of charcoal and alkali to the highest possible degree, and in the most uniform manner, and taking the proper precautions to recover the vapours of potassium, sodium, and other alkaline and saline combinations, that may be carried off with the waste gases. Secondly,—to force through the pores and interstices of the alkalized charcoal, a steady current of air, or nitrogen gas. Thirdly,—to protect the mass of cyanized carbon from all

contact with oxygen, during the whole period of heating and cooling. Fourthly,—A continuous operation, which is generally so advantageous in manufacturing processes, becomes here a necessity, or at least a most important consideration; because, setting aside the waste of fuel, labour, and time, the dilatations and contractions caused by interruptions of the work, occasion a speedy destruction of the apparatus; on this account, a perfect steadiness of firing and uninterrupted operations are peculiarly desirable.

The apparatus for carrying out these requisites may be varied in dimensions and form, and may be modified to suit different carbonaceous matters. It may be mounted either vertically or diagonally (caking coals, for instance, require a stirring apparatus, and the diagonal position is suitable for D retorts); but without confining the invention to the arrangement of parts herein set forth, two applications are described, which combine such practical and economical advantages as have been found by experience.

In Plate XVII., figs. 1, and 2, represent the simplest form of apparatus, in which one retort only is shewn. Fig. 1, is a vertical section, taken through the middle of the retort, and in the dotted line 1, 2, of fig. 2; and fig. 2, is a sectional plan view taken in the dotted line 3, 4, of fig. 1. A, A, represents the masonry of a furnace, of which the part *a, a*, is heated intensely, and as regularly as possible. B, B, is a retort, of fire-clay, or other suitable material, capable of supporting a white heat; it is open at the top *c*, and bottom *c*¹; its form may be elliptic, which is preferable to any other, and is best seen at fig. 2. The lower end *c*¹, of the retort stands upon, and is supported by, the flange of a second retort, or refrigerator D, D, made of cast-iron, and of a similar shape. At the bottom of this is adapted an extractor E, which is mounted on suitable bearings, and is worked periodically by an attendant, for the purpose of conveying the cyanized charcoal into the extinguisher or dip-pipe, the mouth of which plunges in the saline solution, which acts as a hydraulic valve, and closes the apparatus completely. F, F, is the waste gas-pipe, which conducts the gases and vapours into the hydraulic main G, G; the lower extremity of the

pipe *r*, is plunged into water, or into a solution of a salt of iron. *h*, is a pipe, by which the incondensable gases are drawn off by a pump or other convenient aspirating machine.

It is evident, that, in place of producing the current of gas through the apparatus by aspiration, the same purpose could be effected by forcing the air or gas through the mass; but the above described method of aspiration, or drawing, has been found more convenient.

Figs. 3, and 4, of the accompanying drawing, represent different views of an apparatus, consisting of ten retorts, working with one air-pump, and one hydraulic main, and with all the other suitable apparatus connected therewith. Fig. 3, is a vertical section, taken transversely through the apparatus; and fig. 4, is a horizontal section of the same. *i*, *i*, are pans or under-backs of iron, which receive the cyanized charcoal: they are kept constantly charged with a protosalt of iron, or with hydrate of protoxide of iron, diffused in the liquor, for the purpose of converting the simple cyanides into ferro-cyanides the moment they fall into the liquor. If thought desirable, a fire may be lighted beneath this pan, to warm the liquor, as shewn in fig. 3. *j*, *j*, are fire-places or furnaces for heating the retorts *b*, *b*. The conduct of the firing requires much attention; and, to prevent the slackening of the fire, and lessen the liability of the retorts cracking from variation of temperature, the magazine or hopper *j*¹, is always kept full of fuel: coke is preferred, as it gives a more intense and steady heat than bituminous coal. *k*, *k*, *k*, are the fire-flues. The form and dimensions of these parts of the apparatus may be varied according to circumstances. *m*, *m*, *m*, are horizontal flues, upon which the pans *p*, *p*, *p*, for drying the alkalyzed charcoal, are placed. The waste heat of the retort furnaces may likewise be applied to boil down the solutions of prussiates, and for many other purposes. *n*, *n*, are the ash-pits of the fire-places; *r*, is a vessel, (connected by means of a pipe *s*, to the hydraulic main,) for the purpose of receiving the condensed gases.

The working of the apparatus will be easily understood. The retort *b*, is kept constantly full of alkalyzed charcoal, and the air-pump *l*, fig. 4, (or other aspirating machine,) is

set to draw a steady current of air through the materials in the retort. The gas drawn through, as above mentioned, may be either burned air (consisting of nitrogen and carbonic oxide) or common atmospheric air, without any previous preparation, or hot air, as supplied to ordinary blast furnaces.

In both the apparatus above described, common atmospheric air is used, and the oxygen contained therein is converted into carbonic oxide by the upper layers of alkalized charcoal; but, as the charcoal is in excess, this causes no other inconvenience than a corresponding waste of charcoal. If it is considered worth while to save this waste, the atmospheric air may be previously passed through a mass of burning coal or coke, so as to deprive it of its oxygen before it is supplied to the alkalized charcoal.

It has been already mentioned, that the nitrogen gas must be used in excess, to hasten the operations. For an apparatus of the dimensions of that shewn in figs. 1, and 2, from 8 to 10 cubic feet per minute are drawn through. The firing being steady, and the current of gas regular, the retort may be supplied with a fixed quantity of alkalized charcoal in a given period. Both the feeding and extracting apparatus may be worked by machinery, if found convenient, as represented in fig. 3, where a long shaft *b*, extends the whole length of the apparatus, and carries pulleys *c*, which are driven by bands or straps *d, d*, passing over similar pulleys *e*, mounted on the axle of the extractor *E*. When it is required to make the feeding apparatus self-acting, a band or strap may be carried from pulleys on the long shaft *b, b*, over similar pulleys connected with the feeding apparatus.

The time required for reducing the alkali, and converting it into cyanide, is in the inverse ratio of the intensity of the heat; with a good white heat, two or three hours are sufficient to convert almost the whole of the alkali into cyanide. Whether the retorts are fed by machinery or otherwise, care must be taken to keep them constantly full, according to the working of the extractor, which, as before mentioned, delivers the cyanized charcoal into the dip-pipe, where it drops into the saline solution below; but, previous to this, it may be cooled in the iron retort, by surrounding a part of that vessel.

with a cold-water chamber *q*, as seen in fig. 3. The waste gases and vapours are drawn off by the air-pump *l*, fig. 4, through the pipes *r*, *r*, into the hydraulic main *g*, where the vapours are condensed. Each pipe is furnished with a stop-cock *f*, for the purpose of cutting off the communication, when required.

The liquor in the under-back should contain iron, either in the state of hydrate of protoxide, or in solution; which latter may be the nitrate, sulphate, muriate, &c., according to the potassa salt which may be preferred: to produce by double decomposition, there should always be a slight excess of iron or ferro-salts in the receiver, as, without this precaution, the simple alkaline cyanides are rapidly decomposed into formiates of potassa and soda, and carbonate of ammonia. The liquor in the under-back may be used either warm or cold. In the arrangement, represented in figs. 1, and 2, no method of warming is shewn; but in figs. 2, 3, and 4, the under-back is furnished with a fire-place for the purpose. It is easy to ascertain when sufficient iron is present: by taking out a small quantity of the clear liquor, and dropping into it a little weak solution of protosulphate, or any other proto-salt of iron, a white precipitate will fall without any tinge of red; but when, on the contrary, the liquor gives a brown red precipitate, or a mixture of red and white, it wants iron. When it is certain that the liquor contains a slight excess of iron, the charecoal is taken out and thrown into vats or cisterns, and washed, either with cold or warm water, until the salt is completely extracted; the weak liquors are passed successively through new charcoal, by which they are easily brought to 20° Beaumé's hydrometer. At this strength the liquors may be thrown into evaporating pans, and be boiled until the sulphate of potassa falls down; this is separated as usual, and drained. The remainder of the liquor is then drawn off into other vessels to crystallize; or, instead of drawing it off, the evaporation may be carried still further, until the prussiate also falls down and separates in a similar manner. The potassa mother liquors serve for fresh operations. The first rough crystals are washed and crystallized a second time, as usual.

The patentee claims the application of nitrogen gas, obtained from the atmosphere, or from the waste gases of sulphuric acid chambers, to the manufacture of cyanogen and its compounds, by causing it to pass through, between, or in intimate connection with a mass of incandescent carbon, mixed with such other materials as may be required; in whatever way, or by means of whatever arrangement of apparatus the application of the nitrogen gas to the said materials may be effected.—[*Inrolled in the Petty Bag Office, June, 1844.*]

Specification drawn by Messrs. Newton and Son.

To JAMES BREMNER, of Poulteney-Town, in the county of Caithness, civil engineer, for certain arrangements for constructing harbours, piers, and buildings in water, for cleansing harbours, and for raising sunken vessels.—
[Sealed 22nd May, 1844.]

THE first part of this invention relates to the construction of harbours, piers, and buildings in water, and consists in floating a wall or other structure to a distance, after building it near a quarry or other convenient spot, and then depositing it on the site where it is to remain. For this purpose, a vessel is constructed with compartments of two distinct kinds; one set being intended to contain the wall, and the other set to afford the buoyancy requisite for sustaining and floating the wall or other structure. The set of compartments for giving buoyancy to the vessel generally surround the compartments containing the wall; they may be of any convenient number and size; each is to be furnished with the means of letting in the water, when required, and at other times to be perfectly water-tight. The compartment containing the wall or other structure has a moveable bottom, called a slip bottom, upon which the wall is built, and which, during the building of the wall, and floating it to the proposed site, is sustained and kept close to the vessel by chains, passed around the vessel, and by screw-bolts, and caulked or rendered water-tight in the ordinary manner. The surface of the ground on which the structure is to rest having been carefully levelled

and prepared, the float is brought over the spot, and sunk by admitting water into the compartments ; the chains, or other means of retaining the slip bottom in its place, being then released, the wall is deposited on its permanent foundation, and the float rises immediately to the surface.

In Plate XVIII, fig. 1, is a transverse section of the vessel or float, with a wall built in it, exhibiting the plan of attaching the chains to the transverse beams, and the screw-bolts for the slip-bottom beam ends, which are to be unscrewed, and all the chains detached, as soon as the vessel is scuttled, and the wall set on the foundation ; fig. 2, is a transverse section, exhibiting both walls of a pier, finished with beams and chains, and hearting inserted ; fig. 3, shews the plan of securing any large harbour works, which cannot be finished in one season, against the winter storms, so that the works can be completely secured until the spring, when more lengths can be brought to it, and regularly bonded ; fig. 4, shews the plan of inserting longitudinal beams of timber into the walls, and also cross beams at various parts, as the work proceeds, the whole of which are bolted down, so as to form one solid mass ; fig. 5, is a transverse section of a vessel having three compartments for buoying out two walls, as represented ; and fig. 6, is a transverse section of the two walls, finished off, and hearted in, with the extra batter above low water.

The second improvement consists in the application of a vessel, constructed in compartments, as above described, for cleansing harbours, by conveying a large quantity of water to the place where its scouring effects are required, and confining it until low water, when it is suddenly discharged by releasing the slip bottom.

The third part of this invention consists in certain arrangements for driving the piles occasionally required in constructing buildings in water. Fig. 7, is a pile-engine, which drives three piles at once, the outside ones forming guides ; four small chains and anchors are shewn ; which may be laid out on any sand bank, at high water, or even in deep water, for guys. Fig. 8, shews the guys at the top of fifty-foot piles, as also stages for eight men and four winches, and the pile driven in the centre. Fig. 9, shews fig. 8, driven down

to the top of the centre pile, when another twenty-feet pile will be introduced, and driven down in the same manner. Fig. 10, shews the second centre pile driven down to the surface of sand or water, and the spars which were at first used as "sheer poles" are now "lashed to" with small chains, and then another length is "screwed-to" at the scarf, and the operation proceeds as before, and the piles may be driven to any depth, until sufficient hold of the solid bottom is obtained.

The last part of the invention consists in the application of the float or vessel, above described, to raising sunken ships or barges. The float is brought immediately over the ship or barge to be raised, so that the masts may come up through the centre compartment of the float (the slip bottom being removed), and chains are placed around the sunken ship, and made fast to the float.

The patentee says, "I do not claim, as of my invention, or the exclusive use of, any of the several parts or arrangements hereinbefore described and referred to, except when the same are employed for the purpose of my said invention, which I hereby declare to consist in the application of the arrangements, hereinbefore described, for the purpose of constructing buildings in water, or on sands, cleansing harbours, and raising sunken vessels."—[*Inrolled in the Rolls Chapel Office, November, 1844.*]

To GEORGE STRAKER, of the borough and county of Newcastle-upon-Tyne, ship-owner, for a certain improvement or certain improvements in ships' windlasses.—[Scaled 8th February, 1844.]

THE method heretofore adopted for working ships' windlasses has been by means of levers or handspikes, which fit into sockets or holes made for that purpose in various parts of the windlass; but such levers, or handspikes, having to be removed, at every portion of a turn of the windlass, into other sockets or holes, this method is attended with much labour and loss of time. In some cases, levers or handspikes have

been made to act upon a ratchet-wheel fixed upon the windlass, as well as upon a second motion-axle, on which is a pinion, working into a wheel in the windlass; but in these cases, as well as others now in use, whatever description of levers or handspikes is adopted, whether working direct from the windlass, or from a second motion-axle, as before described, great exertion of the body is required, and the action is slow, and not continuous; consequently, a long time is expended in weighing-up an anchor, and in many cases a great force of men, which at all times is not at command, is required. Now the nature of the present invention consists, in adapting to the ordinary windlasses now in use, after first removing the ends thereof, a second motion-axle, at any convenient height above the deck, with a pinion thereon, working into a wheel fixed upon the windlass at one side of the paul-bitt; and in fixing at each end of the second motion-axle a hand-wheel, or a series of spokes fitting into a nave or centre, of cast-iron or other suitable material; whereby the defects arising from the slowness and want of continuity of action, and deficiency of power, may be remedied. The hand-wheels or spokes, being of a convenient height above the deck, are easily turned by men stationed opposite the handles or ends of levers on the fore and aft part of each wheel, and may be kept constantly and uniformly in motion, and worked or turned with great rapidity.

In Plate XVI., fig. 1, represents a front elevation of a windlass, with the improvement applied; and fig. 2, is an end elevation of the same. *A*, represents an ordinary windlass, with both the ends cut off; *B*, is the second motion-axle, which may be placed at any convenient height, either fore or aft of the windlass; *C*, is a pinion upon the axle *B*, working into a wheel *D*, upon the windlass; *E*, and *F*, are the hand-wheels, or series of spokes, fitting into a nave or centre, of cast-iron or other suitable material, as before stated, and are fixed at each end of the axle *B*. The handles of these wheels may be made of any convenient length, and to take out of their sockets, when required, and from the centre: their number will depend upon the diameter of the wheels, and the power required. The wheels *E*, and *F*, may also be made in

the form of steering wheels, with an outer rim, and arms to the centre, and handles outside the rim. *G, G,* represent two winch-barrels on the end of the axle *B,* (beyond the hand-wheels) and *H,* and *I,* are two handles for working the same. In large ships, or where great power is required, such additional power may be obtained by having two other hand-wheels or series of spokes (such as above described, and marked *E**, and *F**, on the drawing), fixed in the place of the winch-handles *H,* and *I,* and may have a greater or less number of handles or spokes, as may be found most advantageous. The pinion *c,* is made to slide out of gear upon the axle *B,* at *x;* (there may be a wheel and pinion on each side of the paul-bitt, or other convenient situation, and the axle *B,* may be made in two pieces,) so that the winch or winches, as the case may be, can be used in warping the ship, or for loading or unloading the cargo, with or without the windlass, by means of a leading sheave for the rope to pass through the deck, by which timber can be taken in and discharged at the ports. The winches are intended to be worked by the handles *H,* and *I;* but when more power may be required, the hand-wheels or spokes *E**, and *F**, are intended to be used, which will be found of great advantage. In the windlass represented by the drawing, the wheel and pinion is in the proportion of 4 to 1, but these proportions may be varied as circumstances may require. The hand-wheels or spokes at the out end are seven feet in diameter, the spokes being eight in number, of oak, three and a half inches by two and a half inches at the socket. If at any time two men, at each of the hand-wheels *E,* and *F,* and two at each of the hand-wheels put on in the place of the winch-handles *H,* and *I,* could not heave the anchor, the ordinary hand spikes applied to the windlass can be used as an auxiliary, and additional men may be put to each wheel.

The patentee claims the application of the hand-wheels or spokes, before described, fixed upon the ends of the second motion-axle, when arranged in combination with a windlass.—
[*Inrolled in the Petty Bag Office, August, 1844.*]

Specification drawn by Messrs. Newton and Son.

To EDWARD COBBOLD, of *Melford, in the county of Suffolk, A.M., clerk, for improvements in the preparation of peat, rendering it applicable to several useful purposes, particularly for fuel.*—[Sealed 27th April, 1844.]

THE object of this invention is to deprive peat of the water which it contains, in a more expeditious and perfect manner than has heretofore been effected; this the patentee proposes to perform by beating the peat in water, so as to reduce it to a minute state of division, and then, by subsidence, and subsequent drying, to obtain the peat quite free from water.

The apparatus employed for this purpose is represented in Plate XVII. ; fig. 1, being a vertical section, and fig. 2, a plan view thereof. It consists of a bottom or base-plate *a*, encircled by a rim, of the height indicated by the dotted lines 1, 2; to this rim four uprights or standards *b, b*, are bolted, the upper ends of which are held in their proper positions by the ring *c*; and the space between the ring *c*, and the rim of the base-plate, is occupied by a sheet of wire-cloth *d*. In the centre of the apparatus is a vertical shaft *e*, carrying a frame *f*, to which the beaters *g, h*, are affixed; the shaft *e*, is caused to revolve, with the beaters, by turning the handle *i*, on the end of the horizontal shaft *j*, and thus communicating motion, through the mitre-wheel *l*, and pinion *m*, to the shaft *e*. *n*, is a pipe, through which a stream of water is constantly flowing into the apparatus.

When the machine is in action, a constant supply of peat is kept up, and the rotation of the beaters causes it to be broken up, and finely divided, so as to become intimately mixed with the water; the finer particles, being held in suspension by the water, are carried off by it through the wire-cloth *d*; and the coarser particles, which sink to the bottom of the apparatus, are run off, from time to time, through the door *o*; the particles thus obtained, when collected and dried, form a light fuel. The fluid portion, (consisting of the finer particles of peat and water,) after leaving the apparatus, is run into shallow reservoirs, formed in the earth, where the water being quickly absorbed, the deposited portions of peat

will harden into a compact substance, which, being cut into blocks, and dried, is suitable for being worked into various useful and ornamental articles, such as those which are now made of jet, ebony, or papier-mâché; it may also be used in the manufacture of artificial fuel, for cementing small coal together, so that it may be moulded into blocks of the required size.

In conclusion, the patentee says, "I do not confine myself to the apparatus shewn for carrying out my invention, so long as peat is beaten or broken up in water, agitated therein, and its grosser parts separated from the finer; and the apparatus for the performing such process may be varied, as regards its mechanical arrangements, so long as such beating, agitating, and separating, can be performed thereby. And I would wish it to be understood, that what I claim as my invention is, the mode of treating peat, as regards its application to several useful purposes, particularly for fuel, as I have hereinbefore described it."—[*Inrolled in the Inrolment Office, October, 1844.*]

To JOHN BAILEY DENTON, of Gray's Inn Square, in the county of Middlesex, land agent, for improvements in machinery for moulding or shaping clay, and other plastic substances, for draining and other purposes.—[Sealed 18th April, 1844.]

THIS invention of improvements in machinery for moulding or shaping clay, and other plastic substances, consists in a mode of using two screws, which press the clay either directly through suitable moulding orifices, or into a chamber or chambers, from which the clay is forced through suitable orifices by other apparatus.

In Plate XVII, fig. 1, is a front view, and fig. 2, a side view of the machine. It consists of a cast-iron box *a*, mounted on a carriage *b*, and divided, in the direction of its length, into two compartments, in each of which a piston *c*, works; motion being communicated to them from the crank-shaft *d*, by the rods *e, e*, connected to an arm *f*, descending from each piston-rod *g*; upon the end of the crank-shaft is a spur-wheel

h, gearing into a pinion on the same shaft as the fly-wheel *i*, (which is turned by manual labour, through the medium of the handle *j*, or by horse or other power,) and by this means the rotation of the crank-shaft is produced. Upon the top of the box *a*, is a square or circular cast-iron case *k*, containing a pair of screws (represented by dotted lines), placed vertically, or otherwise, and caused to revolve, in opposite directions, by the bevil-wheels *l*, and spur-wheels *m*. At the front of the box *a*, is bolted a moulding or die-plate *n*, having two orifices in it, suitably formed for producing tiles, pipes, bricks, and other articles.

The clay or other material (which is thrown into the hopper *o*, at the front of the case *k*,) is, by the continuous action of the screws, pugged or mixed, and pressed downwards into the case *a*, where it is acted upon by the pistons, and forced through the orifices in the moulding-plate *n*, on to the table *p*. When the required form is thus given to the clay, it is cut across into pieces of the desired length, by any suitable cutting apparatus.

If the moulding orifices were in a line with the axes of the screws, continuous pipes, tiles, or other articles, would be formed, and might then be cut into suitable lengths; but the patentee prefers that the combined action of the screws should be employed for continually filling a divided chamber, within which pistons work, as above explained.

He claims the mode of combining the action of two screws to force clay or other such material through moulding orifices, and into compartments, from which it is forced by other apparatus, as above described.—[*Inrolled in the Inrolment Office, October, 1844.*]

To ALFRED RICHARD JOHNSON, of the firms of Messrs. Johnson and Company, Regent-street, and Messrs. Griffiths and Johnson, Old Bond-street, in the county of Middlesex, hatters, for certain improvements in hats.—[Sealed 28th March, 1844.]

THESE improvements consist in rendering more pliable, elastic, and easy of wear, such hats as are now wholly or partly made

of silk, hair, hair-stuff, wool, cotton, linen, hemp, or any other materials feltable in themselves, or capable of being worked up with feltable materials, by the introduction of a sheet of India-rubber into the body of the same, in the following manner:—The foundation of the hat having been made in the ordinary way, a covering of linen or cotton is added, then a sheet of India-rubber, and over this a second covering of linen or cotton; the hat is then “roughed or plated,” and finished.

The patentee claims the making of hats, of the various sorts before described, with a layer of caoutchouc or India-rubber added to, or introduced into, the body of the same, in the manner before described.—[*Inrolled in the Inrolment Office, September, 1844.*]

To ROBERT HAZARD, of Clifton, near Bristol, confectioner, for improvements in baths.—[Scaled 30th May, 1844.]

THIS invention consists, firstly, in a portable shower-bath, similar in its object and use to the common nursery or hand bath; and secondly, in a new form of receiver or foot-pan, in which a person stands when using the bath.

The bath is shewn in Plate XVI., at fig. 1; and consists of a vessel *a*, the bottom of which is perforated with numerous holes, and in the top, at the centre, there is a hole, communicating with the passage of a swing joint, ball-and-socket joint, or other flexible joint, that connects the vessel *a*, with the rods *b*. One or both of these rods being hollow, a passage is formed for the air from the interior of the vessel to the handles of the rods, where there is a hole *c*, to be covered with the thumb, finger, or a spring-valve. Fig. 2, represents a similar bath, suspended for invalids or infirm persons, having a flexible air-pipe *d*, with a hole *c*, in the handle, to be covered as above described.

Fig. 3, is a vertical section of an improved portable receiver or footpan, open for use. *e*, is the receiver, in the centre of which is a raised platform or vessel *f*, for containing hot water, with a moveable cover, forming a feet-warmer, on which the

person stands ; the receiver is furnished with a funnel-shaped curtain *g*, of oil-cloth or other suitable material, to catch and collect the falling water ; it is fastened to a moveable ring *h*, and is distended by means of the rods *i*, which are jointed to the ring *h*, and have likewise a joint at *j*, to enable them to be folded down into the receiver, (as indicated by the dotted lines *k*, *l*,) when it is to be conveyed from one place to another. Fig. 4, is a larger receiver for domestic purposes, constructed with a dipping-well *m* : in consequence of the increased size of this receiver, the rods *i*, are not required to be jointed in the middle, as in fig. 3, in order that they may be folded into the receiver.

The mode of using the bath and foot-pan, or receiver, is as follows :—The folding curtain *g*, of the receiver having been distended, the person dips the perforated vessel *a*, into water, which, entering through the perforations in the bottom, soon fills it ; he now closes the air-hole *c*, in the handle, and, standing in the receiver, lifts the bath over his head ; the hole *c*, is then uncovered, and the air, rushing in, proceeds up the hollow rod *b*, and pressing upon the water in the vessel *a*, causes it to descend in a shower. The shower may be repeated, by dipping the bath into the well *m*, of the receiver, or (if it be made without a dipping-well) into any vessel containing water.

The patentee does not claim, as his invention, constructing baths, in which the water descends on the admission of air through a small aperture at or near the top. But he claims, Firstly, constructing such baths, when the connection between the vessel containing the water and the handles or points of suspension of the vessel is a swing or flexible joint, as above described ; and, Secondly, the peculiar construction of receiver, with the folding curtain and single or double-jointed rods, for enlarging the diameter, combined with the foot-warmer and dipping-well, as described.—[*Inrolled in the Inrolment Office, November, 1844.*]

To DONALD GRANT, of Greenwich, in the county of Kent, Esq., for improvements applicable to the ventilation of apartments in which gas and other combustible matters are consumed by ignition.—[Sealed 18th April, 1844.]

THIS invention consists in an improved mode of constructing and arranging certain apparatus in connection with gas or other burners, whereby the products of combustion may be carried off, and the apartments, in which such burners are situate, effectually ventilated; also, by means of these improvements, the apartment may be kept at a uniform temperature, or nearly so, as the heated and foul air, which rises to the upper part of the room, will be carried off by the improved apparatus, which will be found more particularly useful and advantageous when burners that give out considerable heat, and a large body of flame, are used, as is the case with most centre lights constructed on the Boccus or Bude principle, in which metallic tubes are employed to carry off the products of combustion. It has been found, that the gases and other products arising from the combustion of carburated hydrogen gas, act injuriously upon and destroy these metallic tubes, even when they are made of copper; metal is also so good a conductor of heat, that tubes made of this material are liable to get overheated, and would ignite any inflammable substance that might be contiguous thereto. The object of the present invention is to obviate these difficulties as much as possible; and to effect this object, the patentee employs pipes, made of earthenware or stone-ware, to conduct the products of combustion away from the burners. This material is not only a bad conductor of heat, but it may be heated to a very high temperature without danger; moreover, it is not liable to oxidation, or to be otherwise injuriously acted upon by the carbonic acid, or other gases, arising from the flame.

The burner is suspended from the ceiling, in the manner shewn in Plate XVIII., at fig. 1, which represents a pendent burner, with these improvements applied thereto, the ceiling of the room, and also the flooring of the room above, being shewn in section; fig. 2, is a sectional view of the ceiling and

flooring, taken in a line at right angles to the preceding figure, and shewing the plan of carrying off the products of combustion through tubes, suspended between the ceiling and flooring; fig. 3, is a transverse section of the earthen or stone-ware tube, (taken on the line *A, B*, of fig. 2,) together with its jacket or covering, and appurtenances, shewing also the mode of suspending the tubes. The burner is supplied with gas from the main pipe *m*, by means of the pendent pipes *r, r*; and it is represented, in fig. 1, as having an ordinary glass chimney *a*; it is also furnished with a series of conical glass chimneys *b, b, b*, ranged one above another, and supported by moveable galleries *c, c, c*, which may be set and maintained at any height on the pendent tubes *r, r*, by means of screws. The upper end of the ordinary glass chimney *a*, is inserted a short distance (about half an inch) into the lower end of the lowest conical chimney *b*, and the upper end of the latter is inserted in the lower end of the next, and so on; the upper end of the highest conical chimney being inserted into the opening in the earthen or stone-ware elbow tube *n*, in the ceiling, as seen best in fig. 2. By this means the products of combustion are effectually prevented from escaping into the room, and a constant draft of the heated and foul air is kept up into the interior parts of the chimneys *b*, at all the junctions, and also through a ventilator in the ceiling, into a chamber surrounding the pipe *n*, as will be hereafter described. The products of combustion pass from the earthen elbow tube *n*, along the long straight tube *d, d*, made of similar materials, and constructed in lengths of about two feet, luted together with any suitable cement. The tubes may be made of any convenient form, such as round, oval, square, or flat. The sections of the earthen tube are furnished with projections *e, e*, (see the detached views, figs. 4,) and the whole length of the tube is surrounded by an iron or other metal casing *f, f*, which is supported in slings *s, s*, attached to the joists, as seen in figs. 2, and 3; and the earthen tube is supported in the metal one, by the projections *e, e*, so that there is a free current of air all round the earthen tube. The casing *f*, also surrounds the elbow tube *n*, as shewn in the section, fig. 5. Fig. 6, is a plan of

the casing, shewing its position between the joists *o, o*, and the manner in which the cross-bars *u, u*, are placed, that support the casing, elbow tube, &c.

A metal ventilating-plate *g*, surrounds the aperture into which the upper end of the highest conical glass chimney is inserted, and is partly covered by a shield *v*, a plan view of which, as seen from below, is represented at fig. 7; the shield being secured to the chimney by the screws *w, w*. The ventilating plate is furnished with holes or apertures, whereby the hot and foul air from the apartment is admitted into the space between the metal tube *f, f*, and earthen tube *d, d*, and allowed to pass along this annular space, in the direction of the arrows, until it ultimately escapes, either into a flue, or into the external atmosphere, through the nozzle *h*. The products of combustion, being conducted along the earthen tube *d, d*, do not become mixed with the heated air from the apartment until both are upon the point of escaping into the atmosphere, through the nozzle *h*. In order further to insure against any of the parts becoming overheated by the heat arising from the flame of the burner, a cold-air pipe *i, i*, communicating with the external atmosphere, is made to convey a stream of cold air, and cause it to impinge against the outer surface of the metal tube or jacket *f, f*; and this current of cold air, being allowed to play freely all round the whole extent of the external surface of the metal tube, will carry off the superabundant heat therefrom, and keep the tube moderately cool. This current of air eventually escapes through the apertures *j, j*, in the vicinity of the before-mentioned aperture *h*. The cold-air tube *i, i*, may be made either of earthen or stone-ware, or of iron. It is represented as being suspended by slings *s, s*, in the same manner as the metal tube *f, f*, but it may be applied, affixed, or suspended, in any other convenient manner. The ceiling of the apartment in which the light is burning is seen at *k, k*, the flooring of the room above at *l, l*, and the gas supply pipe at *m*; and, as all the apparatus can be laid between two joists, as seen in fig. 3, it may be hidden from sight, and placed out of all danger of accidental injury, and it can be easily fitted or applied, by removing one or two of the flooring boards above.

As the heat given off from a burner of large size is very considerable, the patentee proposes to use this heat for the purpose of warming an adjoining apartment. One plan of effecting this object is shewn at fig. 8, which represents a vertical section of the apparatus. *b*, is the upper end of the highest conical glass chimney; and *d, d*, is the earthen or stone-ware tube, which carries off the products of combustion; but, instead of these products being carried off directly, as in the former case, they are conducted upwards, through the flooring *l, l*, of the room above, into an earthen or other vessel, chamber, or stove *t, t*, where they radiate their heat, and then pass down another earthen pipe *d*¹, into the horizontal pipe *d*², and finally escape into the atmosphere. *f, f*, is the metal jacket or covering, which surrounds the earthen pipe, as in the other instance; and *i*, is a cold-air pipe, bringing air from the external atmosphere, which, by circulating through the bent pipe *p, p*, becomes warmed by the products of combustion that issue from the pipe *d*; and when thus warmed, the air in the bent pipe *p*, is allowed to issue from the ventilator *q*, into the room above. The bent pipe *p, p*, is made flat or oval, as seen in the drawing, in order to present a greater extent of surface, to be acted upon by the heated vapours arising from the flame of the burner, and thereby warm the cold air, contained in the pipe *p, p*, more rapidly. This pipe may be made in the form of the worm of a still, or in any other form whereby an extended surface can be obtained.

The patentee claims, Firstly,—the general arrangement of the parts of the apparatus, so far as it may be new, as applied to the purposes hereinbefore mentioned; Secondly,—the employment of an earthen or stone-ware tube, for carrying off the products of combustion, in place of a metal one, as has been heretofore practised; and also the employment of a cold-air tube, for the purpose of bringing a current or stream of cold air, and causing it to impinge upon or play around the external surface of the tubes which convey away the heated air and gases, and thereby to prevent such tubes from becoming overheated.—[Inrolled in the Petty Bag Office, October, 1844.]

Specification drawn by Messrs. Newton and Son.

To ROBERT MOLLETT, of *Shacklewell, in the county of Middlesex, Gent.*, and JESSE BRIDGMAN, of *Hackney, in the county of Middlesex, Gent.*, for certain improvements in separating the fatty and oily from the membranous portions of animal and vegetable substances.—[Sealed 28th March, 1844.]

THIS invention consists in separating the fatty and oily from the membranous portions of animal and vegetable substances, by first passing them through the apparatus represented in Plate XVI., and then subjecting them to the processes hereafter described.

a, is the framing of the machine; *b, b*, a pair of rollers, with sharp teeth or narrow grooves around them, and working into one another; *c, c*, a similar pair of interlocking rollers, but formed with broader grooves, of the kind called U grooves: both pairs of rollers are heated by steam. *d*, is a hopper for feeding the rollers *b, b*; *e*, a large toothed-wheel, fixed on the axis of one of the rollers *b, b*, and driven by the pinion *f*, turned by the handle *g*; on the other end of this axis is a spur-wheel, taking into another spur-wheel on the axis of one of the rollers *c, c*, and thus communicating motion to that pair of rollers. *h*, is a screen on which the membranous portions fall, and are conducted into any suitable receptacle at the side of the machine; and *i*, is a vessel to receive the fatty and oily portions of the material operated upon.

The membranous portions delivered by the screen *h*, if not quite exhausted of fatty or oily matter, are passed a second time through the machine, or through a pair of plain rollers, mounted in a separate framing, and heated by steam. The fatty or oily matter, which collects in the receiver *i*, is heated by steam-pipes (not shewn in the drawing), until it is brought to such a state of liquefaction, that the whole, or nearly the whole, of the grosser impurities, still contained in it, fall to the bottom. The liquid portion is now drawn off, and strained through some textile fabric, such as flannel, cotton or linen sheeting, hair-cloth, &c.; it is then filtered through a bed of animal or vegetable charcoal (preference being given

to the former); and if it afterwards exhibits any trace of charcoal, it is again strained through some textile fabric.

Instead of passing the crude tallow or other substance between rollers, such as above described, it may be passed between heated metal plates, worked with a reciprocating movement; but the rollers are preferred, as being more generally applicable and convenient.

The patentees state, that they make no claim to "the diffusing of heat by means of pipes through the substances operated upon, nor to passing the same through textile fabrics, or through animal or vegetable charcoal." They claim "separating the fatty and oily from the membranous portions of animal and vegetable substances, by the combination of methods before specified; that is to say, by passing the same successively through grooved and heated rollers (or any suitable mechanical equivalents), through vessels, in which they are raised, by heating pipes, to a melting temperature, through textile fabrics, and through animal or vegetable charcoal, as hereinbefore described, or by the combination of any two of the said methods; the passing them through grooved and heated rollers, or any suitable mechanical equivalents, being one of such two methods."—[*Inrolled in the Inrolment Office, September, 1844.*]

To JAMES FENTON, of Manchester, in the county of Lancaster, engineer, for his invention of an improved combination or alloy, or improved combinations or alloys, of metals, applicable to various purposes for which brass and copper are usually employed, in the construction of machinery.—[Sealed 30th May, 1844.]

THIS invention of an improved combination or alloy of metals is intended to be used in the construction of machinery in general, in those places and situations where brass and copper are usually employed.

The improved alloy, it is stated, may be beneficially used as a substitute for the ordinary metals, in consequence of its not being liable to heat, or subject to other destructive results,

caused by friction and ordinary wear and tear ; also, by greatly decreasing the consumption of oil or grease, and being of increased durability, and much lighter weight in the same bulk of metal. All these advantages will be sufficiently evident to the practical engineer and mechanic, as well as the great variety of purposes for which this improved combination or alloy of metals may be employed in the construction of machinery, such as steps, bearings, pedestals, journals, bushes, axle-boxes, connecting-rod ends, cocks, taps, pump-barrels, pump-rams, plungers for buckets, &c., and also as a substitute for the more elementary parts of machinery, (formerly made of brass or copper,) such as rollers for calico and other printers, bowls, &c.

The manner of carrying this invention into practical effect, is to be according to the following formula :—Firstly, take 32 parts of copper, 15 parts of block tin, and 1 part of sheet brass, and mix or combine these in the following manner :—The copper being fused or melted, in a crucible, or other suitable vessel or furnace, the sheet brass is added thereto, and afterwards the block tin is thrown in ; the alloy is then poured off in ingots, and a metal is produced, which the patentee terms “hardening metal.” Under this head he claims the novel and peculiar use of these metals, to form “hardening metal ;” but the quantities may be varied, to give the alloy any required degree of hardness, or various other metals may be added, in small quantities, to effect the same purpose ; he likewise claims the use of these, in connection with copper and block tin : the above constitutes the first part of the process employed by the patentee in the manufacture of his *ultimate* alloy or alloys.

Secondly, take 2 parts of the hardening metal, previously described, 19 parts of zinc or spelter (or so many parts of calamine as shall be equal to the quantity of zinc or spelter), and 3 parts of block tin, and mix or combine these in the following manner :—First, fuse or melt the zinc, spelter, or calamine, in a crucible, or other suitable vessel or furnace, which must be sufficiently large to contain, along with the zinc or spelter, the hardening metal previously described, and the block tin last specified. The hardening metal should be

fused or melted in a separate crucible, or other suitable vessel or furnace, and then mixed or combined with the zinc, spelter, or calamine: the alloy must be well stirred, with a suitable implement, in order to render the combination of these two metals or semi-metals as complete as possible. The block tin is then added, to give the ultimate alloy or alloys the requisite degree of ductility or toughness. The whole must be again well stirred with a suitable implement, in order to render the combination of this, the ultimate alloy or alloys, as complete as possible. It may then be cast, or employed in the usual manner, in the various forms required for the construction of machinery.

While the zinc or spelter is being melted, the surface of it should be well covered with a coating of powdered charcoal, in order to prevent the volatilization of the semi-metal.

Under this head the patentee claims as follows:—"The use of these metals and semi-metals, above described, to form my ultimate alloy or alloys; but the proportions may be varied, to suit particular cases, and a variety of other metals may be added, in small quantities, the use of which I also claim, though not absolutely requisite to form my ultimate alloy or alloys. I further claim the use of the semi-metal zinc, spelter, or calamine, as the basis of my ultimate alloy; and although I have found the manner of combination above described the most effective in preparing the alloy or alloys which I substitute for brass and copper, in the construction of machinery, I claim the use of the said alloy or alloys, although combined in any other manner or proportions whatever; such combination or alloy being made, either in the exact proportions herein set forth, or in any other, within such limits as are substantially the same, and will produce a like result, as a substitute for brass and copper, to be used in the construction of machinery."—[*Inrolled in the Petty Bag Office, November, 1844.*]

Specification drawn by Messrs. Newton and Son.

To HENRY BODEN, of Derby, lace manufacturer, for an improvement in the manufacture of bobbin-net or twist lace.

—[Sealed 4th June, 1844.]

BOBBIN-NET or twist lace has hitherto been manufactured with threads formed by first spinning single cotton yarn, and then doubling it; the operation of spinning being performed in such a manner, that the twist proceeds in the direction of from right to left; and then, in doubling, the twist is caused to run from left to right, corresponding with the direction in which the bobbin carriages or traversing threads move, in bobbin-net or twist lace machinery; for otherwise, the twist which necessarily takes place in the bobbin or traversing threads, in making bobbin-net, would untwist those threads, and weaken them. Now, this invention consists in the employment of single yarn for both bobbin and warp threads, or for the bobbin threads only; and, to preserve the twist when making such yarn into bobbin-net, it is spun in the same direction as the doubling of the yarn has been hitherto performed, that is, from left to right, which is the direction required by bobbin-net or twist lace machinery, as at present arranged; but, if the direction of working in such machinery was reversed, then it would be desirable to reverse the twist.

The patentee claims the manufacture of bobbin-net or twist lace by machinery, by applying single cotton yarn as warp threads or bobbin threads, as above described.—[Inrolled in the Inrolment Office, December, 1844.]

To HENRY BESSEMER, of Baxter House, St. Pancras, in the county of Middlesex, engineer, for a new pigment or paint, and the method of preparing the same; part of which method is also applicable to the preparing and treating of oils, turpentine, varnishes, and gold size, when employed to fix metallic particles and metal leaf, or as a means of protecting the same.—[Sealed 13th January, 1844.]

THE new paint, which constitutes the chief part of this invention, is made by mixing metallic powders, (known as

bronze powder,) with gum-resins, oil, and turpentine, in such proportions as to form a fluid, capable of being used in the same way as oil paint.

The following is the mode of preparing the paint:—Into a copper or other vessel placed over a brisk fire, 8 pounds of gum-copal are thrown, and the heat is so regulated that the gum will fuse in about twenty minutes. An addition is then made of $2\frac{1}{2}$ gallons of drying linseed oil, heated to nearly the boiling point; the oil being introduced in small quantities, and the mixture well stirred up. The mixture is now boiled for about two hours (skimming off any impurities that may arise); after which it is allowed to cool to 150° Fahr., and 25 gallons of turpentine, heated to 150° Fahr., are slowly introduced, and thoroughly incorporated with the mixture, by stirring; 1 gallon of slaked lime, or other alkaline matter, is then added, and the mixture allowed to rest for three days. When this time has expired, the fluid portion of the mixture is drawn off from the lime, which will have subsided, and is then mixed with the metallic powder, in the proportion of five parts, by weight, of fluid, to four parts of powder. The metallic powders preferred by the patentee, are those manufactured by the process for which he obtained a patent on the 15th of June, 1843.*

That part of this invention which is “applicable to the preparing and treating of oils, turpentine, varnishes, and gold size, when employed to fix metallic particles and metal leaf, or as a means of protecting the same,” consists in neutralizing the acids that are combined with those materials, by the use of lime or other suitable alkaline matter.

The acids in gold size, and such varnishes as are employed to fix metallic powders and metal leaf in japanning, paper-staining, painting, &c., are neutralized in the following manner:—One pound of slaked lime is ground, by means of a mullar, with as much of the gold size or varnish as will reduce it to the consistence of ordinary oil paint, and this mixture is added to the gold size or varnish, in suitable proportions for neutralizing the acids contained therein. In

* For specification of this patent, see Vol. XXIV. of our present Series, p. 321.

treating oils, turpentine, or such varnishes as may be used to protect the metallic powders or metal leaf, the lime, or other alkaline matter, which is added to them (for the purpose of neutralizing the acid), must be subsequently separated by filtration; but if any of the oils or varnishes should not be sufficiently fluid to pass through a filter, they are made so, by the addition of spirits of turpentine, which is afterwards separated from them by evaporation.

The patentee claims, as his invention, Firstly,—a pigment or paint, consisting of bright metallic particles, combined with purified gums, oils, or spirits, in such manner, and in such proportions, as to form a painting fluid. Secondly,—the method, hereinbefore described, of preparing a fluid for the purpose of mixing with metallic particles or powder (known as bronze powder), and forming thereby a pigment or paint. Thirdly,—the combination of lime, or other suitable alkaline matter, with such gold size or varnish as may be used in fixing metallic powders and metal leaf. Fourthly,—the use of lime, or other suitable alkaline matter, for the purpose of neutralizing the acid contained in such turpentine, oil, or varnish, as may be used as a covering or protection to metallic powders and metal leaf, and the means, hereinbefore described, of effecting the same.—[*Inrolled in the Inrolment Office, July, 1844.*]

REPORTS OF AMERICAN PATENTS,

GRANTED SINCE THE 1st OF JANUARY, 1844.

From the "Journal of the Franklin Institute,"

EDITED BY DR. THOMAS P. JONES.

To SABIN COLTON, Philadelphia, Pa., for an improvement in the combination lock for doors.—[Dated 6th January.]

WE have here another of that almost endless variety of devices for preventing the picking of door and other locks, by means of impediments put in the passage of the bolt, which are intended only to be removed by setting them to a combination of letters or figures, which may, for greater security, be varied at pleasure. In the modification under consideration, the bolt is thrown in and out by a knobbed spindle and bit, and the impediment to its inward movement is a slide which works in a box attached to the back end of the door plate. When the bolt is out, and the slide

is pushed and retained in, it projects from the lock-plate, and behind the bolt, far enough to be a complete check, and is retained in that situation by buttons, or discs, on the ends of three or more spindles that work in the slide. These buttons, or discs, have a portion of their diameter cut off, so that in one situation they are narrow enough to pass with the slide through the box, and in other situations they project beyond the width of the slide, and catch on to a piece which projects from the back of the plate; the forward end of these spindles is adapted to receive a key, by which they are turned, and by figures, or letters, marked on the key and door-plate, the combination desired can be formed and pointed out as in the Bramah lock. The patentee claims "the manner in which he has combined the slide contained in the box, and the spindles therein carrying the buttons on their ends, which are made to catch on the piece projecting from the back of the lock-plate, when acted upon by the key; said apparatus operating, as a whole, substantially as described.

To GEORGE R. MOORE, *Brattleboro', Vt.*, for an improvement in platform spring scales.—[Dated 6th January.]

INSTEAD of attaching, or suspending, the article to be weighed to a rod attached to a spring, according to the usual mode of making spring scales, it is placed on a platform attached to the top of a vertical rod, suspended, by the ends of a cross bar attached to it, to two arms of a rock shaft, which is also provided with two other arms opposite them: to one of these the spring is attached, and to the other, which is longer, is suspended a dish to receive the weights for weighing beyond the force of the spring. From one end of this rock shaft another arm extends down, and is jointed by a link to an index hand, turning on a pivot, which points to the graduations on an index on the box that surrounds the whole, except a portion of the hand, and the end of the lever to which the dish is suspended. The lower end of the rod to which the platform is attached, is kept in a vertical position by a jointed bar, in the usual way.

The claim is limited to the "combination of the spring balance, with the steel-yard, substantially, in the manner described." "And, also, in combination with the above, the hand, or indicator, and index, arranged as specified."

To WILLIAM H. BRAYTON, *Warren, Bristol county, R. Island*, for an improved let-off motion for regulating the delivery of the yarn in weaving-looms.—[Dated 6th January.]

THE yarn-beam is, by means of a cog-wheel and pinion, put in connection with a friction-pulley, around which passes a friction-band, having one end fixed to the frame by a screw adjustment, and the other by means of a rod, or spring, to the lower end of an upright lever, jointed to one of the swords of the lathe, the

upper end of which is jointed to a finger, or short arm, projecting downwards from a small shaft extending across the back of the lathe; and from this shaft project upwards two other arms, or fingers, which bear against the back of the flighter, or spring reed. The yarn is not given out by the beam unless the friction-band, on the friction-pulley, is loosened, which does not take place until the strain of the web, in beating up, be sufficiently great on the flighter, or spring reed, to cause it to yield, and then, by the connection above described, the friction-band is loosened, and the yarn given out.

The claim is limited to the "mode of connecting the yarn-beam with the flighter, by means of the friction-strap and pulley."

To AARON E. JAMES, *Point Pleasant, Mason county, Va., for an improvement in bee houses.*—[Dated 6th January.]

THE patentee says :—"What I claim as my invention, and desire to secure by letters patent, is the combination of several hives furnished with inclined floors, and two honey-boxes on their tops, with the bee palace in the manner set forth; that is to say, said hives being moveable, and having the entrance for the bees in the middle, between the two inclined floors, and corresponding to an entrance in the floor of the palace, said entrance having an inclined alighting board, and slides to close the hives at pleasure."

To JOHN BOOTH and WILLIAM H. STEVENSON, *Columbus, Lown-des county, Miss., for a machine for moulding brick.*—[Dated 6th January.]

In this machine there is a cistern, with a vertical shaft and arms, for mixing, or tempering, the clay in the usual manner. This cistern is square, and its bottom is pierced with four holes, corresponding with the four sides of the cistern. Below this cistern the frame is adapted to receive two mould-frames that run entirely across, at right angles to each other, and so let into each other as to slide freely at right angles, and have the tops of all the moulds (which are placed one set at each end) level, and as nearly in contact with the bottom of the cistern, as may be consistent with the operation of the machine. The moulds are filled in succession by an inclined board, called the filler, attached to an arm near the lower end of the mixing-shaft, which, in passing around, forces the clay through the holes in the bottom of the cistern, into the different sets of moulds in succession. Below the filler there is a curved arm attached to the shaft, which acts as a cam to move the mould-frames, that are provided with rollers, on opposite sides, for this purpose. After the filler has passed over and filled a set of moulds, the cam follows, and pushes it out, and the opposite set in, to be in readiness for the filler.

The claim is in the following words, viz. :—"What we claim,

as our invention, and desire to secure by letters patent, is the method of filling and returning the moulds, as described; that is to say, by means of the follower, or filler, and the curved lever, (cam) combined, operating, and arranged, substantially, as set forth. And we also claim the manner in which we have combined with the cistern, and its revolving shaft for tempering the mortar, the mould carriages constructed, and operating, substantially, as set forth."

To JOHN CLINE, *Norwalk, Huron county, Ohio, for an improvement in the air-tight stove.*—[Dated 6th January.]

THIS improvement consists in adding to the well-known air-tight stove a small pipe, which extends from the front of the stove to the smoke-pipe, or valve-plate, with the end turned, and extending a short distance up the smoke-pipe, for the purpose of giving a slight draught to carry off the gases and vapour generated in the stove. The claim is limited to this improvement.

To WILLIAM J. ROOME, *city of New York, for a composition of matter for rendering water-proof articles manufactured of leather, such as boots, shoes, &c.*—[Dated 6th January.]

THIS compound consists of "32 parts mutton or beef tallow, either or both, 32 parts linseed oil, 24 parts yellow bees'-wax, 6 parts neats' foot oil, 4 parts lamp-black, and 2 parts litharge, or red lead." We are instructed to "place the materials in a pot of sufficient size, and reduce the materials to a liquid mass, by the application of heat: when all is melted, to keep stirring the composition until it becomes nearly cold, or while in the liquid state to fill it into tin or earthen vessels, for use."

To CONSTANT B. BUTLER, *Petersburg, Lincoln county, Tenn., for an improvement in the flax and hemp breaker.*—[Dated 6th January.]

IN the breakers heretofore known and used, the swords, or blades, that break the flax, or hemp, only act on it in one direction, and the object of the present improvement is to arrange them in such manner that they will act on both sides of it, and thus more effectually break the woody part. This is done by having two sets of permanent swords, or breakers, sufficiently far apart to receive the flax, or hemp, between them, and two sets of moveable swords, or breakers, attached to a sliding frame or gate, one set acting on the upward, and the other on the downward, movement of the gate.

Claim.—"What I claim as my invention, and desire to secure by letters patent, is the construction of the breaker by which the hemp, or flax, is acted upon in the upward, as well as the down-

ward, stroke, thus acting on the opposite sides of the hemp ; that is to say, I claim the combination of the upper and lower permanent breakers, or sets, with the upper and lower blades attached to the moveable sash ; this being the principle of the invention which I desire to secure."

To JOSEPH S. IVES, *Bristol, Hartford county, Conn., for a mode of straining the strings in the act of tuning pianos.*—[Dated 6th January.]

THE patentee says,—“In my improved method of straining the strings of piano-fortes, &c., instead of the ordinary tuning-pin, I employ, with each string, a tuning-pin which has a screw on it, intended to operate as an endless screw upon a worm-wheel which turns on pivots in a proper metallic bearing. The worm-wheel has a groove turned in it for the purpose of receiving the wire which is to be strained thereon. The lower part of the tuning-pin is enclosed by a metallic socket, which is driven into the tuning-pin block, where it is held permanently.

“What I claim as new therein, and desire to secure by letters patent, is the manner of forming and combining the tuning-pin, the worm-wheel with its grooves, and the metallic support in which they turn, so as to receive and give tension to the respective wires, as set forth.”

To DAVID SMITH, *South Hill, Brunswick county, Va., for a machine for preparing hands, or bundles, of tobacco, for being packed.*—[Dated 15th January,]

THE object of this invention is to press the hands, or bundles, of tobacco, by means of rollers so arranged that the bundles of tobacco will come out of the machine in a regular form. The rollers are arranged like the rollers of a copper-plate press, except that the upper one is grooved, and that there are guide-pieces on the bed of the press which fit into the grooves of the rollers, the space between the grooves and guide-pieces being equal to the desired width of a bundle, or hand, of tobacco.

Claim.—“What I claim as new, and desire to secure by letters patent, is the combining of the guard, or guide pieces with a pair of rollers, one of which is furnished with rectangular grooves ; the respective parts being so arranged as to produce the intended effect, substantially, in the manner set forth, together with such variations of the same as leave its principle of action unchanged, producing a like effect by equivalent means.”

To SIMEON WOOD, *Worcester, Mass., for a machine for shaving shingles.*—[Dated 15th January.]

IN this machine the shingles are shaved on both sides, by means of two shaving knives, that are made to approach each other by

two sets of cams, that act on arms projecting from the stocks of the knives. These two sets of cams are arranged on the shafts of two cam-formed rollers that draw the shingle through between the knives; they are so formed as to hold on to the wedge-formed shingle equally from butt to point, and, therefore, they must have the form of a volute; the cams that act on the knives being of the same form. The ends of the stock of the under knife turn down at right angles, and work up and down freely in the frame, and are hollow, to receive freely the turned-down ends of the upper knife; these resting on helical springs at the bottom, which tend constantly to separate the knives when liberated by the cams. The shingle-bolts are fed to the knives by turning-rests, joined to two endless chains passing over rollers, and these rests are provided with arms that bear on guide-ways, to prevent them from turning until they reach that portion of their circuit where they descend, at which time the arms have reached the end of the guide-ways, which liberates the rest, and permits it to leave the end of the shingle-bolt, which is then drawn through by the cam-rollers.

The patentee says,—“ I am aware that a patent has been granted to another person for a shingle machine, in which the shingle is shaved and tapered by means of two knives, that are made to approach each other as the shingle passes through, and therefore it will be understood, that I do not claim this as of my invention; but what I do claim as my invention, and desire to secure by letters patent, is, the combination of the cams that force the knives to approach each other, with the cams that draw the shingle between the knives, substantially, as described; and I also claim the described arrangement of the stocks to which the knives are attached, by making the ends of the upper one slide in the hollow ends of the under one,—springs being interposed between their ends, to force the knives apart at the end of each operation. And, finally, I claim the turning-rests for feeding the shingles, in combination with the chain and guide, for the purpose and in the manner described.”

Scientific Adjudication.

COURT OF COMMON PLEAS.

Sittings in Banco,—Nov. 5th, 1844.

BENTLEY v. FLEMING.

A MOTION was made by Sir T. Wilde, to set aside the verdict which had been entered for the plaintiff in this case, with 40*s.* damages, upon the ground that the verdict was contrary to evi-

dence ; and, also, that there had been a miscarriage in returning and recording the verdict itself. The action, which was for the infringement of a patent, granted to Thornton, and by him assigned to the plaintiff, was tried before Mr. Justice Cresswell, at the last Liverpool assizes.* The trial occupied two days, and having concluded at a late hour on Saturday night, the learned Judge wrote down three questions for the jury on a piece of paper, which was handed to the foreman when the jury were about to retire. His Lordship then left the court, and the jury, after a long absence, returned into court, where they found the associate and the junior counsel on each side, waiting to receive the verdict. The foreman having been asked for whom the jury found, replied, "We find for the plaintiff;" and upon hearing this statement, the junior counsel for the defendant requested the associate to ask the jury what answers they gave to the three questions left to them by Mr. Justice Cresswell. The junior counsel for the plaintiff, however, protested against any questions being put to the jury, and the associate accordingly declined to interfere, and entered the verdict for the plaintiff. On the Monday morning one of the jury, Mr. James Smith, addressed the learned Judge, and said that the verdict of the jury had been mistaken ; and it appeared to-day, from an affidavit of one of the jury, that they were of opinion that there had been an infringement of the patent, and that the original patentee was the first and true inventor ; but that, upon the third question left to them by Mr. Justice Cresswell, they had found that the invention was in public use before the patent was granted. Upon this ground, the learned serjeant contended, he was entitled to a rule to shew cause for a new trial ; and he also submitted that there had been no evidence given at the trial of an infringement of the patent by the defendant.

The Chief Justice, Sir N. TINDAL.—The general rule is, that we cannot hear any thing that goes to impeach the verdict of the jury ; but what took place in this case occurred in open court. You may take a rule *nisi* on both points.

November 30th, and December 2nd and 3rd, 1844.

WOODCROFT v. REYNER AND ANOTHER.

THIS was an action brought by the plaintiff, as proprietor of letters patent granted to him, January 4th, 1838, for his "invention of improvements in the construction of looms, for weaving various sorts of cloths ; which looms may be set in motion by any adequate power †," against the defendants, spinners and

* See p. 199, of our present volume.

† See Vol. XIV., p. 159, of our present Series.

manufacturers, at Ashton-under-Lyne, for recovery of damages in respect of an alleged infringement of the patent.

Mr. Watson, Queen's Counsel, Mr. Cowling, and Mr. Rotch, were for the plaintiff, and Mr. Martin, Queen's Counsel, Serjeant Channell, and Mr. Webster, for the defendants.

This action was brought for the infringement of the plaintiff's patent right in what is called a tappet, which is an instrument used in looms for determining the pattern of figured or fancy cloths. The tappet in use before the plaintiff's, usually called Bowman's tappet, consisted of a number of solid circular plates, with prominences, causing the requisite elevation or depression of the warp-threads; and, when a new pattern had to be made, it was requisite, generally, to purchase new plates, or re-cast the old ones. The plaintiff's patent claimed the mode of dividing these plates into sections, corresponding with each other, so as to be transposable, and form a new tappet-plate, and thus to effect an almost infinite variety of patterns out of the same plates, by merely transposing the sections, without breaking up the plates. The plaintiff alleged, that the defendants had borrowed the idea of their tappet from the patent tappet, and that it was a mere mechanical equivalent, identical in principle.

The defendants contended, that the patented invention was not new, inasmuch as moveable corresponding sections or tappets had been long before employed for a precisely similar purpose, and with the same effect, and produced various working models of the same in support of the defence; and also that their instrument was of an entirely different construction.

The case having been fully investigated, the jury retired to consider their verdict, and after an absence of nearly two hours, a proposal was made to come to terms in court, which resulted in a verdict being taken for the plaintiff, with nominal damages, and upon consideration, that the defendants should be allowed to continue to use the machinery, the subject of the alleged infringement, upon terms which had been arranged between them. The Judge having announced to the jury that the matter had been arranged between the parties, at once certified, on the back of the record, that the merits of the case had been fully investigated.

*Sittings at Nisi Prius, at Westminster, before the Chief Justice
Sir N. Tindal and a Special Jury.—Dec. 4, and 5, 1844.*

BENTLEY v. CARVER.

THIS was an action brought to recover damages for the alleged infringement of a patent right, granted December 21st, 1841, to William Carr Thornton, who assigned the patent to a person named Williamson, and he again to the plaintiff.

Mr. W. H. Watson, Mr. Serjt. Channell, and Mr. Webster,

were for the plaintiff; and Mr. Kelly, Mr. Cowling, and Mr. Pigott for the defendant.

The defendant pleaded all the defences which are usually set up in actions of this nature; namely, that there had been no infringement; that Thornton was not the true and first inventor; and that the invention was in public use before the patent was granted.*

The invention claimed by the plaintiff consisted of an improvement upon Dyer's patent card-making machinery, for introducing metal teeth into sheets or fillets of leather, for the production of cards or wire brushes, used for the purpose of combing wool and cotton.

The machines employed for this purpose, according to the plans of the plaintiff and defendant, were brought into court; but it would be impossible to convey a correct idea of their construction without very elaborate drawings. The patentee's improvements consisted principally in a novel mode of constructing and working the head-work or frame of the machine, by which a stationary distended sheet or strip of leather was pierced with a series of holes, and the staple-formed wires inserted in rows into the leather, and bent up to form the inclined teeth. This was effected by the traversing and reciprocating movements of the head-work or carriage, which contained the ordinary mechanism for performing the work upon a stationary distended sheet: the distinction between this and the original machinery of Dyer's being, that, in the improved plan, the head-work, with the piercers, &c., moved to and fro, whilst the distended sheet remained stationary; whereas, in the old mode, the sheet moved to and fro, to be acted upon by the piercing and inserting apparatus, which were locally stationary.

The alleged improvements introduced, under the patent of the plaintiff, were said to afford greater facilities of operation, and considerable economy in space. Other features of improvements claimed, consisted in the modes of raising the distended sheet or strip of leather, after every row of wire teeth had been completed, for the purpose of piercing a fresh row, and introducing, in the same way, a similar series of wire teeth, in regular order; a mode of inclining the sheet or strip of leather to any required angle; and also the adaptation of strengthening bearings and springs, to assist the operations.

Many practical and scientific witnesses were called by the plaintiff, to prove the advantages resulting from the new arrangements, and improved modes of working his patent machinery; and likewise the identity, in principle, of his and the defendant's machine, employed for the same purpose. Witnesses, both practical and scientific, were also called on the part of the de-

* See also account of previous trial for infringement of this patent, *Bentley v. Fleming*, p. 199 of the present volume.

fendant, who considered that the alleged invention of the plaintiff was no invention, but merely a transposition of old and known mechanism, rendering that moveable which was before stationary, and that stationary which before was moveable.

The trial lasted two days, and after the Chief Justice had pointed out to the jury the main features of the evidence, and the matters for their consideration, a verdict was returned for the plaintiff, with forty shillings damages, (being sufficient to maintain the validity of the patent, and carry costs of suit).

COURT OF QUEEN'S BENCH.

Before Lord Chief Justice Denman.—Dec. 7th, 1844.

THE QUEEN v. NEWTON.

THIS was an action, under a writ of *scire facias*, to set aside a patent granted to the defendant for "improvements in preparing and purifying fatty matters (being a communication from a foreigner residing abroad)."

Mr. Platt appeared for the prosecution, at the instance of Messrs. Wilson & Co., tallow-merchants, who, having failed in a negotiation to purchase the patent-right of the defendant, wished to relieve themselves from any presumed infringement of matters contained in the specification of the said improvements, should they hereafter think proper to employ, in their own manufactory, any parts of the process therein set forth; and to do this, instituted these proceedings, calling upon the Crown to annul the patent, under the pleas, that the invention was not new; that it was not a manufacture, but merely a statement of experimental results; that the statements were not true, or calculated to produce the proposed effects; that the specification mentioned things which were impracticable, from their expensiveness; and several other pleas, concluding with, that the invention is of no use, and that therefore the patent ought to be repealed.

One witness only was examined to prove these allegations, who stated it to be his opinion, that some of the parts of the processes pointed out had been used before, for preparing and disinfecting fatty matters.

Mr. Baynes appeared, on the part of the defendant, to watch the proceedings, and stated, that the defendant (Newton) was only nominally interested in the patent-right, being merely the agent of a party residing abroad, on whose behalf he had obtained the patent in question, and at whose desire he, the defendant, had inrolled the specification of the said invention, in the words, and with the drawings, communicated to him by the inventor. That since the negotiation for the purchase of the patent had been broken off, he, the defendant, had not been able to obtain from

the proprietor of the patent, residing abroad, any replies to his letters, or any instructions as to defending this action; and that therefore, being thus circumstanced, the learned counsel must leave it to his Lordship and the jury to say, whether the allegations set out against the validity of the patent had been sufficiently proved.

His Lordship said, that as a part of the process described in the specification had been asserted by the witness to have been before the public, prior to the date of the patent, that defective point vitiated the whole, and consequently the jury must find a verdict for the Crown, which they accordingly did.

COURT OF COMMON PLEAS.

Sittings at Nisi Prius, at Guildhall, before the C. J. Sir N. Tindal, and a Special Jury,—December 16th, 17th, and 18th, 1844.

MANGNALL AND ANOTHER *v.* M'ALPINE.

THIS was an action brought by the plaintiffs, as assignees of a patent taken out by Messrs. Thomas Ridgway Bridson, and William Latham, in the month of May, 1838, for their invention of "certain improvements in machinery or apparatus for stretching, drying, and finishing woven fabrics*," against the defendant, a bleacher at Hammersmith, for recovery of damages, in respect of an alleged infringement of the patent.

Serjeant Sir Thomas Wilde, Serjeants Shee and Byles, Mr. Crompton, and Mr. Atherton, were for the plaintiffs; Mr. Jervis, Serjeant Channell, and Mr. Webster, appeared for the defendant.

The pleas were numerous and special, raising eight or nine several issues; amongst them were not guilty,—that the invention was not a new manufacture within the meaning of the statute,—that it did not appear by the specification what the patentee claimed as his invention,—that the title of the patent and the specification did not accord,—that the letters patent had been assigned, by deed, to more than twelve persons, contrary to the condition contained in them,—that the invention was not new, but had been previously publicly known and used, &c.

It appeared, upon the opening of Serjeant Sir Thomas Wilde, for the patentee, that Messrs. Bridson and Latham had together invented the machine, and that its object was to produce a soft elastic finish upon muslins and other fabrics, by means of a horizontal reciprocating vibratory movement of longitudinal bars or frames, between which the cloth or fabric was distended to its full length, being previously attached to the frames by small tenter-hooks. When thus attached, the motion was applied or given to the frames, and the threads of the cloth thus drawn into diagonal

* See Vol. XIV. of our present Series, p. 294.

positions, and alternately reversed, at each vibratory movement of the frames, whilst in the process of drying, and until that process was complete :

That, previous to the patentee's invention, it was a known practice to pull the cloth by hand, three or four persons being stationed on each side, for the purpose of "thumbing," as it was termed, and that this thumbing process was carried on for the same purpose as that contemplated by the patentee, viz., producing a soft or pliable finish upon the cloth :

That, for some time previous to the date of the patent, the patentee had directed his attention to the question, whether some other mode or mechanical apparatus might not be adopted, by which the required, and at the same time a more regular and equal reciprocating action, might be imparted to the threads of the cloth, during the process of drying, with reference to the result previously alluded to ; that accordingly he had made certain experiments, and that those experiments had resulted in the present patent :

That Latham had, by deed, subsequently transferred to Bridson his (Latham's) interest in the patent, whereby Bridson had become sole owner :

That, with reference to the alleged assignment, by which it was said that the patent had been assigned or transferred to more than twelve persons, contrary to the proviso in the letters patent, a deed had been executed by the patentee, Bridson, purporting to be an assignment of his property, and of the letters patent in question, to three persons, *i. e.*, the two present plaintiffs, and a Mr. Hick, since deceased, upon certain trusts for the benefit of creditors.

The learned Serjeant then stated, that the legal construction to be placed upon this deed might be matter for discussion in another place, but would not be a question with which the jury had to deal ; it appeared that the trusts of the deed had been long since satisfied, the patentee's creditors having received 20s. in the pound upon their debts, with interest, and that they were respectively-executed trusts at the time of the commencement of the present action.

That, to establish the question of infringement by the defendant, several civil engineers would be called before the jury, who had viewed the defendant's premises, under an order granted by the Vice Chancellor, and that their evidence would be sufficiently conclusive to satisfy the minds of the jury upon that part of the case,—that the specification was sufficiently lucid, both as regarded the invention of the patentee, the machine, its mode of working, and the object to be accomplished, "an improved elastic finish," and according with the letters patent themselves.

He also touched slightly upon the other points raised by the pleadings, stating that they were matters resting with the Court, and not coming within the province of the jury.

On the part of the plaintiff, Mr. John Farey, Dr. Ure, Mr. Cooper (of King's College), Mr. Cubitt, Mr. Carpmael, Mr. Bodmer, of Manchester, and other civil engineers were called, who severally gave an elaborate explanation of a model of the plaintiffs' machine, which was produced, and manifested its parts, their use, and application, and the effect produced upon the cloth; that in their experience they had not met with any thing of a similar description, as applied to the particular purpose described in the specification; that the improvement in the finish of cloth was very great, and valuable in trade; that the specification, and drawings attached, sufficiently set forth what the patentees' invention was, so as to enable any competent mechanic to construct one of the same kind; and that, although the separate and distinct parts of the machine might not be new, their combination and adaptation for the purpose of finishing cloth was new, and had not been known before.

The plaintiffs also called several bleachers from various parts of Lancashire, and others from Lanarkshire and Renfrewshire, who severally gave testimony in aid of the novelty and usefulness of the invention.

A witness was also called and examined, in anticipation of the defendant's case, to prove that he had been employed at the works of Messrs. Fisher, in Renfrewshire, for a considerable length of time, and had never seen any machine used by them having the vibrating motion, or similar in description to that of the patentee.

To substantiate the usefulness of the invention, it was proved that Bridson had finished nearly 70,000 pieces upon the patent process during the first five months of the present year.

Mr. Jervis, for the defendant, maintained that the plaintiffs should be nonsuited on one of two grounds; first, that the specification was not in accordance with the title of the patent, "certain improvements in machinery or apparatus for stretching, drying, and finishing woven fabrics;" and next, that the specification was defective and ambiguous, not shewing what the patentee claimed as his invention.

His Lordship consented to take a note of the objections, *declining to nonsuit* the plaintiffs, and directed that the case should proceed.

For the defendant, evidence was given by the Messrs. Fisher, (previously named,) who produced and explained the model of a machine, used by them in 1830, and long prior to the plaintiffs' patent, and in which it was maintained the same vibratory motion was found, and had been applied with a similar result. On cross-examination of these witnesses, it was admitted they had only used the machine for a period of six months, and then laid it aside again, adopting the previous mode of finishing their cloth.

Three other several models were produced, by distinct witnesses, all of which were alleged to have been used in different

parts of Scotland, at different works or premises, and to a considerable extent; but it did not appear that they had continued the user. One of the witnesses stated, that the machines, of which he produced a model, had been used in the year 1822; again, another produced a model of one stated to have been used between the years 1795 and 1800.

Sir Thomas Wilde, in reply for the plaintiffs, maintained that there was not evidence of such a public user as to defeat the novelty of the patentees' invention, and explained the extent to which the cases had gone, citing *Cornish v. Keene*, *Jones v. Pearce*, and *Neilson v. Harford et al.*

The Chief Justice charged the jury at great length, observing upon the difference existing between those instances where numerous unsuccessful endeavours and experiments had been made, but had not terminated in any useful result, and those where a party had brought to perfection and extended use any particular process or invention, directing them, that if they were of opinion that Bridson and Latham had first introduced the invention into public use, their verdict would be for the plaintiffs; but if they were of opinion that the inventions, given in evidence by the defendant, were identical, and that such public use had been known before the patent, they would find for the defendant.

The jury retired for a few moments, and returned with a verdict for the plaintiffs. The Judge granted the certificate on the back of the record, to entitle the plaintiffs to treble costs in any future action.

Scientific Notices.

REPORT OF TRANSACTIONS OF THE INSTITUTION OF CIVIL ENGINEERS.

(Continued from p. 134.)

[The delay in publishing the Minutes of the Proceedings of this Society was caused by a new regulation of the Council respecting the issue of these Papers.]

Mr. Green exhibited, and promised a copy of, a design for a stone bridge, of eight semicircular arches, which was proposed to be built over the Tyne, for uniting Newcastle and Gateshead at the high level, instead of as at present descending on one side by steep and inconvenient streets, to rise by as bad an acclivity on the other bank. The injurious effect of this had long been felt, and many designs had been brought forward for remedying it; among others he had, in conjunction with his father, proposed a bridge of four arches of bent timber, to cross the river in the same place. Cast-iron had also been thought of, and designs

were made for using it ; but, notwithstanding the present low price of that material, it was found that a stone bridge would be as cheap, and he believed that the plan now exhibited would be carried into effect.

Mr. Green presented some specimens of ornamental bricks, which he had used extensively for the decoration of the fronts of buildings ; they were made by Mr. Barnes, of Newcastle-upon-Tyne, who had found a method of giving them unchanging colours. He also promised an account of this manufacture, and of the use of these bricks for ornamental architecture.

Colonel Leake was of opinion, that the arch was known to the Greeks in very early times. In the remains of Tiræus there were galleries, the roofs of which were formed by stones meeting at an angle, and supporting each other ; they required only a third, or key-stone, to form an arch. Those who were opposed to the belief, that the more ancient Greeks were acquainted with the arch, admitted that the light broke in upon them in the time of Alexander the Great. They asserted that all masonry, in which arches were found, was posterior to that time. They would not allow the style of masonry, called Polygonal or Pelasgic, to be any proof of an earlier age ; affirming, that near Rome Pelasgic masonry was found, of a date as late even as that of the Roman Empire. Colonel Leake believed this to be correct ; but he contended, that although the substructure of the Appian Way might exhibit some Polygonal masonry, and although an opulent Roman might have indulged his fancy by giving a Pelasgic basement to a new palace or villa, there could be no question, that the immense number of Pelasgic fortresses in Greece and Italy, were all anterior to the time of Alexander.

After the conquest of Greece by the Macedonians, a few repairs and additions might have been made to the fortifications, constructed by the cities in the plenitude of their power ; but the greater part of the smaller towns were soon afterwards depopulated, and their old walls were neglected. In Greece, therefore, arches in Pelasgic masonry were, he contended, older than the time of Alexander.

Colonel Leake exhibited a drawing, from sketches made by him, of some arches in the walls of Œnia, or Œniade, in Acarnania, which were described in his "Travels in Northern Greece." Mr. Mure's "Journal of a Tour in Greece" contained drawings of other arches at the same place. One of the sketches represented a door at Œnia, which was not formed on the principle of the arch, but might serve, with the others, to shew the great variety of ways in which it pleased the Greeks to crown their doorways. In the larger arch, Colonel Leake observed, that the junctions of the stones did not converge accurately to a centre, and he had made the same remark as to other arches, both at Œnia and elsewhere ; so that it would appear, that in the solid masonry of the Greeks, the stones having sufficient mutual sup-

port, without an accurate convergence, the principle of the arch was not strictly attended to, until ancient solidity gave place to a mode of building less solid: a more correct and careful knowledge of the arch therefore became necessary. In Roman buildings, in which ostentation and rapid execution were the leading objects, the arch entered more largely, and this at once accounted for the very rare occurrence of the arch in Greek buildings, compared with the Roman. Another cause of its absence, was the accidental circumstance, that almost all extant Hellenic remains, except fortifications, were those of temples, that there was necessarily a great similarity of construction in them, and that the arch was never required in them.

There could be little doubt, that the arches in the ancient works of Volterra and Perugia were, like the Cloaca Maxima at Rome, of the times of the Roman monarchy, or of the early republic: for it was in those times only that the Etruscans were sufficiently powerful and independent to build extensive fortifications. After the Roman conquest, no defences at all would have been permitted.

The arts of Etruria were derived originally from the Pelasgi of Greece, and were refreshed by colonies from the same country, in the first or second centuries of Rome, as was confirmed by the similarity of Greek and Etruscan arts and manners, through the whole course of their history.

If existing remains seemed to shew that the Etruscans employed the arch more frequently than the Greeks, the difference of materials in the two countries might perhaps be sufficient to account for it; the marbles and hard limestones of Greece were more suitable to a length of architrave or breadth of opening, than the smaller stones of Etruria.

It was requisite to be cautious, in supposing that there was anything connected with architecture of which the Greeks were ignorant, at the time when they erected the splendid monuments which still remain. Formerly, it was questioned whether the Greeks possessed the knowledge of making glass: it is now ascertained that the Romans, the Greeks, and the Egyptians carried it to a degree of refinement, which modern nations have not yet been able to imitate. It was only recently discovered that the Greek architectural word ENTASIS was applicable, and probably applied by the Greeks, not alone to an individual column, but to an entire building.

It was now found, that there was scarcely a right line in the Parthenon; that the pavement on which the columns rested was not level, but convex; that the columnus had not only a curved profile, but that they inclined inwards; and that there was scarcely a stone, even of the columns, that would fit any place but its own. The Greeks had lately ascertained this practically, when endeavouring to restore some of the fallen masses to their original situations. The variety of curves in the archi-

trave and cornice, as ascertained by Mr. John Pennethorne*, is even still more extraordinary.

March 12, 1844.

The PRESIDENT in the Chair.

“Account of the Town and Harbour of Pulteney-Town (Wick, Caithness), from their origin in 1803 to the year 1844.”—
By James Bremner, M. Inst. C.E.

Pulteney-Town and Harbour, situated in N. latitude $58^{\circ} 26' 45''$ and W. longitude $3^{\circ} 3' 56''$, are the property of the British Fisheries Society, which was established under Acts of Parliament, for the purposes of extending the fisheries, and improving the sea-coasts of North Britain. They were, under these Acts, empowered to construct this harbour, which, with the town, was planned by Mr. Telford, in 1803; both are located upon the property of Sir George Dunbar, of Hempriggs, and are separated from the burgh of Wick by the river, which is spanned by a stone bridge of three arches, with a clear water-way of 156 feet: it was built in 1805 by Mr. G. Burn, also from the designs of Mr. Telford.

In the same year, the old or north harbour was commenced. With the exception of the pier heads, which were founded by the author, for the contractor, at a depth of 4 feet below low-water mark, the outer walls were all constructed above that level, on a bed of blue clay, mixed with stones. The works were of ordinary construction, having behind the face-walls clay puddle, within which, sand was used as hearting. A mass of boulders, whose tops reached the level of half tide, lay outside the pier heads, and protected them from the action of the sea. This harbour was finished in 1811, at an expense of £16,400.

The bed of Wick Bay is sand to a considerable depth; this sand, when disturbed by storms, is driven in great quantities to the head of the bay, where the river empties itself into the sea; with freshes, in easy weather, the river carries the sand thus lodged near its course, towards the harbour entrance.

The north harbour thus soon became nearly filled with sand, from the nature of its situation and the position of its entrance, and owing to this, and the very small rise of tide at this place, the depth of water in the interior, with ordinary spring tides, did not exceed 8 feet 6 inches.

The rise of tide at Pulteney-Town is, with neap-tides, 5 feet; with ordinary springs, 9 feet 6 inches; and, with extraordinary springs, from the point of the lowest ebb, to that of the highest flow, is 13 feet. From this some idea may be formed of the difficulty of making a harbour, sufficient for the ingress and

* Vide “Pennethorne’s Topography of Athens,” 2nd edition, p. 573.

egress of the ordinary size of vessels, even with spring tides ; so that, to obtain a sufficient depth of water, it was requisite that the piers should be formed under low-water mark.

To account for this limited rise of tide is not difficult. The Bay of Wick is only 17 miles from the east entrance of the Pentland Frith, which separates the Orkney Islands from the mainland. This frith, or strait, being only 7 miles wide, is quite inadequate to communicate each tide to the Moray Frith, the rise and fall of the North Atlantic ocean on its western side. From this source, the tide in it flows for $7\frac{1}{2}$ hours at the rate of 11 miles an hour ; while from the Moray Frith, at the north side of the mouth of which Pulteney-Town is situated, it ebbs only $4\frac{1}{2}$ hours, on account of the barrier formed by the Orkney Islands ; accordingly, vessels bound to the eastward find no difficulty in getting through this strait ; while those proceeding westward having so limited a tide, are often put back from near Cape Wrath in attempting to get round it.

The north harbour was first used by coasting-vessels, which at that time were of a very small size, from freights being so high as to enable the smallest class of vessels to pay well. After the conclusion of the continental war, however, freights were lowered, so that small vessels, for which this harbour was only fitted, could no longer be lucratively employed. This occasioned the use of vessels of a larger draught of water, which rendered the north harbour almost useless.

The practice of partially loading in the harbour, and finishing in the bay by means of boats, was not only attended with extra expense, but also, in many cases, with the loss of lives and property, owing to the very great exposure of Wick Bay. This, together with the cost of removing the sand that accumulated in the harbour, and the rising prosperity of the town, led to the erection of the south harbour in deeper water. This prosperity was chiefly induced by the success of the herring fishery, for which Pulteney-Town has always sustained a high reputation, and it is now perhaps the largest fishing-port of the kind in Great Britain.

The survey for the south harbour was made by Mr. J. Mitchell, and his plan for it, after being revised by Mr. Telford, was adopted in 1823. The contract, which embraced the present quay, and 175 lineal feet of the south pier from the inner angle, was let to the author, and in 1825 he was directed to extend this pier 100 feet further ; in 1826 he was again called upon to construct an extension of the south pier to its present length, a great part of it being from 4 feet to 8 feet under the line of the lowest spring tides. In the same year, the author entered into a contract for building the north pier ; building and embanking the jetty ; making an opening from the south to the north harbour ; and closing in the old entrance of it ; and for completing the harbour as it remains at present.

In preparing to carry on these works, two powerful barges, of 40 tons and 60 tons burthen respectively, were built; one of them having one crane, and the other two cranes, on a new construction. By means of a double line of railroad to the quarry, a plentiful supply of stones was procured at all times. The barges were also, in good weather, enabled to carry stones from a part of the bay about a mile without the harbour, and were worked with safety and expedition, by means of track-lines laid out in the direction of the loading-place. The importance of having a large supply of materials for a work of such magnitude and hazard, will at once be seen, when it is stated, that only about 24 weeks in the year are fit for carrying on such works. Aware of this danger, and of the heavy nature of the work of forming the last 100 feet of the south pier, the author had a large number of masons, quarriers, lightermen, and other men employed night and day in the season of 1827, and had made rapid progress towards its completion. All would have been finished by the 20th of September of that year, but unfortunately on the 10th of that month a violent storm arose, and, notwithstanding the temporary blocking up, which was used as a precautionary measure, about 100 feet of the pier head were swept down in one tide, to the level of low water. From having to bond the last portion properly with the end of the former, this joining was laid open, and 20 feet within it was also laid in ruins by the next tide. The stones were carried to a distance of nearly 100 feet from the work, by the force of the sea, and chiefly into deep water.

To prevent the breach from spreading, and causing the destruction of the whole work, 50 shipwrights, and 300 masons and labourers were employed, in placing nearly 40 tons of chain cables round the open end, and upon the pitching of the roadway, and fastening them securely inwards; this was accomplished in two tides, although the storm did not abate. Very large stones were afterwards laid on the open end; this proceeding, with due attention to the chains, was a means of avoiding the destruction of the whole work, during the stormy winter that followed; as it was, the loss sustained in the two tides, amounted to £5000.

The cause of this failure may justly be ascribed to the great slope and the low parapet, by which the sea was thrown bodily upon the roadway, the pitching of which first gave way; a portion of the hearting then followed; afterwards the front wall fell, until at length all support was removed from the pitching stones of the slope, and they also were carried away.

In order to prevent such an occurrence in future, a wall of large rough stones was built under the parapet, as shewn on the cross section of the south pier; the roadway pitching was, in addition, wedged firmly with fir wedges, on which cills of 1½ inch boards, going along the roadway, were spiked down at in-

tervals of 10 inches apart; on these cills, boards, 1 inch in thickness, were fixed and closely joined together, the outer ends laying to the foot of the parapet, while the inner ends reached half way over the coping of the front wall, so that the sea, in falling from the parapet, was not allowed to touch the pitching.

Early in the spring of 1828, preparations were made for rebuilding the work which had been thrown down; so much difficulty was experienced in the erection of machinery and clearing out the old materials, that it was found easier to quarry most of the stones afresh, than to drag out of deep water the stones which had been carried thither by the sea.

The machinery used by the author, consisted of four jib cranes, which were set in strong frames of timber, of sufficient height to build the front wall and the parapet. There were also two radiating beam-cranes, each 110 feet in length, working upon rails supported by posts built into the slope, moved round by a small rope tackle on each side, and having a travelling carriage on each for the crane chain. These cranes took in the whole range of slope, without being moved, and were very efficient.

The stones used for the construction, were of hard quality and naturally well shaped for the work; they varied in dimensions from 3 feet to 20 feet in length, by 3 feet to eight feet in breadth, and 8 inches to 15 inches in thickness. In the slope they were set on edge, and the courses were placed diagonally; in the front wall they were laid flat, the beds being perpendicular to the line of face.

In laying the foundations under water, the two-crane lighter was particularly useful, one crane being used for clearing away the sand, by means of a bag and spoon, while the other set the stones in their places. The foundation course of the slope consisted of large blocks of stone, each from 15 tons to 20 tons weight, and it was for floating these stones that the author first used the casks, of which he presented the description to the Institution. (See p. 428.)

In the month of September in the same year, the whole length of 120 feet of pier was completed, and since that period not a single stone has been removed by the sea.

The parapet of the south pier being only 6 feet in height, with a flat slope on the outside, was but ill adapted for affording a shelter on the inside of the pier in storms: in fact, the sea broke over it at high water as over a half-tide rock. After many representations on the part of the author, it was resolved to raise the parapet to the present height of 14 feet, which was done in the following year. The necessity for this appears from the fact, that even now, during storms, the spray is carried a distance of 100 feet, after passing over the parapet. If the slope had been less, the force of the receding wave would have been increased, so as to counteract the force of the wave, on meeting it, before touching the slope: at its present inclination of 3 to 1, the re-

ceding wave only adds to the bulk and violence of the approaching wave.

During the year 1830, great progress was made with the north pier and the interior works. The harbour was excavated to the level of low water of ordinary spring tides, and the material obtained was used in the hearting of the jetty. A very slight batter was given to the back wall, because the sea, in running along the face of the pier, at an angle of 45° , exerted but little force against it.

The south harbour was completed in 1830, and cost £20,900, including the opening connecting it with the north harbour, closing the old entrance, and all repairs for three years after its completion; the quarry was near, and labour was cheap, or nearly double the amount would have been expended.

The effect of the north pier, in contracting the bay, has led to a large accumulation of sand on the north side of the river, which is a proof, in the author's opinion, that if the sea be carried past the entrance of any harbour, the sand is, necessarily, carried past with it; in this case, great change was produced by the junction of the two harbours. The north harbour was rendered much more convenient and safe, and less liable to be sanded up; it was soon after deepened, and the pitching of its roadways partially relaid.

It is still to be regretted, that in stormy weather the south harbour does not afford proper shelter, and considering that it is surrounded (excepting a slope of 300 feet in length), by perpendicular walls, which add to the recoil of the sea within, this is not to be wondered at. Besides this evil, it is liable to become partially sanded up, probably from the effects of the river running against the projection of the south pier, beyond the projection of the north pier; the removal of this sand has been attended with some cost and trouble.

Pulteney-Town covers a large space of ground, and is composed of neatly built houses, two and three stories in height; the population is estimated at 3,200, entirely sprung up in thirty-eight years.

Ship and boat-building, and the rope and sail-cloth manufactures are extensively carried on, but the fishery forms the staple trade of the place, so that fish-curing and cooper-work are carried on to a great extent. The average quantity of herrings caught annually, exceeds 60,000 barrels; and about 12,000 persons, chiefly strangers, are employed during the fishing season, which extends usually from the middle of July to the early part of September: about 600 fishing boats, each of 20 tons burthen, enter and depart from Pulteney-Town when the weather permits. The shipping frequenting the port in 1843, amounted to 53,952 register tons, of which 5,460 tons were in the foreign trade.

An increase of harbour space, and of depth of water, has been so eagerly sought after, recently, that the British Fisheries

Society applied to the author for a plan, comprising a low-water harbour, which should be altogether free from sand, the entrance being in deep water and away from the influence of the river, while the pier heads should be so placed as to throw the sand past them, along with the sea, and at the same time be easy of access, which would be important for a refuge harbour. A slope of 750 feet in length, with an inclination of 1 in 12, for expending the force of the sea, would be required. The south harbour also required to be freed from sand, and deepened. This plan is shewn in fig. 1, and an Act of Parliament has recently been obtained for its execution.

The paper is illustrated by two drawings, giving the general plan of the harbour, with the proposed improvements, and the sections of the pier walls, with the sea slopes and the method of constructing them.

“Description of the Casks used for floating large stones, to construct Sea Walls in deep water.”

By James Bremner, M. Inst. C.E.

The ordinary mode of conveying stones for harbour work, is by means of two large boats, with baulks of timber lashed across them, from which rope tackles are suspended. These tackles are hooked on to ‘lewises’ inserted into the stones, and tightened at low water. When the tide flows, the stone floats, and it can be conveyed to the spot where it is intended to be laid. Stones weighing 40 tons each, have been thus transported several miles, without difficulty, in good weather; but it has been found, that the boats were soon strained, and became leaky, and on an exposed coast, when bad weather came on, they were liable to be destroyed; the author therefore devised the plan described in the paper, as a substitute for the united boats.

About eight years ago, the author was consulted as to the improvement of the harbour of Banff, and the repairs of the sea slope of the north pier, the foundations of which had partially failed. He found, that the previous attempts at preventing the destruction of the pier, by laying down stones of from 2 to 4 tons in weight, brought from a quarry in the neighbourhood, had been quite ineffectual, as such materials could not withstand the force of the waves. He had observed along the shore, at several miles westward of the harbour, in almost inaccessible situations, ranges of large rough stones of hard quality, weighing from 25 to 40 tons each, and he determined to use them for the repairs of the work. It would have been almost impossible to get the boats near them, so he resolved to use casks for the purpose, as he had formerly done, under somewhat similar circumstances, at Pulteney-town harbour.

There was but little novelty in the construction of the casks,

which were of fir timber; the ends had each two cross boards inside, with four props fitted between them, and there was a slip feather at each joining of the end boards: there were also interior hoops of timber, strutted from the centre by spokes, like those of a wheel, in the situation of the chains by which the stone was borne; the whole was hooped outwardly with iron, and made in the strongest manner, consistent with lightness, to resist external pressure.

Where any of the stones were under low water, wooden frames were used in boring the holes for inserting the lewis. The casks were towed to the spot, and at low water were attached to the stone, by means of chains passing through the lewis rings and over the casks. At the top of each cask, the spindle of one end of the chain was passed through the ring of the other, pulled tight, and fastened backward, by a small hempen line, to the chain. On the flowing of the tide, which rose at that spot from 10 feet to 15 feet, the casks and the stone floated together, and were towed away by means of a boat; the stone was then moored over the spot where it was intended to be laid, and at about half ebb, by means of a long-handled knife, the small lines, by which the chains were attached, were cut; the casks rose to the surface, and the stone, being guided into its position by boat-hooks, fell into its destined spot: the chains were then drawn away, and the casks were again fixed on, at low water, to the next stone to be floated.

The advantages gained by these means were obvious. The coast was too rugged and dangerous to admit of a crane-lighter being used, and if it could have been worked, the stones were much too heavy to be lifted on deck, and even then there would have been some difficulty in moving a lighter such a distance. The stone displacing its own bulk of water, left not quite 13 cwt. per ton for the casks to lift, the specific weight of water, and of the stone, being respectively 36 cubic feet and 13 cubic feet to the ton. Each cask weighed 25 cwt., and displaced 445 cubic feet of water; so that two casks lifted a gross weight of $34\frac{1}{2}$ tons of stone, the displacement of water caused by which was equivalent to lifting $12\frac{1}{4}$ tons. When rough weather came on, the casks were easily disengaged, and were rolled to above high-water mark, without the least injury. Even in a heavy surf, stones have been buoyed out, by means of a long towing-line fastened to the casks. The strength and tightness of the casks were very remarkable; after being used for 24 hours, scarcely a gallon of water was found in each cask. This must, in some measure, be attributed to the swelling of the wood.

Four casks were used, and with them a length of 400 feet of the foundation was effectually secured, in the course of a few months, and not a stone has since been removed.

To ensure still further the stability of the stones when laid, the author proposed to have a chain cable passed through a lewis in

each stone, and permanently fastened to the pier, so as to connect the whole together.

The application of these casks has not been confined to floating stones. In Banff, as well as in Macduff Harbour, great inconvenience was felt from the want of a sufficient depth of water. In case of a vessel being fully loaded up in the harbour, and the depth of water being insufficient, four of these casks were attached, by means of chains previously passed under the vessel's keel: with the flowing tide, a lift equal to 44 tons was given by the casks, which were afterwards easily disengaged, when the vessel was outside, in deep water. To a vessel of 100 tons register, a deficiency of 15 inches in her draught of water has been supplied by these means, the want of which water would otherwise have occasioned detention and loss.

The author believes, that casks would be found equally efficacious in removing stones from the beds of rivers, &c., as from dangerous and exposed parts of the sea-coast.

The cost of each of the casks was £8, and they were not at all injured by the work they were used upon. The charge for labour, in making lewis holes, fixing on the casks, and removing the stones 3 miles, was only 1s. 6d. per ton, which included lowering them into their proper places and towing back the casks; in short, every expense, except that of finding casks and lewises.

The lewises used were of the simplest kind; the shank part inserted was 2 inches in diameter at the bottom, tapering to 1½ inch at the top, where a ring was welded into an eye; into this ring, the chains were fastened, before letting in the lewis, which was done by means of two guide rods of iron, close to the mouth of the jumper-hole; the wedge was then inserted, by means of a pair of long-handled tongs; a punch bar of iron being set on its top to hammer it down. Although the lewis-holes were perfectly cylindrical, not a single instance occurred of the lewis being drawn out, even when raising the heaviest stones.

The author thinks, that the slope of Banff Harbour, which is 3 horizontal to 1 perpendicular, is much too flat, as no superincumbent weight being added to the foundation course (on which the whole slope abutted), the stones were liable to be moved outward, by the heavy recoil of the receding waves, acting at low water on their surface and on the inner bed joints. This was the case with the new pier at Banff, which was designed by the late Mr. Telford, and has also been found, in many other harbours, to be cause of constant outlay for repairs. The author suggests, that a curved slope of 1 to 1, reckoning from the top of the parapet to the foundation, should be used, and he has found that even a less slope than 1 to 1 answers very well, even in very exposed situations, if the foundation can be let into the rock.

The paper is illustrated by a drawing, shewing the construction and the mode of using the casks, and by marginal sketches of the lewis and other details.

A Model was exhibited of Faram's Railway Switch.

The object of this invention was explained to be, that by means of an apparatus attached to the locomotive engine, and under the command of the driver, the switches of the railway should be moved into such positions, as would be necessary to divert the train into the required direction, and thus render it unnecessary to have persons in attendance, to place the switches correctly for the next coming train. In the arrangements of this apparatus, care was taken to avoid too sudden contact between the switches and the projecting arm which caused the movement. It was stated, that if any objection existed to placing the control of the switches under the engine-driver, that part of the apparatus could be suppressed, and the switches could be worked by hand from the side of the railway as at present; but Mr. Faram stated that system to be less useful and certain than his plan.

The description of the switches was illustrated by three drawings.

March 19th, 1844.

The PRESIDENT in the Chair.

“Description of the formation of the Town-lands of Musselburgh, on the Firth of Forth.” By James Hay.

THE author states, that the delta of low alluvial land at the mouth of the river Esk, which comprehends the town lands of Musselburgh, to the extent of at least 400 acres, has been gained from the sea, in the space of about three hundred years, by the gradual operations of nature unassisted by art. If an excavation is made to the depth of a few feet, in ground that has not been previously disturbed, gravel and a few shells are found, the latter not fossilized, but in the same state in which they are found upon the beach at this time; and in cutting a drain to a depth of 7 feet in this deposit, at a quarter of a mile from the sea, the author found a piece of wrought-iron, which was surrounded by a concretion of shells and gravel, clearly proving that the sea had recently been there. He also mentions several facts, from ancient charters and leases, shewing that the spot, where the present town-lands of Musselburgh exist, must formerly have been beneath the level of the sea.

The causes which contribute towards producing these changes are, that the river Esk, when swollen by rain, brings down with its floods the detritus of the hills through which it passes, which, with the soil washed from the banks of the low-lands, is arrested, when it meets the tide, and is thrown on the beach; then, by the action of the high north winds, the sand is carried up from the gravel, and raises the land several feet above the level of the sea, and in some places as much as 12 feet.

Another cause is, that along the Firth of Forth, and particu-

larly between Leith and Newhaven, the sea has made great encroachments, and about a mile west of Musselburgh harbour, many acres of land have been swept away, the lighter portions of which are carried eastward by a current setting in that direction, and are lodged near the mouth of the Esk.

The communication is illustrated by two small sketches, shewing the several lines of high-water at various dates, and a section of the strata of the new formation.

“Description of the Hydraulic Traversing Frame, at the Bristol terminus of the Great Western Railway.” By Arthur John Dodson, Assoc. Inst. C.E.

The object of this machine is to transport the railway carriages from the arrival side of the terminus to the departure side, or to any one of the several intermediate lines, without the use of turn-tables, which cannot always be conveniently or safely introduced, and also without any intersection or derangement of the rails.

The apparatus consists of a wrought-iron frame, connected by cross and diagonal pieces, and supported upon eight cast-iron wheels. At the four corners of the frame, cast-iron hydraulic presses are fixed, and at one end of it, two force-pumps are placed, connected with the presses by copper pipes and gun-metal nozzles. Upon the wrought-iron plungers of the four presses, two additional frames rest; these are attached to the lower frame, by four sets of parallel-motion bars, to ensure their rising perpendicularly.

The action of the machine is described as follows:—

An opening being made in the train, the apparatus is pushed on to the line of rails, and the carriage required to be moved is placed over it when the frame is quite down. As soon as the carriage is brought directly over the apparatus, a man works the larger pump acting upon the four hydraulic presses, which raise the frames until they are in contact with the axles of the carriage wheels; the smaller pump is then worked, until the flanges of the carriage wheels are clear of the rails. The whole apparatus, with the carriage suspended upon it, is then easily transported to any of the lines of rails, and by unscrewing the stopper, which allows the water to flow back from the presses into the cistern, the carriage is lowered on to the rails; it is then pushed back, and the apparatus is rolled over, ready for re-commencing the operation, the whole transit not having occupied more than a minute and a half.

The communication is accompanied by three drawings, giving a general view of the traversing frame, with the attached pumps, details of the construction of the pumps, with their frame-work, and a view of the machine raising a first-class carriage.

Mr. Dodson stated, in answer to questions from the President, that this hydraulic traversing frame had cost about £220 ; that it was the only one of the kind at present in use on the Great Western Railway ; but that, in consequence of its action being so much approved, several others were expected to be erected.

Mr. Brunel said, that the machine in question was made by Mr. A. Napier ; it was extremely well constructed, and he intended using others of the same kind. He expected they would be less expensive than the one described, which was the first that had been made.

“Account of the Land-slip in Ashley Cutting, on the line of the Great Western Railway.”

By John Geale Thomson, Grad. Inst. C.E.

The object of the author of this paper is to shew, that the land-slip which he describes, had its origin in a peculiarity of the geological position, and not in the nature of the ground in which it occurred.

To explain this view, the formation of the oolitic district, so far as it relates to engineering purposes, is described generally, and a more particular account is given of the valley of the Box brook, in which this slip took place.

The Ashley cutting is situated about 5 miles on the London side of Bath, at the base of Kingsdown hill, the level of the rails being about 23 feet above the level of the Box brook.

In Mr. Lonsdale's account of the oolitic district of Bath*, the valley of the Box brook is styled, a denuded valley of the lias, or, in other words, that the action of denudation has ploughed into, but not through, the lias ; whereas it has completely eroded the superjacent strata. The valley is one of the two plains, which separate the parallel ridge of the great or upper oolite, which occupies, with few exceptions, the summits of the hills in that part of the country. The extreme height of the range of hills at Lansdown, its western extremity, is about 813 feet above the level of the sea. The summit of Kingsdown hill, behind the cutting, is rather higher than Box hill, over the tunnel ; and from the several heights given by the author, it appears, that the country slopes gradually from Kingsdown hill to the railway, at the rate of 1 in 11, exposing a slope of 4000 feet in length to the decomposing action of the atmosphere, and to the collection of water. From the appearances of this locality, and other observations, the author contends, that a considerable accumulation of drift from the high lands behind the cutting, had, in the course of time, settled at the base of the hill, whereby the original contour of the valley of denudation had been altered ; that this had

* Vide Trans. Geol. Soc. vol. iii. part 2.

been caused by the unremitting action of water and the atmosphere, smoothing down the projections, and filling up the cavities, which the unequal effect of water upon strata of different degrees of hardness, had left upon the slope ; and that the mass of loose stuff, through which the cutting was partly carried, was formed from the slope behind it, in the manner described, and was not part of the original stratification.

On the north side of the valley, the upper oolite was generally wanting, having been carried away, except from the tops of isolated hills, such as Banner Down and Lansdown, which lie between the sea and the southern and more continuous range. Owing to the slightness of the strike of the country towards Bradford, it is contended, that all the surface-water found its way down the slope of the hill, or the line of steeper descent, little or none being absorbed into the body of the hill ; that as even in winter very few streams were visible, the vast quantity of water discovered in the cutting, must have entered the surface above, and percolated the ground for a considerable distance, and at last found its way into the Box brook, whence it carried considerable quantities of sand and silt, causing the subsidences at the surface which were everywhere visible. In excavating the eastern part of the cutting, holes of 12 inches to 18 inches diameter were found in the loose ground ; these had been evidently formed by the action of water, which flowed from them in clear uninterrupted streams. That great changes of the surface had occurred, was further evident, from the circumstance of finding, at a depth of nearly 10 feet, two human skeletons, whose bones were scattered and rubbed, as if they had been carried thither by the settling of a semifluid mass.

Upwards of 1,500 yards of shafts and headings were driven, at an average cost of about thirty shillings per yard forward. The drift is stated to stand at present at a slope of 2 to 1, which is assumed by the author as a confirmation of his opinion, that the ground was radically favourable for railway operations, but that it was affected by local peculiarities, which it was originally impossible to have foreseen.

The necessity of attending to geology, as connected with engineering, is insisted upon, as the author contends that, in almost all instances, the actual surface of the country forms but a poor criterion for judging of its original formation. The paper concludes with an examination into the effects of water upon clay, when in the ground and under pressure, and when exposed to the action of the atmosphere. The author attributes the disintegration of the clay by water, in the latter case, solely to the degree of pressure it is subject to, and cites some instances which came under his observation, in support of this opinion.

The account embraces a record of the work, extending over a space of more than two years, so that it is impracticable, within the limits of an abstract, to give more than an outline of it.

The paper is illustrated by a drawing, shewing the plan and numerous sections of the cutting in all stages of the progress of the slip and of the works.

Mr. Lowe remarked, that the paper which had been read, shewed how intimately the science of geology was connected with that of civil engineering, and of what essential assistance its study was. This could not be too strongly insisted upon, and it was very desirable, that resident engineers on railways should communicate to the Institution plain but detailed accounts of the events which occurred daily under their notice, and which, when illustrated by drawings like that which accompanied Mr. Thomson's paper, would form invaluable records.

Mr. Sopwith said, that the detailed account given by Mr. Thomson, derived additional interest from the circumstance of its relating to the district, and to the same series of rocks, which first led to the examination and arrangement of the strata of the British Isles, by Mr. Smith, who had been justly named the father of geology.

The vast masses of drift, which frequently covered the regular stratification, had only recently become a subject of investigation; and Mr. Thomson had not only described the extent, nature, and effects of drift in this instance, but he had also investigated with care the sources whence it originated. This would often be found a study of practical value, as throwing a light on the nature of the material to be dealt with. Mr. Sopwith instanced the drift near the mouth of the river Tyne, which contained limestone brought from a distance of full thirty miles, and granite from more than seventy miles. The effect of masses of gravel, in displacing the stratified rocks, was also shewn on the banks of the river Tyne, where the front of a quay that was nearly perpendicular when built, was now, by the effects of the superincumbent gravel of a ballast-hill, in a nearly horizontal position. The fact, that the surface contour of a mass of drift, bore no relation to that of the harder rocks beneath, was now well known; and in the locality described by Mr. Thomson, rocks reposed, in what was called 'unconformable position,' upon the local strata. The paper just read, was a striking illustration of the value of the railway sections, lately collected and placed in the Museum of Economic Geology.

Mr. Slate said, that there were some remarkable deposits of drift in the Staffordshire coal-field. They had completely filled the spaces, which must have been left, when the great downthrows or faults occurred. Between Dudley and Birmingham, the coal and all the other strata had been thrown down vertically nearly 100 yards, and yet there was not any appearance of irregularity on the surface of the ground.

LIST OF REGISTRATIONS EFFECTED UNDER THE ACT FOR PROTECTING NEW AND ORIGINAL DESIGNS FOR ARTICLES OF UTILITY.

1844.

- Nov. 25. *Charles Millingen*, of 15, White Lion-street, Norton Falgate, for a parasol.
28. *James Wilson*, of 18, Old Bond-street, London, for a tailor's measuring instrument and drafting scale.
28. *Joseph Haynes*, of 14, Avenue-road, Regent's Park, for an apparatus for extracting corks.
28. *William Bridges*, of Croydon, for a railway carriage.
30. *Stephen Green*, of Prince's-street, Lambeth, for a design for having metal legs to a basket containing earthenware bottles.
- Dec. 4. *Joseph Daniel Davidge*, of 50, Rahere-street, Goswell-road, London, for a tubular wick candle.
4. *Alexander Coombs*, of 26, Denmark-street, St. Giles's, for a spring box.
4. *Frederick Farmer*, of Brighton, for a truss.
6. *James Kearsley*, of York, for a self-folding step for coaches and other carriages having doors.
7. *Herbert Room*, of Bull Ring, Birmingham, for an improved kitchener.
10. *Squire Cheavin*, of Donington, Boston, Lincolnshire, for a floating filter, to be attached to a pump.
12. *Isaac Julian*, of Old George's-street, Cork, for a scrowl-spring.
13. *William Henry Smith*, of Wellingborough, Northamptonshire, for the "Euknemida" boot, shoe, and gaiter fastening.
16. *William Tabberer*, Jun., of 4, Weaman-row, Birmingham, for a globe fastener for sashes, tables, &c.
18. *Messrs. Ratcliff*, of Birmingham, for a portable bed-warmer.
18. *Messrs. Ratcliff*, of Birmingham, for the royal bell cushion.
20. *John Robinson & Co.*, of 4, Nassau-place, Commercial-road, East, for a shirt.
23. *William Smith*, of Alnwick, Northumberland, for a sash suspension shield.
26. *Alexander Stiven*, of 12, London-road, Manchester, for an expanding boring tool.

List of Disclaimers
OF PARTS OF INVENTIONS AND
Amendments

MADE UNDER LORD BROUGHAM'S ACT.

Joseph Woods, of Bucklersbury, engineer,—memorandum of alteration of title of patent, dated 6th June, 1844, for “improvements in producing designs and copies, and in multiplying impressions, either of written or printed surfaces.” Filed 4th December, 1844.

Daniel Gooch, of Paddington-green,—disclaimer and memorandum of alteration to patent, dated 28th May, 1840, for “certain improvements in wheels and locomotive engines, to be used on railways.” Filed 5th December 1844.

George Wilson, of St. Martin's-court, St. Martin's-lane, stationer,—disclaimer to patent, dated 19th June, 1844, for “improvements in the cutting of paper for the manufacture of envelopes, and for other purposes.” Filed 20th December, 1844.

List of Patents

*That have passed the Great Seal of IRELAND, to the 17th of
December, 1844, inclusive.*

To William Mackie, of No. 141, Lower Baggot-street, Dublin, builder, for a new mode of taking out sashes of windows, for the purpose of cleaning, glazing, and repairing, without removing slips or stops of sash-frames, and differing from any other mode now in use.—Sealed 21st November.

Robert Ferguson and John Clarke, both of the city of Glasgow, in the county of Lanark, for an improvement in printing and calendering.—Sealed 25th November.

George Ferguson Wilson, of Belmont, Vauxhall, in the county of Surrey, Gent., George Gwynne, of Prince's-street, Cavendish-square, in the county of Middlesex, Gent., and James Pillars Wilson, of Belmont, aforesaid, Gent., for improvements in treating fatty and oily matters, and in the manufacture of candles and night lights.—Sealed 26th November.

- Moses Poole, of Serle-street, London, Gent., for improvements in machinery for emptying privies and cesspools.—Sealed 7th December.
- William Henry Ritchie, of Lincoln's-inn, in the county of Middlesex, Gent., for improvements in obtaining copper from ores.—Sealed 7th December.
- William Clarke, of Nottingham, lace manufacturer, for improvements in machinery for the manufacturing of ornamented bobbin net or twist lace.—Sealed 13th December.
- James Nasmyth, of Patricroft, in the county of Lancaster, civil engineer, for certain improvements in machinery or apparatus for hewing, dressing, splitting, breaking, stamping, crushing, and pressing, stone or other materials.—Sealed 13th December.

List of Patents

Granted for SCOTLAND, subsequent to November 22nd, 1844.

- To Josias Christopher Gamble, of St. Helens, Lancashire, manufacturing chemist, for improvements in the manufacture of sulphuric acid.—Sealed 25th November.
- William Johnson, of Bury, Lancashire, agent, for improvements in machinery or apparatus for preparing cotton, wool, flax, and other fibrous substances.—Sealed 25th November.
- Ebenezer May Dorr, of Ludgate-hill, London, for improvements in the manufacture of horse-shoe nails,—being a foreign communication and partly his own invention.—Sealed 25th November.
- Robert William Sievier, of Henrietta-street, Cavendish-square, London, for certain improvements in looms for weaving, and in the mode or method of producing plain or figured goods or fabrics.—Sealed 26th November.
- James Nasmyth, of Patricroft, in the county of Lancaster, civil engineer, for certain improvements in machinery or apparatus for hewing, dressing, splitting, breaking, stamping, crushing, and pressing, stone or other materials.—Sealed 27th November.
- David Auld, of Dalmarnock Road, engineer, and Andrew Auld, of No. 78, West-street, Tonderton, engineer, both in Glasgow, for an improved method or methods of regulating the pressure and generation of steam in steam-boilers and generators.—Sealed 29th November.

- Charles & Watterson, of the firm of MacGuire, Watterson, Co., of Manchester, soap manufacturers, for certain improvements in the manufacture of soap.—Sealed 9th December.
- Louis Joseph Wallerand, of Basing-lane, London, merchant, for improvements in dyeing or staining various kinds of fabrics,—being a foreign communication.—Sealed 16th December.
- Alexander Turnbull, of 48, Russell-square, London, Doctor of Medicine, for a new mode or method of more expeditiously and effectually tanning hides and skins, and of extracting and separating the catechuic acid from the tannin acid, in the catecha or terra japonica used in tanning.—Sealed 18th December.
- Henry Cartwright, of the Dean, near Brosely, in the county of Salop, farmer, for certain improvements in the construction of paddle-wheels.—Sealed 20th December.

New Patents

SEALED IN ENGLAND.

1844.

- To John Barker Anderson, of Great Suffolk-street, Surrey, for improvements in the manufacture of soap. Sealed 25th November—6 months for inrolment.
- William Clarke, of Nottingham, lace manufacturer, for improvements in the manufacture of ornamental lace or net. Sealed 25th November—6 months for inrolment.
- Benjamin Ballie, of Henry-street, Middlesex, glazier, for improvements in regulating the ventilation of buildings. Sealed 25th November—6 months for inrolment.
- Ebenezer May Dorr, of Ludgate-hill, Gent., for improvements in the manufacture of horse-shoe nails,—being partly a communication. Sealed 25th November—6 months for inrolment.
- John William Buckle Reynolds, of Lymington, engineer, for improvements in obtaining motive power for working locomotive carriages and other machinery. Sealed 25th November—6 months for inrolment.
- George Millichap, of Birmingham, for improvements in the construction of axletrees. Sealed 25th November—6 months for inrolment.

- William Oxley English, of Kingston-upon-Hull, distiller, for improvements in the distilling of turpentine and tar, and rectifying volatile spirits and oils. Sealed 25th November—6 months for enrolment.
- William Alsop, of Tabernacle-walk, Middlesex, weaver, and Thomas Forster, of Streatham, manufacturer of India-rubber fabrics, for improvements in the manufacture of elastic fabrics, and in making articles from elastic fabrics, and for weaving fabrics for the driving-bands of machinery, and other uses. Sealed 25th November—6 months for enrolment.
- Narcisse Leroy, of Paris, merchant, for improvements in covering the tops of bottles, jars, and other vessels,—being a communication. Sealed 28th November—6 months for enrolment.
- Louis Antoine Ritterbandt, of Gerard-street, Soho, Doctor of Medicine, for certain improvements in preventing and removing incrustation in steam-boilers and steam-generators. Sealed 2nd December—6 months for enrolment.
- James Wigglesworth, of Bedford-street, Strand, chemist, for an improvement or improvements in steel pens. Sealed 2nd December—6 months for enrolment.
- William Henry James, of Clement's-lane, civil engineer, for certain improvements in carriages for the conveyance of passengers and goods, and in the means of working the same. Sealed 2nd December—6 months for enrolment.
- James Winter, Sen., of 101, Wardour-street, Soho, upholsterer, James Winter, Jun., of the same place, upholsterer, and William Lane, of Bedford-place, Russell-square, Gent., for an improved scaffold or mode of scaffolding, applicable also as a fire-escape, for life and property. Sealed 2nd December—6 months for enrolment.
- James Nasmyth, of Patricroft, Lancashire, civil engineer, for certain improvements in machinery or apparatus for hewing, dressing, splitting, breaking, stamping, crushing, and pressing, stone or other materials. Sealed 2nd December—6 months for enrolment.
- René Joseph Le Comte de Colombier, of Chancery-lane, for improvements in machinery for splitting and cutting skins and hides. Sealed 2nd December—6 months for enrolment.
- John Jeremiah Rubery, of Birmingham, umbrella furniture manufacturer, for improvements in the manufacture of umbrellas and parasols. Sealed 2nd December—6 months for enrolment.

- Josias Christopher Gamble, of St. Helens, in the county of Lancaster, manufacturing chemist, for improvements in the manufacture of sulphuric acid. Sealed 4th December—6 months for enrolment.
- Benjamin Seebohm, of Horton Grange, Yorkshire, merchant, for an improved mode of manufacturing certain descriptions of chains. Sealed 4th December—6 months for enrolment.
- John Ronald, of Glasgow, merchant, for an apparatus for boiling sugar cane, juice, and other liquids. Sealed 5th December—6 months for enrolment.
- John Ryan, of Liverpool-street, London, surgeon, for certain improvements applicable to, or in the construction of, casks, barrels, or other vessels, intended to contain wine, beer, fermented liquors, or other liquids or substances, which are liable to fermentation or decomposition from exposure to the action of the atmosphere. Sealed 7th December—6 months for enrolment.
- James Smith, of the Cross Keys Hotel, Wood-street, London, engineer, for improvements in printing or ornamenting various fabrics. Sealed 7th December—6 months for enrolment.
- William Wood, of High Holborn, manufacturer, for improvements in printing, dyeing, staining, or producing marks or patterns in or upon woven, felted, or other fabrics. Sealed 7th December—6 months for enrolment.
- Thomas Metcalfe, of Eaton-square, Pimlico, brush maker, for improvements in the manufacture of brooms, brushes, or other similar articles. Sealed 7th December—6 months for enrolment.
- Alphonse le Mire de Normandy, of Dalston, Middlesex, Gent., for improvements in purifying lac, and in converting lac into shellac. Sealed 7th December—6 months for enrolment.
- John Fisher the younger, of Radford Works, Nottingham, Gent., and James Gibbons, of New Radford, machinist, for certain improvements in the manufacture of figured or ornamented lace or net, and other fabrics. Sealed 7th December—6 months for enrolment.
- William Willcocks Sleigh, of St. James's-square, M.D., for the hydro-mechanic apparatus, which, by a certain combination of hydraulic and mechanical apparatus, on well-known philosophical principles, is intended to supersede the use of fire and steam in working and propelling all kinds of machinery and engines. Sealed 7th December—6 months for enrolment.

Joseph Weiger, of Vienna, doctor of medicine and surgeon-dentist, for improvements in the amalgamation, alloying, and soldering of certain metals. Sealed 12th December—6 months for enrolment.

Charles Louis Felix Franchot, of Paris, engineer, for improvements in engines to be worked by air or gases. Sealed 12th December—6 months for enrolment.

William Kenworthy, of Blackburn, Lancashire, cotton spinner, for improvements in looms for weaving. Sealed 12th December—6 months for enrolment.

William Malins, of Mansion-house-place, London, iron-master, for improvements in constructing roofs and other parts of buildings, of iron or other metals, and in the preparation of the materials of which the same are, or may be, constructed. Sealed 12th December—6 months for enrolment.

Sebastian Mercier, of Paris, manufacturer of piano-fortes, for improvements in piano-fortes. Sealed 12th December—6 months for enrolment.

Robert Heath, the younger, of Kidsgrove, Staffordshire, coal agent, for improvements in heating ovens and kilns used in the manufacture of china, bricks, tiles, and other articles of earthenware. Sealed 12th December—6 months for enrolment.

Joseph Lockett, of Manchester, engraver, for improvements in apparatus for preparing to be engraved or turned, such copper or other metal cylinders, or rollers, as are to be used for printing or embossing, or calendering calico or other fabrics. Sealed 12th December—6 months for enrolment.

John Perry, of Leicester, wool comb manufacturer, for improvements in combing wool. Sealed 12th December—6 months for enrolment.

Moses Poole, of London, Gent., for improvements in the construction of fids for ships' masts, and in the means of setting-up ships' rigging,—being a communication. Sealed 12th December—6 months for enrolment.

George Fergusson Wilson, of Belmont, Vauxhall, Gent., George Gwynne, of Prince's-street, Cavendish-square, Gent., and James Pillans Wilson, of Belmont, aforesaid, Gent., for improvements in treating fatty and oily matters, and in the manufacture of candles. Sealed 12th December—6 months for enrolment.

- Warren de la Rue, of Bunhill-row, Middlesex, manufacturer, for improvements in covering the surfaces of paper and other materials with color and other substances. Sealed 12th December—6 months for inrolment.
- Robert Walker, of St. Helen's, Lancashire, colliery agent and manager, for improvements in apparatus for riddling coals at collieries. Sealed 18th December—6 months for inrolment.
- Ralph Knowles Waller, of Manchester, candle-wick manufacturer, for improvements in the manufacture of platted wicks, and in the manufacture of candles. Sealed 18th December—6 months for inrolment.
- John Wheeley, of Stafford, manufacturer of iron, for improvements in the manufacture of iron spoons. Sealed 18th December—6 months for inrolment.
- Nathaniel Fortescue Taylor, of Vauxhall, engineer, for improvements in apparatus for measuring gas. Sealed 18th December—6 months for inrolment.
- Arthur Wall, of Bisterne-place, Poplar, surgeon, for certain improvements in the manufacture of steel, copper, and other metals. Sealed 18th December—6 months for inrolment.
- Edward Hammond Bentall, of Heybridge, Essex, iron-founder, for improvements in implements or apparatus for sowing or depositing seed or grain. Sealed 18th December—6 months for inrolment.
- James Thompson, of Cornwall-road, Lambeth, baker, for certain improvements in the preparation and application of various farinaceous products, and for machinery used in manufacturing the same. Sealed 20th December—6 months for inrolment.
- Benjamin Biram, of Wentworth, in the county of York, Gent., for certain improvements in oscillating engines, worked by steam, water, or other fluids, which are also applicable to the raising or propelling of fluids. Sealed 21st December—6 months for inrolment.
- Charles Johnstone, of Southampton, engineer, for certain improved arrangements for raising ships' anchors, and other purposes. Sealed 21st December—6 months for inrolment.
-

CELESTIAL PHENOMENA FOR JANUARY, 1845.

D. H. M.	
1	Clock before the sun, 3m. 57s.
—	☽ rises Morn.
—	☽ passes mer. 5h. 31m. M.
—	☽ sets 11h. 1m. M.
3 21	☽ in ☐ or last quarter
10 16	☽ in the ascending node
2 9 34	♃'s first sat. will em.
16 2	♃ stationary
3 22 30	♃ in conj. with the ☽ diff. of dec. 2. 3. N.
5	Clock before the sun, 5m. 47s.
—	☽ rises 4h. 56m. M.
—	☽ passes mer. 9h. 9m. M.
—	☽ sets 1h. 19m. A.
6 7	♃'s second sat. will em.
13 2	♀ in conj. with the ☽ diff. of dec 0. 28. N.
16 52	Ceres in conj. with the ☉
23 53	♃ in Perihelion
6 17	☽ in Perigee
7	♃ greatest hel. lat. S.
8 7 13	Ecliptic conj. or ● new moon
9 41	♃ in conj. with the ☽ diff. of dec. 2. L. S.
9 4 43	♃ in conj. with the ☽ diff. of dec. 5. 30. S.
6 20	♃'s third sat. will em.
10	Clock before the sun, 7m. 55s.
—	☽ rises 8h. 56m. M.
—	☽ passes mer. 2h. 10m. A.
—	☽ sets 7h. 36m. A.
	Occul. c1 Capri, im. 5h. 37m. em. 6h. 8m.
11 5 59	♃'s first sat. will em.
12 0 38	♃ in inf. conj. with the ☉
8 44	♃'s second sat. will em.
23 46	♃ in conj. with the ☽ diff. of dec. 6. 18. S.
	Occul. ♀2 Piscium, im. 4h. 36m. em. 5h. 49m.
	Occul. ♀1 Piscium, im. 4h. 40m. em. 5h. 44m.
	Occul. 16 Piscium, im. 9h. 57m. em. 10h. 48m
13 6 27	♃ in conj. with the ☽ diff. of dec. 5. 23. S.
17 46	♃ in conj. with Ceres, diff. of dec. 6. 58. N.
15 8 51	☽ in ☐ or first quarter
16 7 15	♃ greatest hel. lat. N.
40	♃'s third sat. will im.
	Occul. ♀ Arietis, im. 8h. 53m. em. 9h. 27m.

D. H. M.	
	Occul. ♀3 Arietis, im. 12h. 47m. em. 13h. 43m.
17	Mercury R. A. 19h. 9m. dec. 19. 0. S.
—	Venus R. A. 17h. 51m. dec. 22. 35. S.
—	Mars R. A. 15h. 43m. dec. 19. 10. S.
—	Vesta R. A. 22h. 43m. dec. 13. 43. S.
—	Juno R. A. 9h. 50m. dec. 0. 42. N.
—	Pallas R. A. 18h. 49m. dec. 3. 27. N.
—	Ceres R. A. 19h. 30m. dec. 25. 33. S.
—	Jupiter R. A. 0h. 0m. dec. 1. 16. S.
—	Saturn R. A. 20h. 43m. dec. 18. 51. S.
—	Georg. R. A. 0h. 11m. dec. 0. 31. N.
—	Mercury passes mer. 23h. 14m.
—	Venus passes mer. 22h. 5m.
—	Mars passes mer. 19h. 55m.
—	Jupiter passes mer. 4h. 12m.
—	Saturn passes mer. 0h. 56m.
—	Georg. passes mer. 4h. 24m.
18 7 54	♃'s first sat. will em.
22	☽ in Apogee
20	Clock before the sun, 11m. 25s.
—	☽ rises 1h. 53m. A.
—	☽ passes mer. 10h. 4m. A.
—	☽ sets 5h. 28m. A.
22 12 38	♃ in conj. with Pallas, diff. of dec. 23. 31. S.
23	Occul. α1 Cancri, im. 16h. 53m. em. 17h. 56m.
23 2 20	Ecliptic oppo. or ○ new moon
6 33	♃ stationary
25	Clock before the sun, 12m. 42s.
—	☽ rises 7h. 16m. A.
—	☽ passes mer. 1h. 13m. M.
—	☽ sets 8h. 6m. M.
29 4 25	♃ in conj. with the ☉
11 13	♃ in conj. with Pallas
20	Clock before the sun, 13m. 39s.
—	☽ rises 0h. 7m. M.
—	☽ passes mer. 5h. 7m. M.
—	☽ sets 9h. 59m. M.
31 1 56	☽ in ☐ or last quarter
7 2	♀ in conj. with Pallas

J. LEWTHWAITE, Rotherhithe.

INDEX TO VOL. XXV.

[CONJOINED SERIES.]

	Page		Page
Adjudications, Scientific,—		Axle-boxes, improvements in,	
—, Stephens v. D. and		Parlby's patent.....	25
W. Felt.....	41	—, and in lubricating the	
—, Russell v. Ledsam		same, Newton's patent	27
and others.....	44	Axles, improvements in manu-	
—, Bunnett and another		facturing, Hill's patent	317
v. Smith	137	Barreswil's method of ascertain-	
—, Stead v. Williams		ing the quantity of crystal-	
and others.....	140	lizable sugar contained in sac-	
—, Bentley v. Fleming		charine substances	345
—, Crosskill v. Grounsell		Baths, improvements in, Ha-	
—, Welch and Marget-		zard's patent.....	395
son v. May	338	Bearings of machinery, im-	
—, Wolferstan v. Warner		proved alloy for making the,	
—, Bentley v. Fleming..		Fenton's patent	402
—, Woodcroft v. Reyner		—, and in lubricating the	
and another	413	same, Newton's patent.....	27
—, Bentley v. Carver ..	414	Beaverteens, rendering them	
—, The Queen v. Newton		repellent to water and mil-	
—, Mangnall and ano-		dew, Townend's patent	40
ther v. McAlpine.....	417	Berzelius' Report upon improve-	
Alloys of metals, improvements		ments in chemistry, extracts	
in the manufacture of, Fen-		from	210, 285
ton's patent	402	Black-lead powder, improve-	
—, Hood's patent..		ments in solidifying, Brocke-	
—, Kneller's patent		don's patent	13
.....	187	Boettger's improvements in	
Alterations or Amendments of		coating metals with nickel and	
Specifications and Titles to		platina by electro-deposition	
Patents, list of	147, 293, 437	Bolt rings or washers, improve-	
Alum, improvements in the		ments in the manufacture of,	
manufacture of, Turner's pa-		Lenox and Jones' patent...	320
tent	249	Boots and shoes, improvements	
American Patents, for improve-		in cementing leather to pro-	
ments in door locks, platform		duce, Austin's patent	17
spring-scales, looms, beehives,		—, improvements in manu-	
brick machines, stoves, water-		facturing, Wright and	
proofing leather, flax and		Wright's patent	247
hemp breakers, pianofortes,		Brazil, article on the patent	
preparing tobacco for pack-		laws of	279
ing, shaving shingles	407	Bretthauer's process of gilding	
Ammonia, improvements in		fabrics	348
manufacturing salts of, Tur-		Bricks, improvements in mak-	
ner's patent	263	ing, Denton's patent	393
—, Watson's patent		—, Grimsley's patent	157
.....	83	Bridges, improvements in cou-	
Apparel, an improved fastening		structing, Wood's patent...	267
for, Mills' patent	175	Brine, improvements in heat-	
—, Thomas' patent		ing, Sylvester's patent	189
—, improvements in		Buildings, improvements in ce-	
cleansing, Allaire's patent ..	322	menting materials for, Aus-	
—, improvements in		tin's patent	17
hooks and eyes for fastening,			
Wardroper's patent.....	310		

Page	Page		
Buildings, improvements in constructing roofs, and other parts of, Grimsley's patent ..	157	Cisterns, improvements in constructing slated, Martin's patent	311
—, improvements in constructing slated roofs and floors of, Martin's patent....	311	Civil Engineers, Report of the Transactions of the Institution of	125, 420
—, improvements in covering the roofs, walls, and other surfaces of, Galloway's patent	235	—, Telford and Walker premiums awarded and offered by the Institution of	341
—, improvements in ventilating, Grant's patent	397	Cleansing, an improved mixture for, Ward's patent	188
— in water, improvements in constructing, Bremner's patent	387	— garments, improvements in, Allaire's patent ..	322
Buttons, improvements in attaching to apparel, Mills' patent	175	Coal, culm, or cinders, improved apparatus for shipping, Day's patent	20
—, improvements in manufacturing, Sheldon's patent ..	237	Coating metals, improvements in, Morewood and Rogers' patent ..	37
Cameras, improvements in, Wolcott and Johnson's patent ..	330	Coffins, improvements in, Lindley's patent	108
Canal boats, a mode of connecting them together to form a train, Davies' patent	323	Compressing slivers and rovings into cans, Butterworth's patent	314
Candles and candlesticks, improvements in, and in apparatus for holding candles in candlesticks, Walker's patent	93	Cooling liquids, an improved refrigerator for, Masterman's patent	33
Candle-wicks, improvements in manufacturing, Connell's patent	179	Copper, an improvement in the manufacture of, Longmaid's patent	22
Cauvas, improvements in preparing it for painting, Galloway's patent	235	—, improved mixtures of metals to be used as substitutes for, Fento's patent ..	402
Carding engines, improvements in, Jackson's patent	7	Cyanogen, improvements in manufacturing the compounds of, Newton's patent	330
Cards for carding fibrous substances, improvements in, Kitson and Garthwaite's patent	124	—, Turner's patent	263
Caulking ships, improvements in preparing oakum for, Trent's patent	337	Daguerreotype pictures, mode of engraving, Claudet's patent	111
Celestial Phenomena, <u>72, 152, 224, 300, 372, 444</u>		—, improvements in obtaining, Wolcott and Johnson's patent	330
Cement, an improved, Marshall's patent	88	—, Page's mode of coloring	216
Cementing materials for building and other purposes, improvements in, Austin's patent ..	17	Designs, list of registrations effected under the new act, <u>64, 145, 218, 292, 365, 436</u>	
Chais, improvements in manufacturing, Haines and Haines' patent	166	Disclaimers of parts of Inventions and Titles to Patents, list of	147, 293, 437
—, Parkes' patent	240	Distilled liquors, improving the quality of, Hull's patent	121
Chemistry, recent improvements in, extracted from Berzelius' Report	210, 285	Draining purposes, improved machinery for moulding clay for, Denton's patent	393
		Dressing ores, improvements in, Troughton's patent	318
		Driving machinery, improved coupling gear for, Hick's patent	225

Page	Page
Drying apparel, improvements in, Allaire's patent	322
— fabrics, improved machinery for, Keely and Alliot's patent	373
Dyeing, improvements in, Poole's patent	183
Elastic fabrics, improvements in manufacturing, Bedell's patent	175
—, Newton's patent	252
—, Nickels and Nickels' patent	182
Electricity, improving the quality of fermented and distilled liquors by the action of, Hull's patent	121
—, Pring's mode of engraving upon or ornamenting metals by	136
Electro-deposition, Boettger's improvements in coating metals with nickel and platina by	354
—, improvements in coating fabrics with metal by, Schottlaender's patent	96
Engines, improvements in steam, Hick's patent	225
—, Shepherd's patent	101
—, Walther's patent	231
Fabrics, improved apparatus for sewing, Bostwick's patent	304
—, improved machinery for drying and stretching, Keely and Alliot's patent	373
—, improvements in coating with metal by electro-deposition, Schottlaender's patent	96
—, improvements in manufacturing elastic, Bedell's patent	175
—, Newton's patent	252
—, Nickels and Nickels' patent	182
—, plaited, Mertens' patent	123
—, rendering them repellent to water and mildew, Townend's patent	40
Farina of potatoes, improvements in extracting, Snell's patent	328
Fastening for gloves, and other parts of apparel, an improved, Mills' patent	175
— for portmanteaus, bags, boxes, books, and apparel, an improved, Thomas' patent	170
Fastening for dresses, improved hooks and eyes for, Ward-roper's patent	310
Fatty portions of animal and vegetable substances, improvements in extracting, Mollett and Bridgman's patent	401
Fermented liquors, improving the quality of, Hull's patent	121
Fire-engines, improvements in making hose for, Austin's patent	17
— proof composition, a, Marshall's patent	88
— roof, an improved, Grimsley's patent	157
Fires, improvements in extinguishing, Cameron's patent	24
—, improvements in preparing wood for lighting, Geeves' patent	248
Floor-cloth, a substitute for, Galloway's patent	235
Forging metals, improved machinery for, Nasmyth's patent	1
Fuel, improvements in manufacturing artificial, Dobree's patent	95
—, Marshall's patent	88
—, improvements in preparing peat for, Cobbold's patent	392
Furnaces or fire-places, improvements in, Detmold's patent	73
—, Holmes' patent	10
— used in the manufacture of glass, improvements in, Hartley's patent	185
Fustians, rendering them repellent to water and mildew, Townend's patent	40
Gas, improvements in purifying, Phillips' patent	39
Gilding fabrics, Bretthauer's process of	348
Glass, improvements in depositing metal upon it by electro-deposition, Schottlaender's patent	96
—, improvements in manufacturing, Hartley's patent	185
Gloves, an improved fastening for, Mills' patent	175
—, improvements in making, Walter's patent	91
Grinding grain, an improved mill for, Studley's patent	320
—, improvements in millstones for, Corcoran's patent	181

	Page		Page
Harbours, improvements in constructing and cleansing, Bremner's patent.....	387	Light-houses, improvements in constructing, Wood's patent	267
Hardtmuth's process of glazing pottery	213	Liquors, improving the quality of fermented and distilled, Hull's patent	121
Harpoons, improvements in, Lance's patent	162	Lithographic printing presses, improvements in, Nichol's patent	103
Hats, improvements in, Johnson's patent	394	Lozenges, improvements in manufacturing medicated, Brockedon's patent	13
Heating brine and other matters, improvements in, Sylvester's patent	189	Lubricating axles, and the bearings of machinery, improvements in, Newton's patent ..	27
Hooks and eyes for fastening apparel, improvements in, Wardroper's patent.....	310	Metallic powders and metal leaf, improvements in preparing materials used for fixing and protecting, Bessemer's patent	405
Hose for fire-engines, improvements in making, Austin's patent	17	Metals, Boettger's mode of coating with nickel and platina by electro-deposition	354
Hydrometer, an improved, Hick's patent	225	—, improvements in coating, Morewood and Rogers' patent	37
India-rubber, improvements in the manufacture of elastic fabrics by the introduction of, Bedell's patent.....	175	—, improvements in depositing upon fabrics, Schottlaender's patent	196
—, Nickels and Nickels' patent.....	182	—, improvements in furnaces for working, Detmold's patent	73
—, mode of applying, to produce plaited fabrics, Mertens' patent	123	—, improvements in manufacturing alloys of, Fenton's patent	402
—, preparing, and in manufacturing fabrics therewith, Newton's patent.....	252	—, Hood's patent....	306
Intonaco painting, a plastic composition for, Marshall's patent	88	—, Kneller's patent..	187
Iron, an improvement in manufacturing the peroxide of, Longmaid's patent	22	—, Pring's mode of engraving upon or ornamenting by electricity.....	136
—, improvements in furnaces used in the manufacture of, Detmold's patent.....	73	Meters for water and other fluids, improvements in, Hick's patent	225
Japanner's ware, improvements in the manufacture of, Sheldon's patent	237	Mildew, improvements in preserving cotton fabrics from, Townend's patent.....	40
Lace, improvements in manufacturing bobbin-net, Boden's patent	405	Mill for grinding grain, &c., an improved, Studley's patent..	320
Lamps, improvements in carrying off the products of combustion from, Grant's patent	397	Mill-stones, improvements in, Corcoran's patent.....	181
Leather, improvements in dressing, Wright's patent	118	Miner's lamp, mode of cleaning the.....	135
—, Wright and Wright's patent	247	Norway, article on the Patent Laws of.....	190
Life-preserver, a portable, Spicer's patent	242	Oakum for caulking ships and other vessels, improvements in preparing, Trent's patent	337
Light, improvements in producing, by percussion, Hay's patent	109	Oils, improvements in extracting from animal and vegetable substances, Mollett and Bridgman's patent	401

	Page		Page
Ores, improvements in dressing, Troughton's patent	318	Bridgman, J., and Mollett, R., for improvements in separating the fatty and oily from the membranous portions of animal and vegetable substances	401
Page's mode of coloring Daguerreotype pictures	216	Brockedon, W., for improvements in manufacturing pills and lozenges, and compressing black lead	13
Paint, a new, Bessemer's patent	405	Butterworth, J. H., for an improved apparatus for condensing the sliver in roving-cans, &c.	314
Painting, an improved ground for fresco and other styles of, Marshall's patent	88	Cameron, C., for improvements in extinguishing fires	24
—, improvements in preparing canvas for, Gallo-way's patent	235	Charlieu, A. D. de, for improvements in rails and wheels for railways	241
Paper, improvements in coating it with metal by electro-deposition, Schottlaender's patent	96	Claudet, A. F. J., for engraving Daguerreotype plates	111
Papier-maché, making articles in substitution of, Cobbold's patent	392	Cobbold, E., for improvements in preparing peat	392
—, Sheldon's patent	237	Connell, J., for improvements in candle-wicks	179
Patent Laws of different countries, article on the:—		Corcoran, B., for improved mill-stones	181
XIX. Sweden and Norway	190	Davies, H., for improvements in propelling vessels	323
XX. Brazil	279	Day, J. W., for an apparatus for facilitating the loading of vessels with coal, &c.	20
Patents, a new Act relative to the extension of	197	Denton, J. B., for machinery for moulding clay, &c.	393
—, list of new, granted in England, 68, 150, 221, 296, 368, 439		Detmold, J. A., for improvements in furnaces	73
—, in France	58, 143	Dobree, S., for improvements in manufacturing artificial fuel	95
—, in Ireland, 65, 147, 219, 294, 366, 437		Du Bochet, H., for improvements in piano-fortes	266
—, in Scotland, 66, 148, 220, 294, 366, 438		Fairbairn, W., for improvements in machinery for propelling vessels	166
—, reports of American	407	Fenton, J., for an improved alloy or mixture of metals	402
PATENTS, REPORTS OF RECENT.			
Allaire, R., for improvements in cleansing garments	322	Foulerton, R., for apparatus for facilitating the steering of vessels	81
Alliott, A., and Keely, J., for improved machinery for drying and stretching fabrics	373	Galloway, E., for the application of certain compositions to ship-building, paving, covering walls, &c.	235
Austin, H., for improvements in cementing materials together	17	Garthwaite, J., and Kitson, R., for improvements in wire cards, and in producing tow and yarn from hard waste	124
Bedells, C., for improvements in the manufacture of elastic fabrics	175	Geeves, W., for a method of preparing fire-wood	218
Bessemer, H., for a new pigment or paint, &c.	405	Grant, D., for apparatus for ventilating apartments	397
Boden, H., for an improvement in the manufacture of bobbin net lace	ib.		
Booth, H., for improvements in propelling vessels	18		
Bostwick, L., for a machine for sewing cloth or other materials	304		
Brenner, J., for improvements in constructing buildings in water, raising sunken vessels, &c.	387		

Page	Page		
Grimsley, T., for improvements in roofs and other parts of buildings, and in making bricks and tiles for the same	157	Lenox, G. W., and Jones, J., for improvements in washers, and in sheaves and shells for blocks	320
Haines, J. and R., for improvements in manufacturing flat chains	166	Lindley, J., for improvements in coffins	108
Hale, W., for improvements in rockets	15	Longmaid, W., for an improvement in the manufacture of copper, tin, zinc, and peroxide of iron	22
Hardman, L., for improved machinery for manufacturing sugar	153	Macdonough, M., for improved spinning machinery	243
Hardy, J., for improved machinery for welding tubes	301	Marshall, M. H., for an improved plastic composition	88
Hartley, J., for improvements in the manufacture of glass	185	Martin, T., for improvements in constructing slate roofs, tanks, pipes, &c.	311
Hay, W. J., for improvements in signal lights	109	Masterman, T., for an improved refrigerator	33
Hazard, R., for improvements in baths	395	Mertens, A., for improvements in manufacturing plaited fabrics	123
Hick, J., for improvements in steam-engines, in driving machinery, and in forcing and measuring water	225	Mills, W., for improvements in fastening gloves and other parts of apparel	175
Hill, E., for improvements in axles, shafts, and bars	317	Mollett, R., and Bridgman, J., for improvements in separating the fatty and oily from the membranous portions of animal and vegetable substances	401
Holmes, G., for improvements in furnaces or fire-places	10	Morewood, E., and Rogers, G., for improvements in coating metals	37
Hood, J. L., for improved alloys or mixtures of metals for ships' sheathing, bolts, &c.	306	Nasmyth, J., for improved machinery for driving piles and stamping metals	1
Hull, A. G., for a method of improving fermented and distilled liquors	121	Newton, A. V., for improvements in the manufacture of cyanogen and its compounds	380
Jackson, R. R., for improved carding and spinning machinery	7	——, W. E., for improvements in axle boxes and bearings of machinery	27
Johnson, A. R., for improvements in hats	394	——, —, for improvements in preparing India-rubber, and manufacturing fabrics therewith	252
——, J., and Wolcott, A. S., for improvements in photography	330	Nichol, W., for improved printing presses	103
Jones, J., and Lenox, G. W., for improvements in washers, and in sheaves and shells for blocks	320	Nickels, C. & B., for improvements in manufacturing elastic fabrics	182
Keely, J., and Alliot, A., for improved machinery for drying and stretching fabrics	373	Parkes, H. P., for improvements in manufacturing flat pitch-chains	240
Kitson, R., and Garthwaite, J., for improvements in wire cards, and in producing tow and yarn from hard waste	124	Parlby, S., for improvements in wheels	25
Kneller, W. G., for improvements in purifying zinc, and forming alloys thereof	187	Phillips, H., for improvements in purifying gas	39
Lambert, T., for improvements in piano-fortes	245	Poole, M., for improvements in dyeing	183
Lance, W., for an apparatus to be employed in the whale fishery, parts of which are applicable for driving machinery	162		

Page		Page
168	Robson, J. W., for improved machinery for raising and forcing liquids	
37	Rogers, G., and Morewood, E., for improvements in coating metals	
258	Roose, J., for improvements in manufacturing welded iron tubes	
96	Schottlaender, J., for improvements in depositing metals on fabrics	
237	Sheldon, W., for improvements in manufacturing buttons, japanner's ware, and articles in substitution of papier-maché	
101	Shepherd, W., for improvements in steam-engines	
328	Snell, W., for improvements in manufacturing farina	
242	Spicer, C. W., for a life-preserver or swimming-belt ...	
389	Straker, G., for improvements in windlasses	
320	Studley, F., for an improved mill	
189	Sylvester, J., for improvements in applying heat to brine and other matters	
170	Thomas, W., for an improved fastening for apparel, &c. . .	
40	Townend, E., for improvements in protecting cotton fabrics from water and mildew ...	
246	Trail, A., for improvements in strengthening sails for ships and other vessels	
337	Trent, E. W., for improvements in preparing oakum for caulking vessels	
318	Troughton, N., for improvements in dressing ores ...	
249	Turner, W. G., for improvements in manufacturing alum	
263	———, for manufacturing salts of ammonia and compounds of cyanogen from guano	
93	Walker, F. P., for improvements in manufacturing candles, candlesticks, snuffers, &c. . .	
91	Walter, J. W., for improvements in making gloves	
231	Walther, P., for improvements in steam-engines	
188	Ward, P., for improved preparations for washing and cleansing	
310	Wardroper, W., for improvements in hooks and eyes ...	
	Watson, W., for improvements in manufacturing salts of ammonia	83
	Wolcott, A. S., and Johnson, J., for improvements in photography	330
	Wood, J., for improvements in increasing the buoyancy of ships and other vessels, raising vessels or other heavy bodies, &c.	267
	Wright, J. & R., for improvements in manufacturing boots, shoes, &c.	247
	———, W., for improvements in dressing and waterproofing leather	118
	Paving, using certain compositions for, Galloway's patent	235
	Peat, improvements in preparing, Cobbold's patent	392
	Photographic pictures, mode of engraving, Claudet's patent. .	111
	———, improvements in obtaining, Wolcott and Johnson's patent	330
	———, Page's mode of coloring	216
	Piano-fortes, improvements in, Du Bochet's patent	266
	———, Lambert's patent. . .	245
	Piers, improvements in constructing, Bremner's patent	387
	———, floating, Wood's patent	267
	Piles, improvements in driving, Bremner's patent	387
	———, Nasmyth's patent	1
	Pills, improvements in manufacturing, Brockedon's patent	13
	Portmanteaus, an improved fastening for, Thomas' patent ..	170
	——— & packing-cases, improvements in making, Austin's patent	17
	Potash, improvements in manufacturing prussiate of, Newton's patent	380
	———, Turner's patent	263
	Potatoes, improvements in extracting the farina of, Snell's patent	328
	Pottery, Hardtmuth's process of glazing	213
	Power, improved apparatus for obtaining, Lance's patent ..	162
	Pring's mode of engraving upon metals by electricity	136

	Page		Page
Printing, modes of preparing Daguerreotype plates for, Claudet's patent	111	Roofing, improvements in ce- menting materials together for, Austin's patent	17
— presses, improvements in, Nichol's patent	103	—, improvements in con- structing slate, Martin's pa- tent	311
Propelling vessels, a mode of communicating motion to the screw now used for, Fairbairn's patent	166	—, improvements in pre- paring materials for, Gallo- way's patent	235
—, improve- ments in, Booth's patent....	13	Roving cans, improvements in compressing cotton in, But- terworth's patent	314
—, Davies' patent	328	Sails for ships and other vessels, improvements in manufac- turing, Trail's patent	246
Prussian blue, improvements in manufacturing, Turner's pa- tent	263	Salt, impts. in the manufac- ture of, Sylvester's patent	189
Pulleys, improvements in man- ufacturing sheaves and shells for, Lenox and Jones' patent	320	Seed, an improved mill for cob- ling, bruising, crushing, &c., Studley's patent	320
Pulse, an improved mill for cob- ling, bruising, crushing, &c., Studley's patent	id.	Sewing fabrics, an improved ap- paratus for, Bostwick's patent	304
Pumps, improvements in, Rob- son's patent	168	Shafts, improvements in man- ufacturing, Hill's patent ...	317
Purifying gas, improvements in, Phillips' patent	39	Ships and other vessels, a mode of communicating motion to the screw used for propelling, Fairbairn's patent	166
— sugar, improved ma- chinery for, Hardman's patent	153	—, applying certain compositions in the manufac- ture of, Galloway's patent ..	235
Railway axles, improvements in manufacturing, Hill's patent	317	—, improved appa- ratus for loading with coal, &c., Day's patent	20
—, lubricating and constructing the boxes for, Newton's patent	27	—, improved alloy for sheathing, Hood's patent	306
— wheels and rails, im- provements in, Charlieu's patent	241	—, improvements in increasing the buoyancy of, and raising sunken, Wood's patent	267
Railways, article on the different methods of traction or prop- ulsion in use on	358	—, improvements in manufacturing sails for, Trail's patent	246
Raising sunken vessels, improve- ments in, Bremner's patent..	387	—, improvements in preparing oakum for caul- king, Trent's patent	337
— or other heavy bodies, improvements in, Wood's patent	267	—, improvements in propelling, Booth's patent	18
— water, a wheel for, Rob- son's patent	168	—, Davies' patent	323
—, improved appa- ratus for, Hick's patent ...	225	—, improvements in raising sunken, Bremner's patent	387
Reeling fibrous substances, im- provements in, Macdonough's patent	243	—, improvements in steering and moving, Fou- lerton's patent	81
Refrigerator, an improved, for cooling liquids, Masterman's patent	33	—, improvements in windlasses for, Straker's patent	389
Registrations effected under the new Act, list of, 64, 145, 218, 292, 365, 436	436	Signals, improvements in pro- ducing light for, Hay's patent	109
Rockets, improvements in, Hale's patent	15		
Roofing, a mode of constructing fireproof, Grimsley's patent	157		

Page	Page		
Size, improvements in preparing gold, Bessemer's patent . . .	405	Tubes, impts. in manufacturing slate, Martin's patent . . .	311
Slated roofs and floors, tanks or cisterns, and pipes, improvements in constructing, Martin's patent	311	—, welded iron, Hardy's patent	301
Snuffers, improvements in, Walker's patent	93	—, Roose's patent	258
Soap, a substitute for, Ward's patent	188	Ure, Dr., article on tea by . . .	287
Soda, improvements in manufacturing prussiate of, Newton's patent	380	Valves for steam-engines, improvements in, Hick's patent	225
—, Turner's patent	263	—, Shepherd's patent	101
Spinning machinery, improvements in, Jackson's patent	7	Varnishes, improvements in preparing, for protecting metal powders and metal leaf, Bessemer's patent	405
—, Macdonough's patent	243	Ventilating apartments, improvements in, Grant's patent	397
Stamping metals, improved machinery for, Nasmyth's patent	1	Washers, improvements in the manufacture of, Lenox and Jones' patent	320
Steam-engines, improvements in, Hick's patent	225	Washing, a improved mixture for, Ward's patent	188
—, Shepherd's patent	101	— ores, improvements in, Troughton's patent	318
—, Walther's patent	231	Water, a wheel for raising, Robson's patent	168
Steering ships and other vessels, improvements in, Foulerton's patent	81	—, improved apparatus for forcing, lifting, and measuring, Hick's patent	225
Stretching fabrics, improved machinery for, Keely and Alliot's patent	373	Waterproof cement, an improved, Marshall's patent	88
Sugar contained in saccharine substances, Barreswil's method of ascertaining the quantity of crystallizable	345	Waterproofing cotton fabrics, impts. in, Townend's patent	40
—, improved machinery for manufacturing, Hardman's patent	153	— leather, improvements in, Wright's patent	118
Sweden, article on the Patent Laws of	190	Whale-fishery, improved apparatus to be used in, Lance's patent	162
Swimming-belt, an improved, Spicer's patent	242	Wheels, improvements in, Parly's patent	25
Tanks, improvements in constructing slated, Martin's patent	311	— railway, Charlieu's patent	241
Tea, article on, by Dr. Ure	287	Windlasses, improvements in, Straker's patent	389
Tiles, improvements in making, Denton's patent	393	Wood for lighting fires, improvements in preparing, Geeves' patent	248
—, Grimsley's patent	157	Yarn, producing it from "hard waste," Kitson and Garthwaite's patent	124
Tin, an improvement in the manufacture of, Longmaid's patent	22	Zinc, an improvement in the manufacture of, Longmaid's patent	22
Tubes, improved machinery for moulding clay into, Denton's patent	393	—, improvements in the preparation of, Kneller's patent	187

Nasmith's imp. in driving piles, &c.

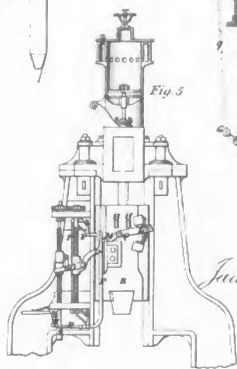
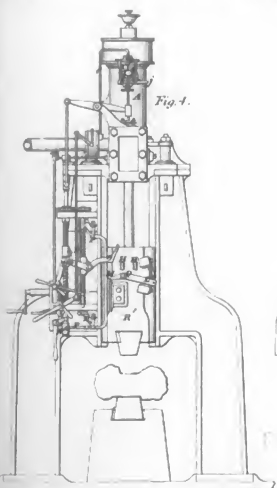
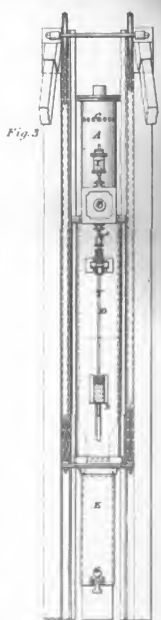
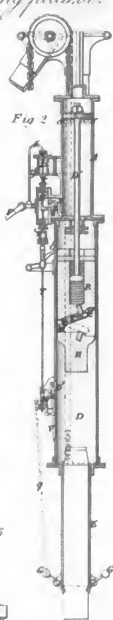
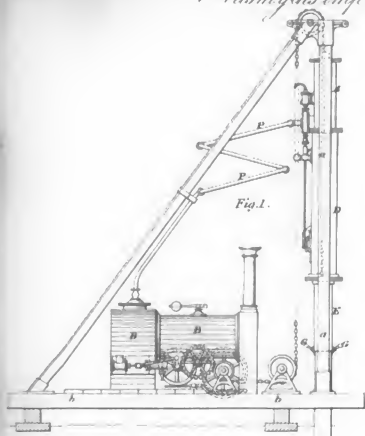

Jackson's imp. spindles of flyers.

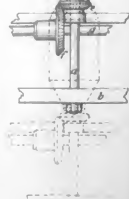
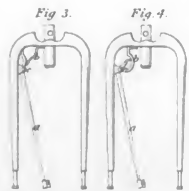
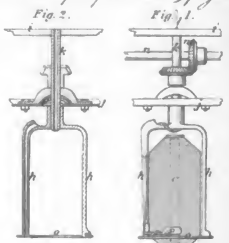

Brookedon's app. for making pills, lozenges, &c.

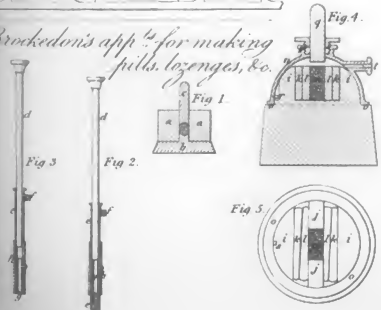

Says imp^l in loading vessels.

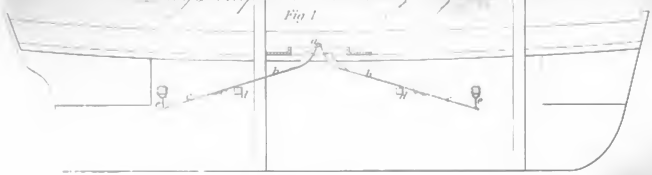

Fig 2

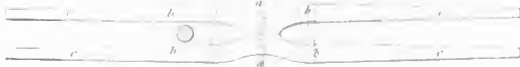

Fig 3

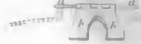
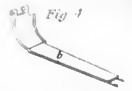

Fig 3



Fig 4



Hales imp^l rockets

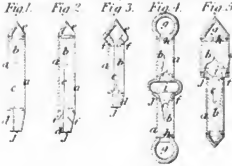

Booth's imp^l in propelling.

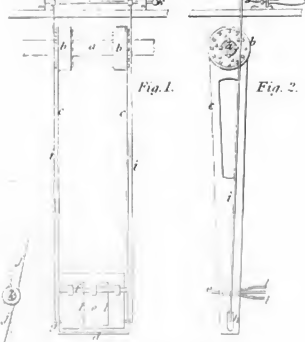

Fig 1

Fig 2

Holmes imp^l in furnaces

Fig 1

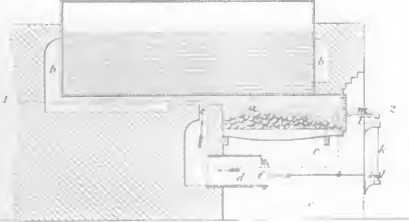

Fig 2

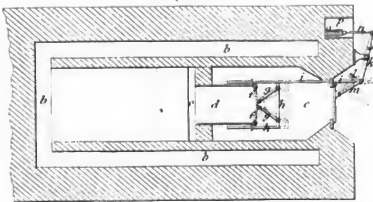

Fig 3

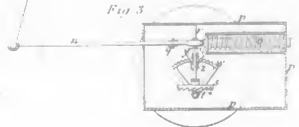
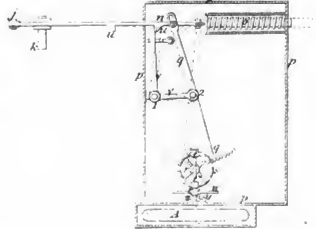
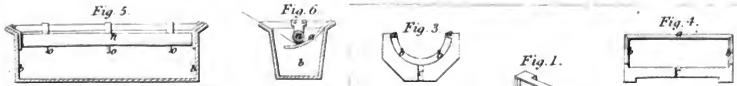
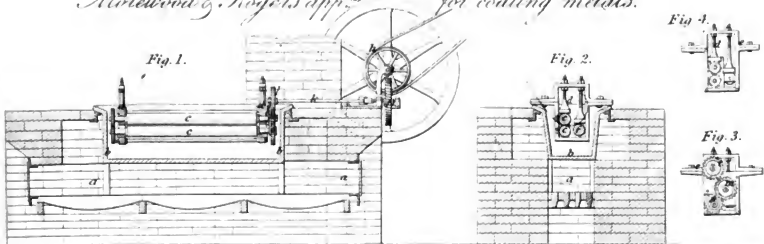

Fig 4



Morwood & Rogers's app^{ts} for coating metals.



Newton's imp^l axle boxes.

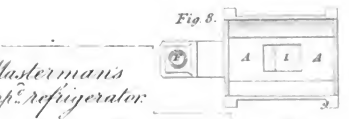
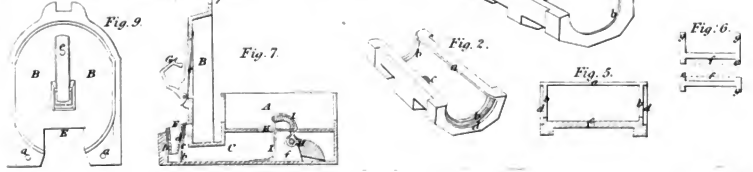

Masterman's imp^l refrigerator.

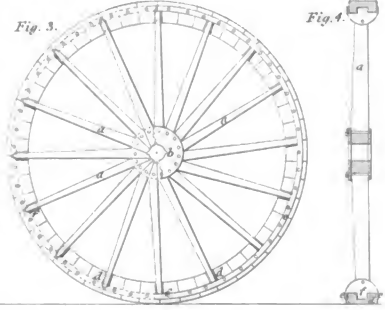
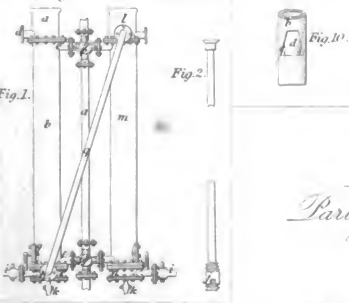

Parlby's improved wheels.

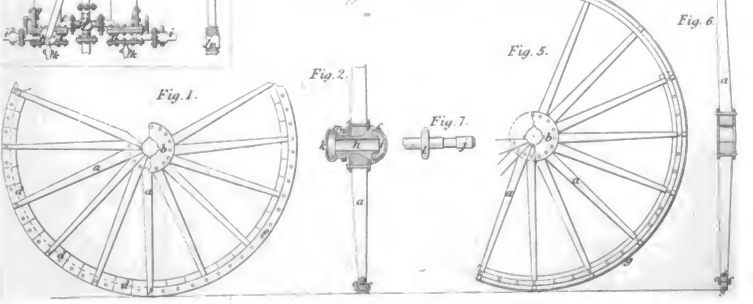

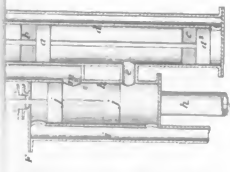
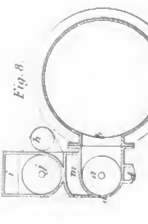
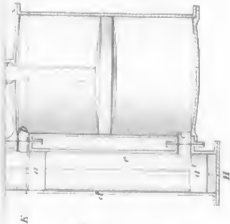
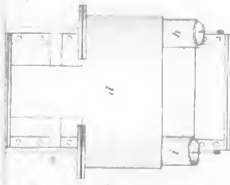
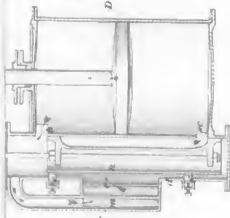
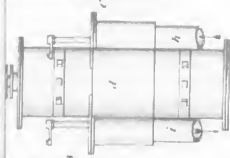
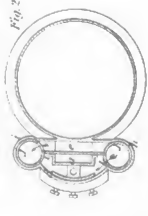
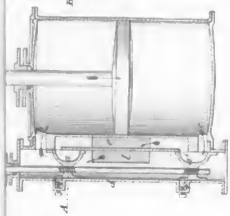

2



Foulerton's imp^{ts} in steering vessels.

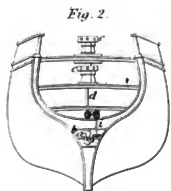

Fig. 2.

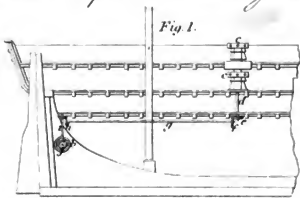

Fig. 1.

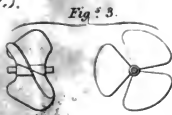

Fig. 3.

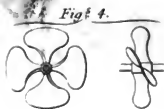

Fig. 4.

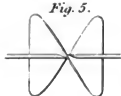

Fig. 5.

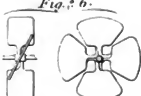

Fig. 6.

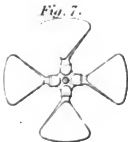

Fig. 7.

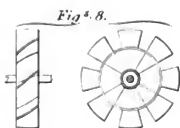

Fig. 8.

Watson's imp^o apparatus for manufact^g ammonia.

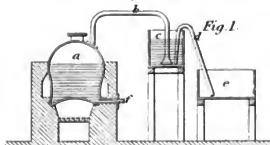

Fig. 1.

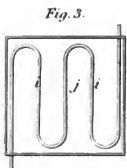

Fig. 3.

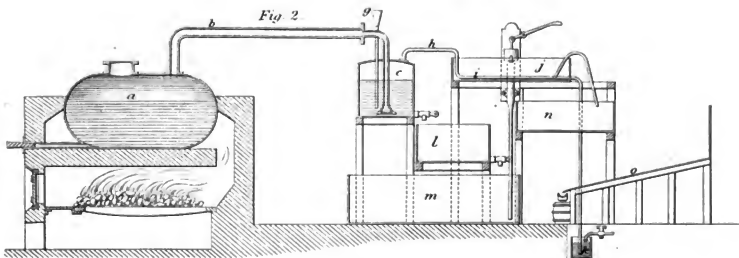

Fig. 2.

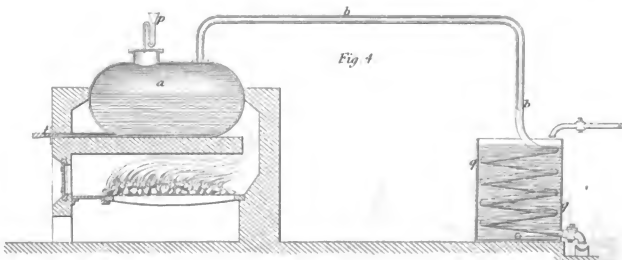
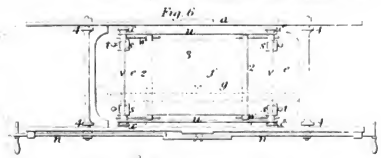
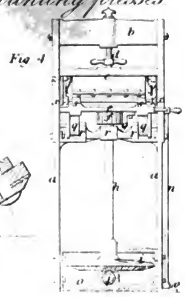
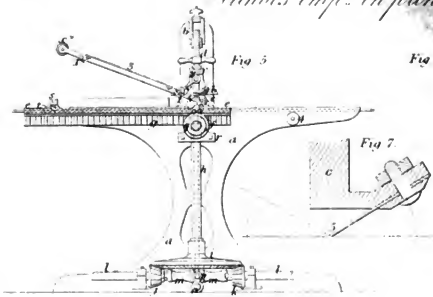
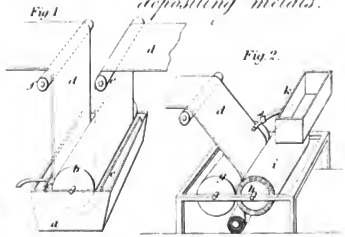
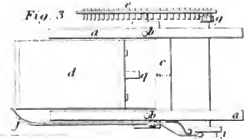
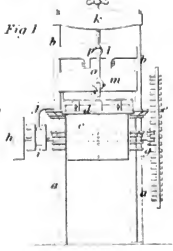
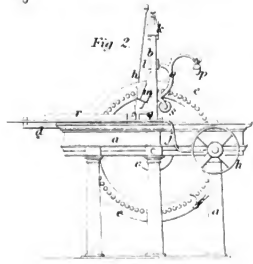
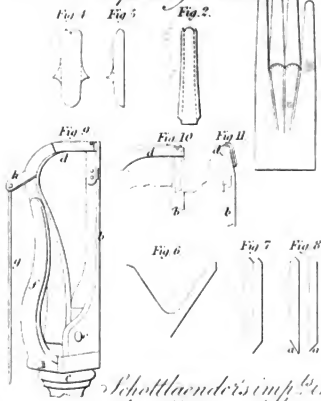

Fig. 4.

Nichols' imp^l in printing presses



Huller's imp^l in gloves



Schottlaender's imp^l in depositing metals



Hay's imp^l signals

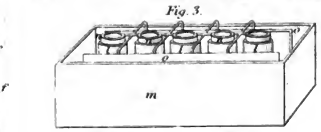

Hardmans mach^{ne} for manufacturing Sugar.

Maines imp^{ro}ve^d chain.

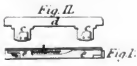
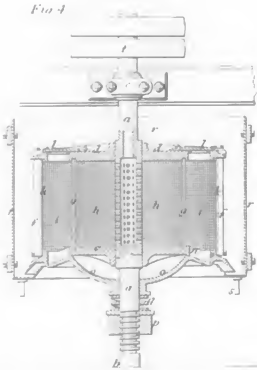
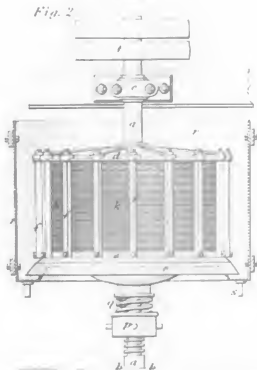
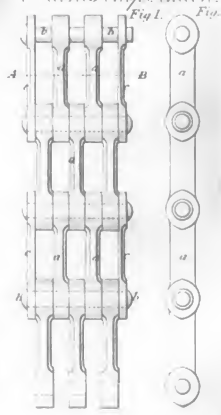
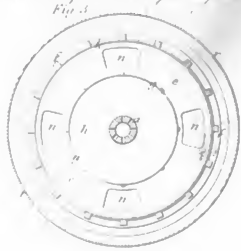
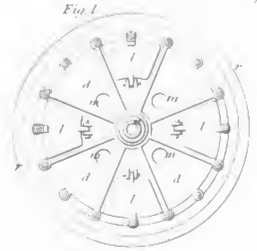

Thomas's fastenings for wearing apparel. No. 1.

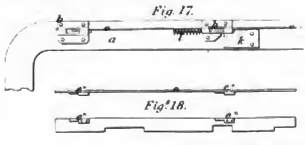
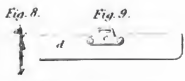
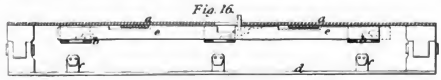
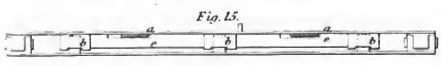
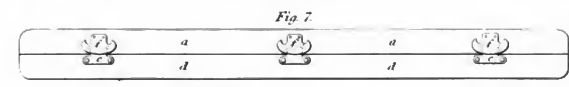
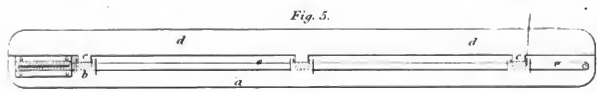
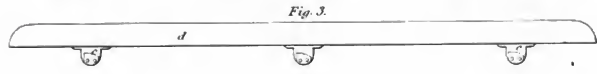
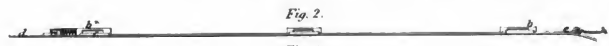
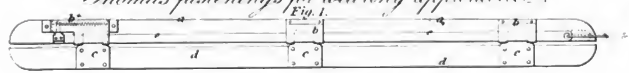

Grimsey's imp^{ts} in roofs for buildings

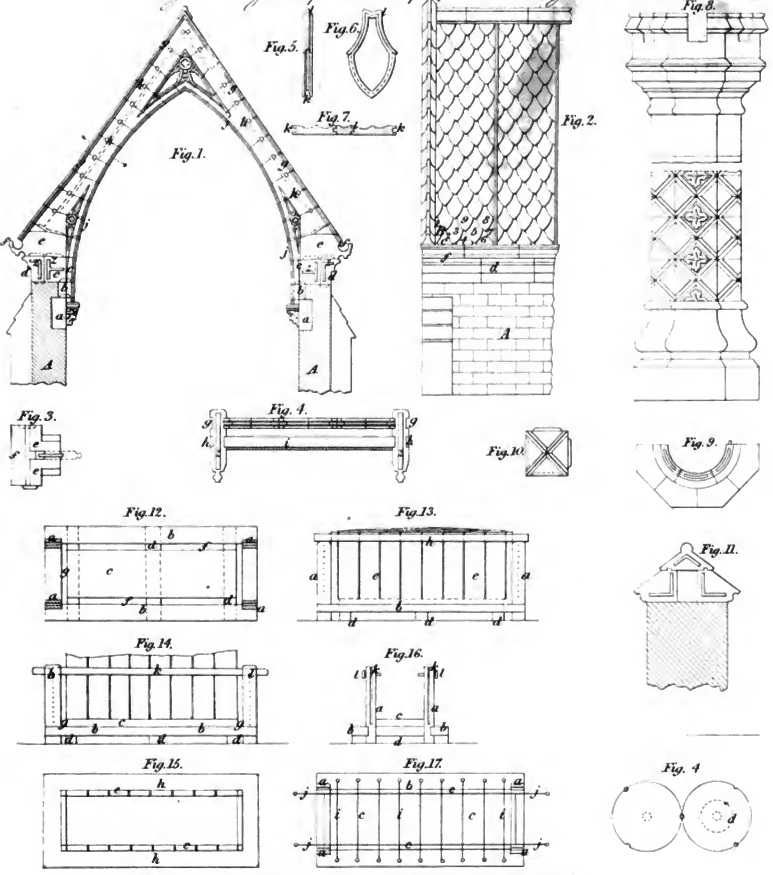

Fairbairn's imp^{ts} in propelling.

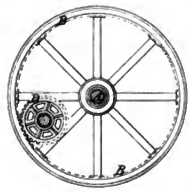

Connell's imp^d candle wicks

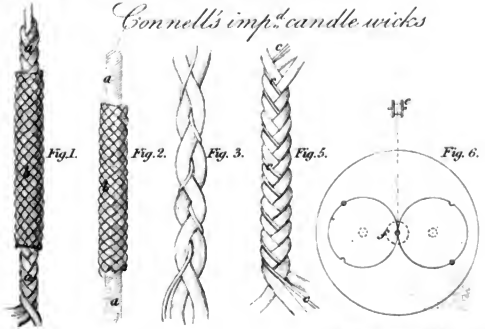

Lance's app^{ts} for whale fishery.

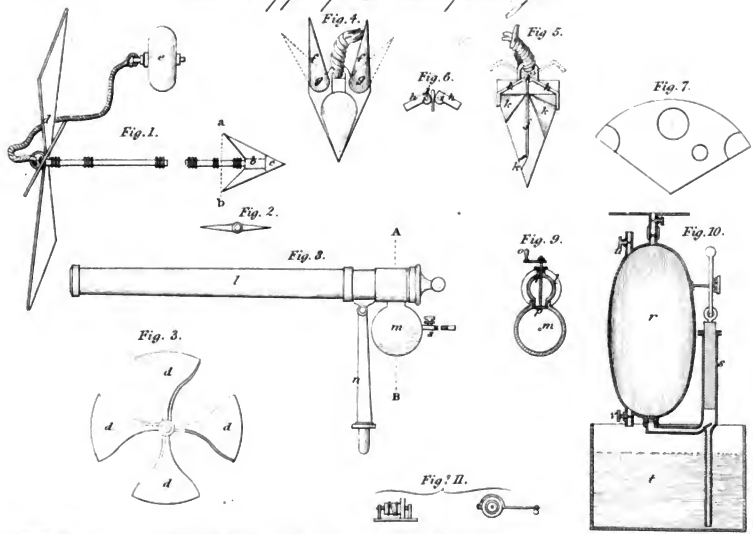

Robson's mach^y for raising liquids.

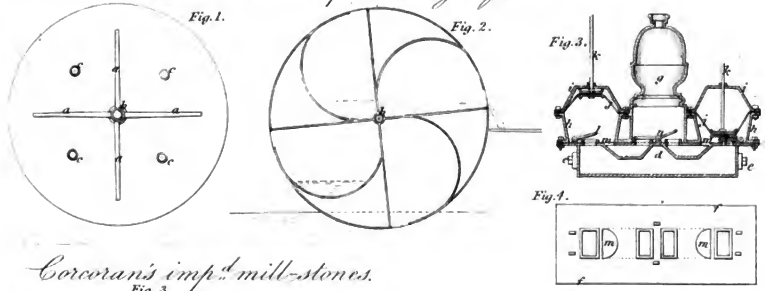

Corcoran's imp^d mill-stones.

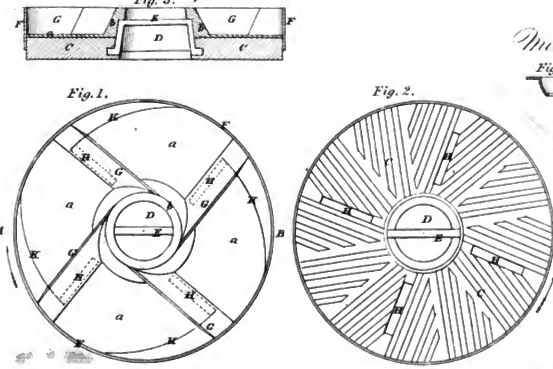

Mills fasten^g for gloves, &c.

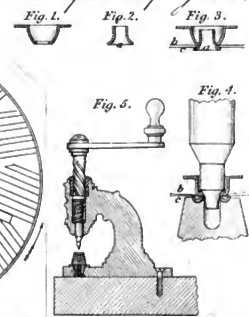

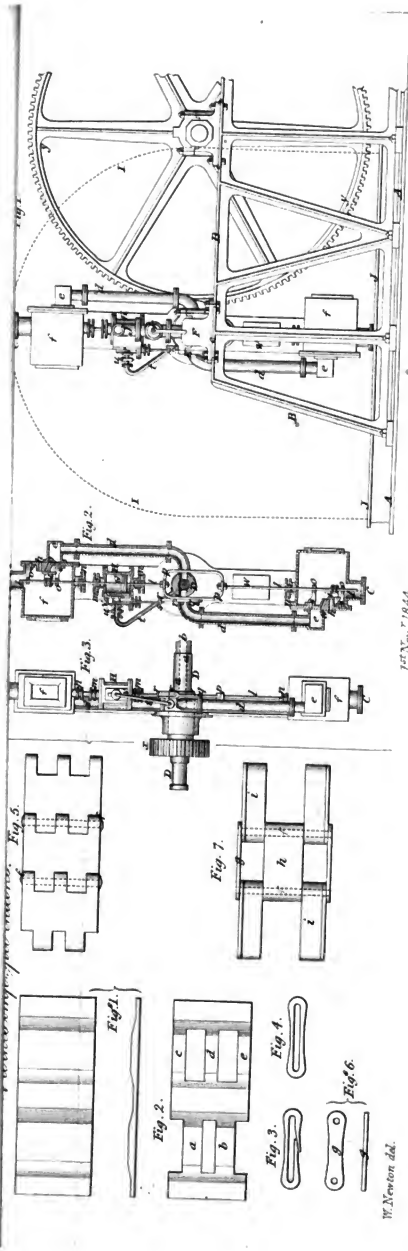

W.L. Beaver & Co.

1st Nov. 1874.

W. Newton *del.*

Woods imp^{tion} increasing the buoyancy of vessels. &c.

Fig. 1.

Fig. 2.

Fig. 3.

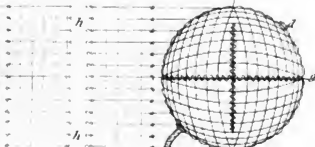
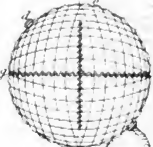
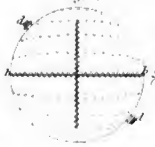

Fig. 5.

Fig. 6.

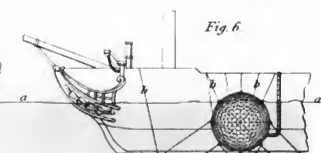
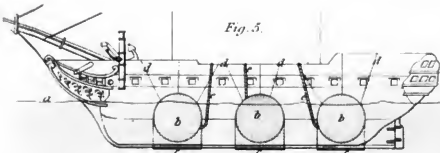

Fig. 11.

Fig. 8.

Fig. 7.

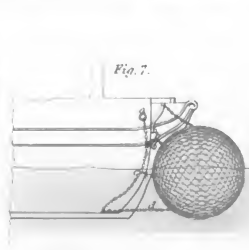
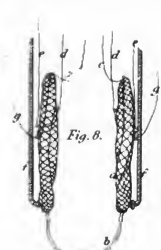
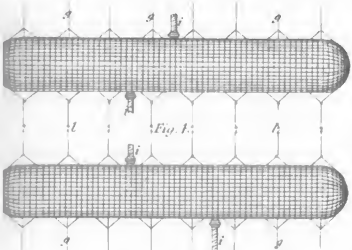

Fig. 12.

Fig. 9.

Fig. 10.

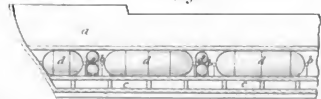

Fig. 13.

Fig. 11.

Fig. 14.

Trails imp^{ts} sails.

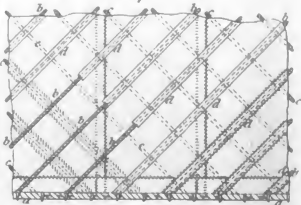
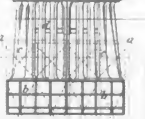
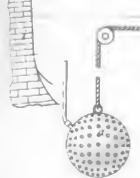
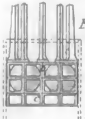
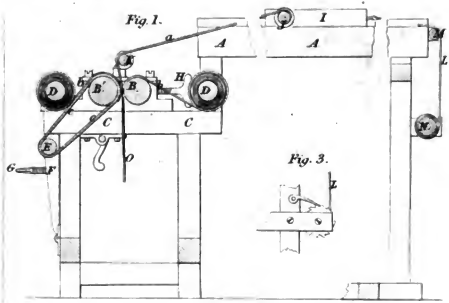
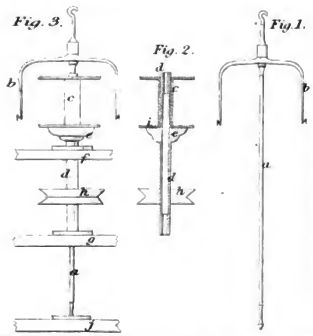

Fig. 15.

Fig. 16.





Light & Wright's imp^l in boots & shoes.

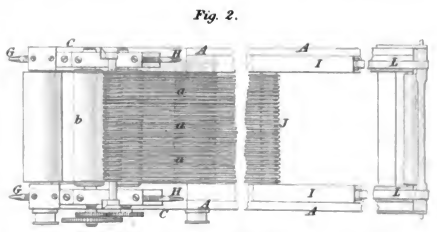
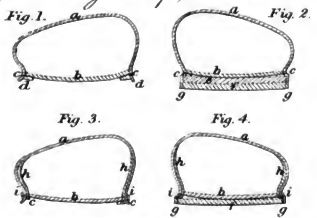

Du Rochet's imp^l in piano-fortes.

Cambert's imp^l in piano-fortes.

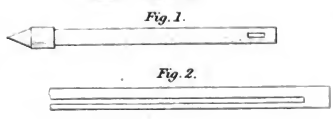
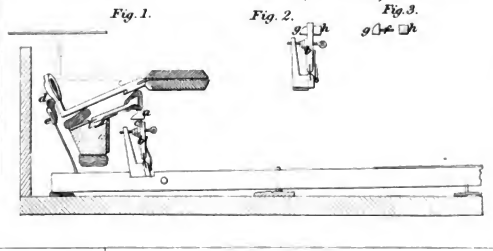
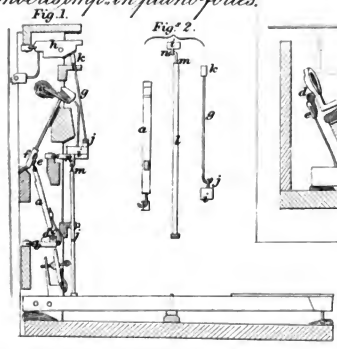

Roose's machin^y for manufact^g tubes.

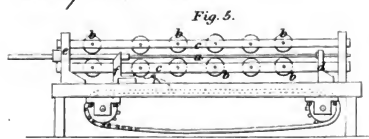

Figures.



Fig. 1.

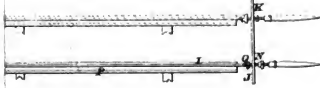

Wardrop's



Fig. 3.

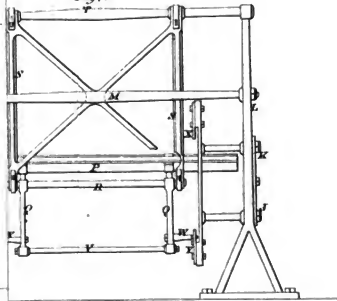

Hudley's imp. mill

Fig. 1.

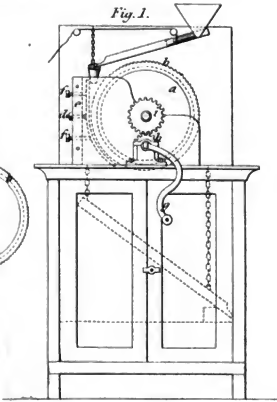
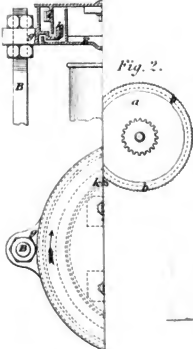

Fig. 2.



Martin's imp^{ts} in slate roofs, tanks, &c.

Fig. 1.

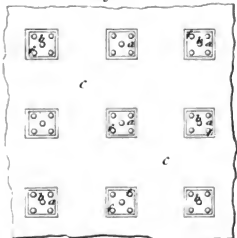

Fig. 2.

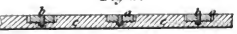

Fig. 3.

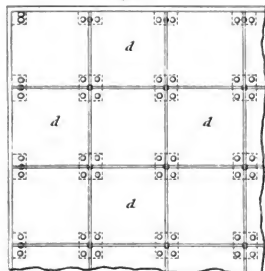

Fig. 4.



Fig. 7.

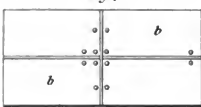

Fig. 9.

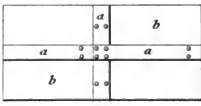

Fig. 8.



Fig. 5.

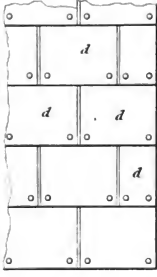

Fig. 6.



Fig. 10.

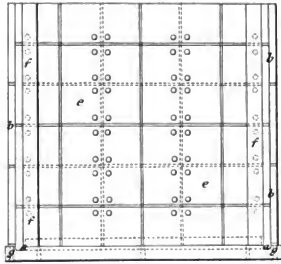

Fig. 11.

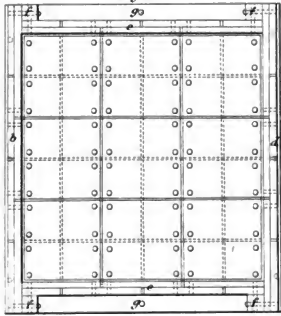

Fig. 12.



Fig. 13.



Fig. 15.

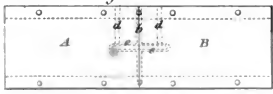

Fig. 14.



Hill's imp^{ts} in axles, shafts, &c.

Fig. 1.



Fig. 2.



Fig. 3.



Troughton's imp^{ts} in washing ores.

Fig. 1.

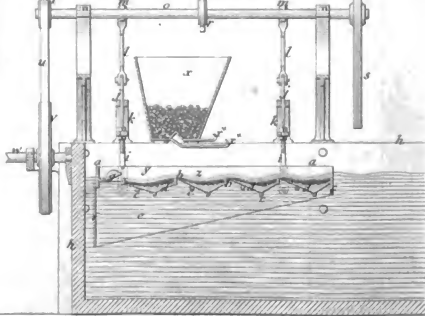
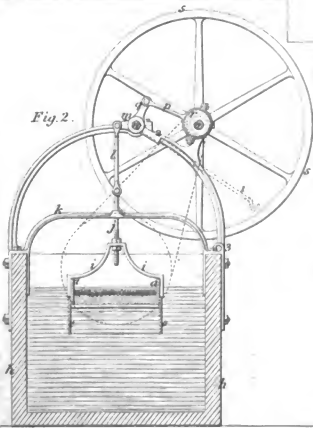

Fig. 2.



machine & process used in photography.

Fig. 4.

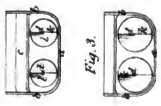

Fig. 1.



Fig. 3.



Fig. 2.

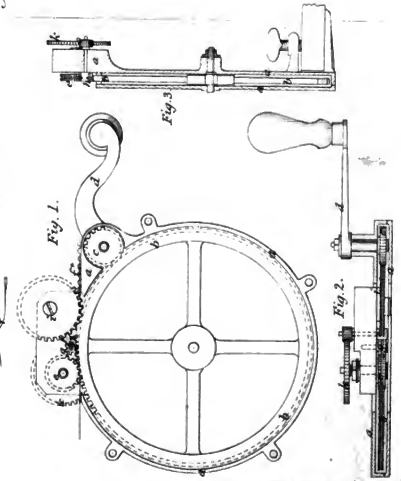

Fig. 5.



stewie's mack for sewing

Fig. 4.



Machin's app. for dress' garments.

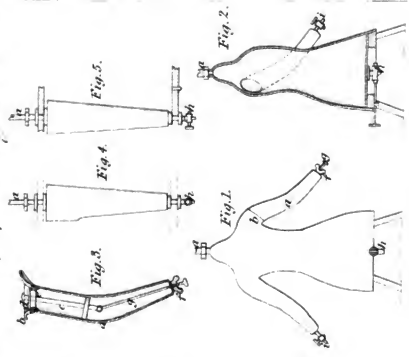

Fig. 1.

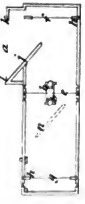

Fig. 2.



Fig. 3.

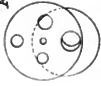

Fig. 4.



Fig. 1.

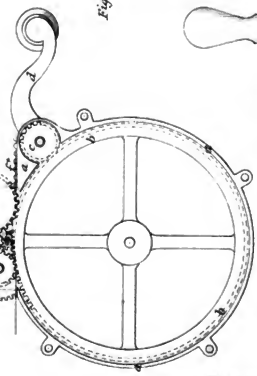

Fig. 3.

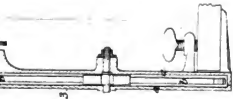

Fig. 3.

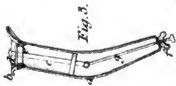

Fig. 4.



Fig. 5.



Fig. 1.

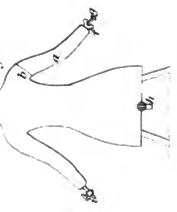

Fig. 2.

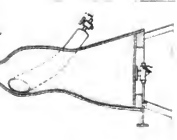

Fig. 6.



Fig. 5.

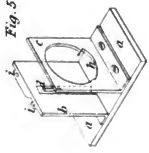
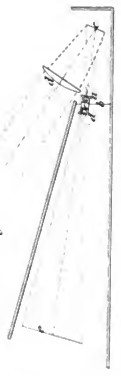
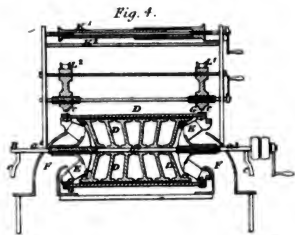
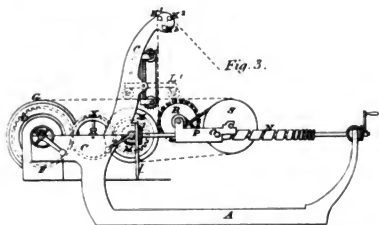
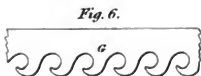
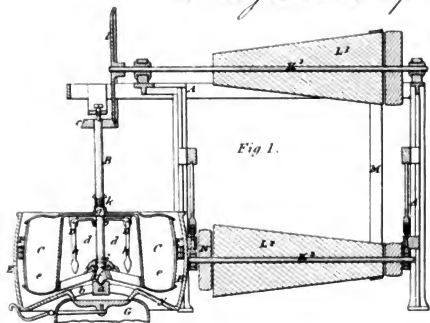

Fig. 7.



Keoley & Alliot's imp^d in drying cloth &c.



Straker's imp^d windlass

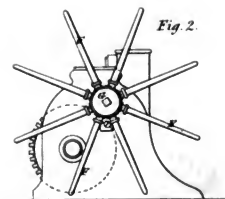
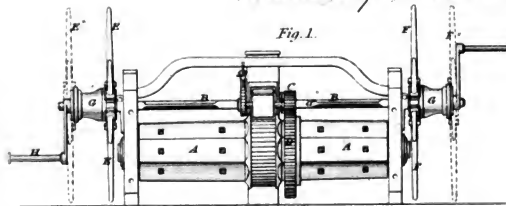

Hazards imp^d shower bath

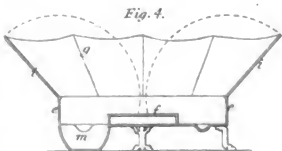
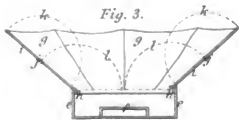
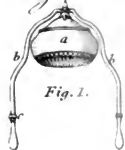

Mallett & Bridgman's mach^y for treating fatty matter

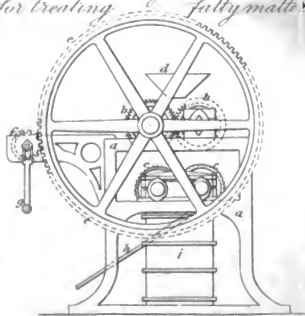

Newton's imp^{ts} in manufact^y cyanogen.

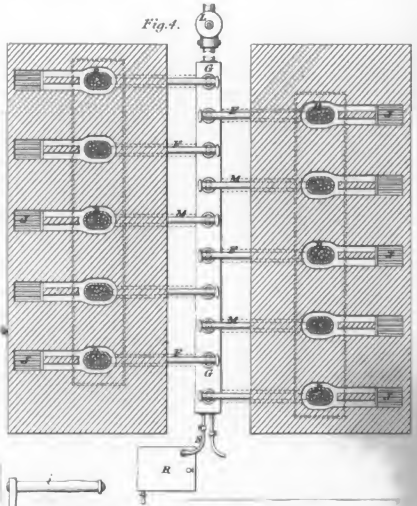
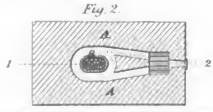
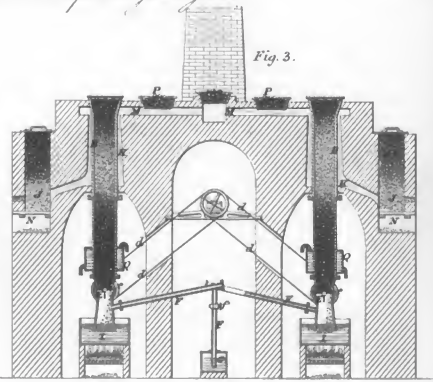
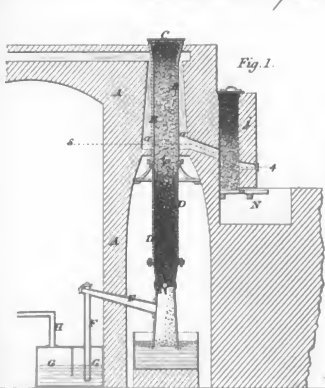

Cobbold's imp^{ts} in preparing peat.

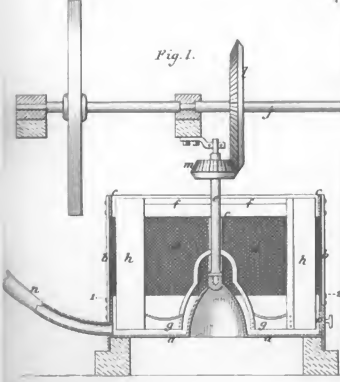
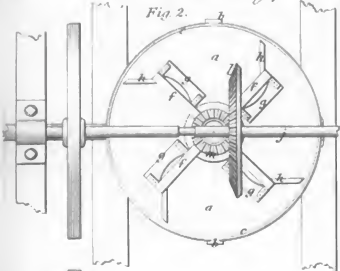

Denton's mach^y for producing drain tiles.

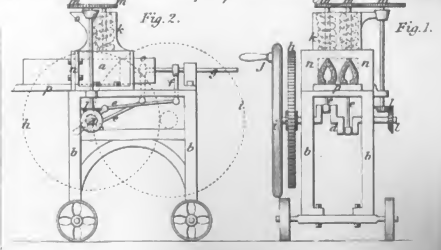

Grant's imp^{ts} in ventilating gas burners.

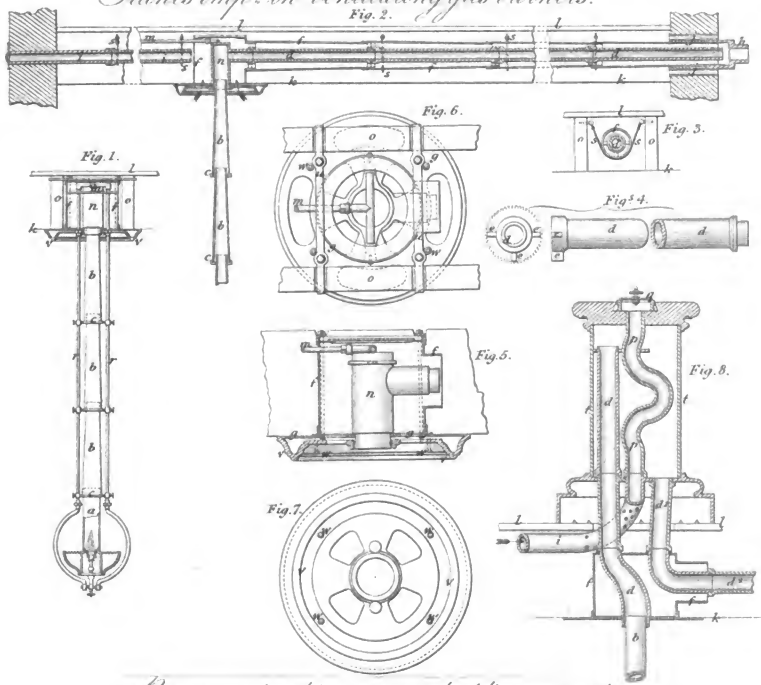

Bremner's imp^{ts} in construct^g buildings in water.

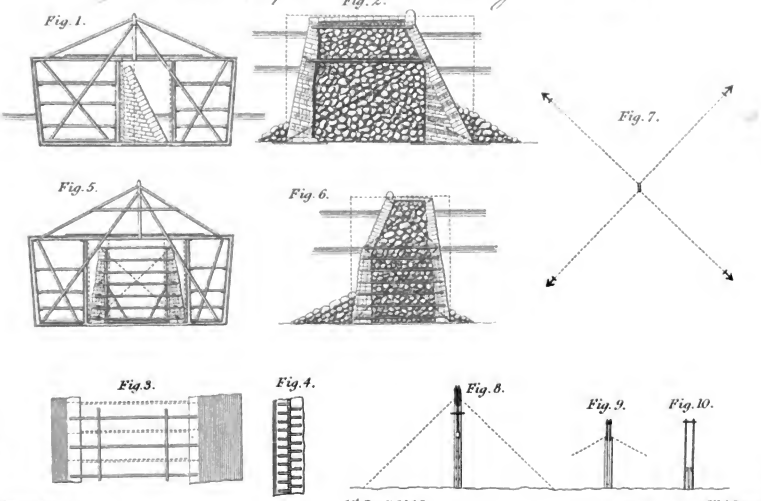

UNIVERSITY OF MICHIGAN



3 9015 06355 9853

A 514298

